

**SPACE-TIME TURBO CODED
MODULATION FOR WIRELESS
COMMUNICATION SYSTEMS**

**DJORDJE
TUJKOVIC**

Department of Electrical and
Information Engineering,
University of Oulu

OULU 2003



DJORDJE TUJKOVIC

**SPACE-TIME TURBO CODED
MODULATION FOR WIRELESS
COMMUNICATION SYSTEMS**

Academic Dissertation to be presented with the assent of the Faculty of Technology, University of Oulu, for public discussion in Raahensali (Auditorium L10), Linnanmaa, on April 23th, 2003, at 12 noon.

OULUN YLIOPISTO, OULU 2003

Copyright © 2003
University of Oulu, 2003

Supervised by
Professor Markku Juntti

Reviewed by
Professor Helmut Bölcskei
Professor Arne Svensson

ISBN 951-42-6997-7 (URL: <http://herkules.oulu.fi/isbn9514269977/>)

ALSO AVAILABLE IN PRINTED FORMAT

Acta Univ. Oul. C 184, 2003

ISBN 951-42-6996-9

ISSN 0355-3213 (URL: <http://herkules.oulu.fi/issn03553213/>)

OULU UNIVERSITY PRESS
OULU 2003

Tujkovic, Djordje, Space-time turbo coded modulation for wireless communication systems

Department of Electrical and Information Engineering, University of Oulu, P.O.Box 4500, FIN-90014 University of Oulu, Finland
Oulu, Finland
2003

Abstract

High computational complexity constrains truly exhaustive computer searches for good space-time (ST) coded modulations mostly to low constraint length space-time trellis codes (STTrCs). Such codes are primarily devised to achieve maximum transmit diversity gain. Due to their low memory order, optimization based on the design criterion of secondary importance typically results in rather modest coding gains. As another disadvantage of limited freedom, the different low memory order STTrCs are almost exclusively constructed for either slow or fast fading channels. Therefore in practical applications characterized by extremely variable Doppler frequencies, the codes typically fail to demonstrate desired robustness. On the other hand, the main drawback of eventually increased constraint lengths is the prohibitively large decoding complexity, which may increase exponentially if optimal maximum-likelihood decoding (MLD) is applied at the receiver. Therefore, robust ST coded modulation schemes with large equivalent memory orders structured as to allow sub-optimal, low complexity, iterative decoding are needed.

To address the aforementioned issues, this thesis proposes parallel concatenated space-time turbo coded modulation (STTuCM). It is among the earliest multiple-input multiple-output (MIMO) coded modulation designs built on the intersection of ST coding and turbo coding. The systematic procedure for building an equivalent recursive STTrC (Rec-STTrC) based on the trellis diagram of an arbitrary non-recursive STTrC is first introduced. The parallel concatenation of punctured constituent Rec-STTrCs designed upon the non-recursive Tarokh et al. STTrCs (Tarokh-STTrCs) is evaluated under different narrow-band frequency flat block fading channels. Combined with novel transceiver designs, the applications for future wide-band code division multiple access (WCDMA) and orthogonal frequency division multiplexing (OFDM) based broadband radio communication systems are considered. The distance spectrum (DS) interpretation of the STTuCM and union bound (UB) performance analysis over slow and fast fading channels reveal the importance of multiplicities in the ST coding design. The modified design criteria for space-time codes (STCs) are introduced that capture the joint effects of error coefficients and multiplicities in the two dimensional DS of a code. Applied to STTuCM, such DS optimization resulted in a new set of constituent codes (CCs) for improved and robust performance over both slow and fast fading channels. A recursive systematic form with a primitive equivalent feedback polynomial is assumed for CCs to assure good convergence in iterative decoding. To justify such assumptions, the iterative decoding convergence analysis based on the Gaussian approximation of the extrinsic information is performed. The DS interpretation, introduced with respect to an arbitrary defined effective Hamming distance (EHD) and effective product distance (EPD), is applicable to the general class of geometrically non-uniform (GNU) CCs. With no constraints on the implemented information interleaving, the STTuCM constructed from newly designed CCs achieves full spatial diversity over quasi-static fading channels, the condition commonly identified as the most restrictive for robust performance over a variety of Doppler spreads. Finally, the impact of bit-wise and symbol-wise information interleaving on the performance of STTuCM is studied.

Keywords: code optimization, convergence analysis, distance spectrum, OFDM, space-time coding, turbo coding, union bound, WCDMA

To my family

Preface

The research behind this thesis was carried out at the Telecommunication Laboratory (TIL) and the Centre for Wireless Communications (CWC), University of Oulu, Finland. I wish to express my appreciation to Dr. Jaakko Talvitie, the former head of the CWC, for inviting me to join his Laboratory. I arrived to Oulu in January 1999 to participate in a six month project on "combined turbo decoding and interference suppression" and to disappear to Nokia afterwards. I am grateful to my advisor, Professor Matti Latva-aho, who talked me into Doctoral studies arguing that it takes nothing but the few years of extraordinary hard work. His moral support and guidance throughout the course of my studies were invaluable. Professor Matti Latva-aho, as the present head of CWC, and Professor Pentti Leppänen, the head of TIL, are acknowledged for creating a versatile research environment where I was exposed to different aspects of wireless communications and broadened my knowledge above the essence of my research area.

I was fortunate to have Professor Markku Juntti as my supervisor. His pursuit for the highest standards in research was the great source of my inspiration. I wish to thank him for his guidance, encouragement and unreserved help, especially during the last years of my study. I am grateful to the reviewers of the thesis, Professor Helmut Bölcskei from the Swiss Federal Institute of Technology, Zurich, Switzerland, and Professor Arne Svensson from Chalmers University of Technology, Göteborg, Sweden. I am also grateful to Dr. Ian Oppermann and Zach Shelby for commenting and proofreading the manuscript.

My numerous colleagues from the CWC and TIL are acknowledged for creating a friendly working atmosphere. I had the great pleasure to advise the Master's thesis of Esa Kunnari, Raffaello Tesi, Emiliano Sottani and Mikko Vehkaperä who have influenced the contents of my thesis either directly or indirectly. My special thanks are due to Esa Kunnari for being a joyful and inspiring office mate during all these years. My special thanks extend to Kimmo Kansanen and Kari Hooli, my good friends and immediate "co-sufferers" during the course of study. I have fond memories of our lively discussions and the good times we shared. The administrative personnel, especially Antero Kangas, Elina Kukkonen, Mikko Ojala, Jari Sillanpää, and Timo Äikäs, are gratefully acknowledged for being immensely

efficient in getting things done. Thanks are also due to Marja Leppäharju, the secretary of the Graduate School of Electronics, Telecommunications and Automation (GETA). Also, I wish to thank Nedeljko Cvejic for being a sincere friend, especially when I most needed one.

The generous financial support provided by Nokia Networks, Nokia Mobile Phones, Elektrobit, Finnish Defense Forces, the National Technology Agency of Finland (Tekes), GETA, the Nokia Foundation, and the Elisa Communications Foundation is gratefully acknowledged.

I do not find words to express my gratitude to my loving parents, Margita and Miodrag, and my brother Ivan for everything they have done for me. My devotion to work hard and strength to continue whenever the going gets tough in life, I grasp from the immense love and support that these Engineers invested in me.

My warmest appreciations are due my loving wife Ilijana for being a wonderful source of joy, love and encouragement in my life. She always knew much better than me why I must not quit with this thesis. I admire her ability to bear with such a boring student. I promise to spend more time with you from now on!

Oulu, March 2003

Djordje Tujkovic

List of original papers

This thesis is based on the twelve original papers (Appendices I – XII), which are referred to by Roman numerals in the text. All the listed papers have been conceived and written by the author. In the case of Papers VII and VIII, the author advised the Master's thesis research during which the simulations were partly carried out by the Master's student. All other analysis and simulation results presented in publications, submitted material or this thesis have been produced solely by the author.

- I Tujkovic D (2000) Space-time turbo coded modulation. In Proc. Finnish Wireless Communications Workshop (FWCW'00), Oulu, Finland, May 29-30, p. 85–89.
- II Tujkovic D (2000) Recursive space-time trellis codes for turbo coded modulation. In Proc. IEEE Global Communications Conference (GLOBECOM'00), San Francisco, USA, November 27 – December 1, vol. 2, p. 1010–1015.
- III Tujkovic D (2001) High bandwidth efficiency space-time turbo coded modulation. In Proc. IEEE International Conference on Communications (ICC'01), Helsinki, Finland, June 11–15, vol. 4, p. 1104–1109.
- IV Tujkovic D, Juntti M, Latva-aho M (2001) Space-frequency turbo coded OFDM. In Proc. IEEE Global Communications Conference (GLOBECOM'01), San Antonio, USA, November, vol. 2, p. 876–880.
- V Tujkovic D, Juntti M, Latva-aho M (2001) Space-frequency-time turbo coded modulation. IEEE Communications Letters, vol. 5, no. 12, p. 480–482.
- VI Tujkovic D, Juntti M, Latva-aho M (2002) Space-time turbo coded modulation: Design and Applications. EURASIP Journal on Applied Signal Processing, Special Issue on Space-Time Coding and its Applications, Part-I, vol. 2002, no. 3, p. 236–248.
- VII Tujkovic D, Sottani E (2002) Combined array processing and space-time turbo coded modulation for WCDMA downlink over frequency-selective Rayleigh fading channels. In Proc. IEEE International Symposium on Spread Spectrum Techniques and Applications (ISSSTA'02), Prague, Czech Republic, September 2–5, vol. 2, p. 313–317.

- VIII Tujkovic D, Sottani E (2003) Orthogonalized spatial multiplexing for MIMO WCDMA downlink over frequency-selective Rayleigh fading channels. Submitted to the Sixth Baiona Workshop on Signal Processing in Communications, Baiona, Spain, September 8-10.¹
- IX Tujkovic D, Juntti M, Latva-aho M (2002) Distance spectrum interpretation and performance analysis of space-time turbo coded modulation on quasi-static fading channels. In Proc. Conference on Information Sciences and Systems (CISS'02), Princeton, USA, March 20–22.
- X Tujkovic D, Juntti M, Latva-aho M (2002) Union bound for space-time turbo coded modulation over fast fading channels. In Proc. IEEE International Symposium on Personal Indoor and Mobile Radio Communications (PIMRC'02), Lisbon, Portugal, September, vol. 1, p. 79–84.
- XI Tujkovic D (2003) Constituent code optimization for space-time turbo coded modulation based on distance spectrum and iterative decoding convergence. In Proc. IEEE Information Theory Workshop (ITW'03), Paris, France, March 31 – April 4, to appear.
- XII Tujkovic D (2003) Performance analysis and constituent code design for space-time turbo coded modulation over fading channels. Submitted to IEEE Transactions on Information Theory, March.²

¹Paper was accepted in a similar form and listed in the conference technical program of the Asilomar Conference 2002, Pac. Grove, USA, November 2002. Since authors were not able attend the conference, paper did not appeared in the conference proceedings.

²Related results in Proc. IEEE International Symposium on Information Theory (ISIT'03), Yokohama, Japan, June 29 – July 4, to appear.

Contents

Abstract	
Preface	
List of original papers	
Contents	
1 Introduction	13
1.1 Space-time in radio communications	14
1.1.1 Diversity	15
1.1.2 Spatial filtering	16
1.2 MIMO channel capacity	17
1.2.1 Capacity expressions	17
1.2.2 Spatial channel models	21
1.3 Aim and outline of the thesis	23
2 Literature survey	25
2.1 Turbo coding	25
2.1.1 Design and principles	26
2.1.2 Turbo coded modulation	28
2.2 Space-time coding	30
2.2.1 MIMO channel reliability	31
2.2.2 Space-time coded modulation	34
2.2.3 Space-time block codes	37
2.2.4 Layered space-time coding architectures	38
3 Scope of the thesis	41
3.1 Problem formulation	41
3.2 Contribution of the thesis	42
3.3 Closely related parallel work	43
4 Summary of the original publications	47
4.1 System model of space-time turbo coded modulation	47
4.1.1 Encoder	48
4.1.2 Information interleaving	48
4.1.3 Decoder	50
4.2 Application scenarios	50

4.2.1	Narrowband frequency flat fading channels	51
4.2.2	Broadband OFDM based wireless local area networks	52
4.2.3	Wideband code-division multiple-access systems	54
4.3	Performance analysis	56
4.3.1	Distance spectrum interpretation	56
4.3.2	Union bound over slow and fast fading channels	58
4.3.3	Iterative decoding convergence analysis	59
4.4	Constituent code design and optimization	61
4.4.1	Design criteria	61
4.4.2	Subset of constituent codes for optimization	62
4.4.3	Distance spectrum optimization	64
4.4.4	Comparison between bit and symbol interleaving	66
5	Conclusions	69
5.1	Summary and discussion	69
5.2	Future research directions	71
	References	73
	List of symbols and abbreviations	
	Errata	
	Original papers	

1 Introduction

“A cheap and simple device, which might be carried in one’s pocket may then be set up anywhere on sea or land, and it will record the world’s news or such special messages as may be intended for it. Thus the earth will be converted into a huge brain . . . the system will have a virtually infinite working capacity and immensely facilitate and cheapen the transmission of intelligence.”

— Nikola Tesla, 1904.

The radio age began just over 100 years ago with the invention of Nikola Tesla’s coils and is now set for continued rapid growth as we witness the dawn of a new millennium. The ambition of wireless personal communications is to allow users to communicate reliably and cost effectively in any form, at any time regardless of their location or mobility. A wireless system designer is faced with a number of challenges in achieving such goals. The hostile radio propagation environment and impeded in-building penetration are the major obstacles. Other challenges include the limited battery storage of portable units and the scarce and expensive spectrum whose aggressive deployment causes inevitable co-channel interference (CCI). Cellular operators’ appetite for increased revenue has pushed demands for greater coverage, increased system capacity, less infrastructure and lower operating costs. A number of different technologies have been exploited in existing systems to meet such diverse requirements. These include advanced multiple-access techniques such as slow frequency-hopped time-division multiple-access (TDMA), code-division multiple access (CDMA), and different duplexing schemes such as time-division duplex (TDD) and frequency-division duplex (FDD). Sophisticated signal processing techniques like source coding, bandwidth efficient signalling methods including error-control coding and modulation, diversity methods, adaptive equalization etc., have been vital for the success of existing cellular systems.

Successful business models have always relied on developing the services that satisfy early identified, fundamental user requirements. Although being a long

away from the envisioned true transfer of intelligence, the expanded range of different interactive services like e-mail, multimedia messaging, Internet browsing, video conferencing, audio and video streaming, e-commerce and wireless positioning are identified as key requirements for future wireless systems. Such services face a limited future unless reliable and fast transmission of information over the air with data rates of several hundreds of Megabits per second (Mbps) is enabled. The lack of availability for spectral expansion that is traditionally needed for higher data rates and wireless system capacities motivated vast interest in spectral efficiency where the spatial domain seems to remain the final frontier for improvement. Inspiring the recent renaissance in spatial and temporal signal processing, the latest results in information theory supported by extensive field measurement campaigns have demonstrated the potentially large capacity increase for certain multiple-input multiple-output (MIMO) wireless channels. As an eventual evolution of space-time (ST) processing techniques, ST coding is a signalling method intended to approach the MIMO channel capacity limits by simultaneously encorrelating signals across spatial and temporal domains. The topic of this thesis is the design and analysis of advanced ST signalling methods and transceiver algorithms for MIMO wireless channels with applications for evolving broadband radio communication standards.

1.1 Space-time in radio communications

Ever since the dawn of information theory [1], capacity has been a principal metric to evaluate a communication system. Several definitions of capacity exist. The *link*, *user*, or *channel* capacity is referred to as the highest data rate at which reliable communication is possible between a transmitter and a receiver. At the same time, *system* capacity is commonly used to indicate the total system throughput, i.e., the sum of all user data rates, within a cell or a sector. The system capacity can also be expressed in terms of *area* capacity simply by normalizing by the cell size. Furthermore, *spectral efficiency*, defined as the capacity per unit bandwidth, has become another key metric by which communication systems are measured.

The propagation of radio signals through a physical channel is subjected to free-space propagation loss (path loss) and fluctuations in signal level called fading [2, 3, 4]. Fading includes long-term and short-term variations. Long-term variations are caused by shadowing effects due to energy absorbing objects along the propagation path. The short-term varying fading corresponds to rapid fluctuations of the received signal caused by relative movements of a transmitter or a receiver with respect to surrounding scatterers. Propagating through the radio channel, a signal arrives at the destination along a number of different paths, referred to as multipaths arising from scattering, reflection, and diffraction of the radiated energy against the propagation environment. The multipath propagation results in spreading of the signal in three different dimensions — delay (or time) spread, Doppler (or frequency) spread, and angular spread. Spread in the delay domain appears in frequency selective channels and causes inter-symbol interference (ISI) at a receiver. A frequency selective channel can be characterized by the *coherence bandwidth*, the

maximum frequency separation for which the frequency-domain channel responses at two separate frequencies remain strongly correlated. Relative motion between the transmitter and receiver causes the Doppler spread, i.e., a pure tone is spread over a finite frequency band. Approximately inversely proportional to the Doppler spread, the *coherence time* represents a time separation for which the channel impulse responses at two time instances remain strongly correlated. Angular spread is caused by a spatially-selective channel and refers to the distribution of angle-of-arrival (AOA) of the multipaths at the receiver, and the angle-of-departure (AOD) at the transmitter. A spatially-selective channel is characterized by the *coherence distance*. Inversely proportional to angular spread and normalized by the carrier wavelength it determines the maximum spatial separation for which the channel responses at two antennas remain strongly correlated. For more profound insight on the radio propagation aspects and statistical modelling of multidimensional fading channels the reader is referred to [2, 3, 4, 5, 6, 7, 8, 9, 10, 11, 12, 13, 14, 15, 16, 17, 18].

1.1.1 Diversity

Diversity in general refers to sending multiple copies of the same transmitted signal through possibly independent fading channels increasing the probability that at least one signal will arrive at the receiver without severe deterioration. Different diversity methods include temporal, frequency, and antenna diversity.

Temporal diversity is typically obtained by the combination of error-control coding (also known as channel coding) and channel interleaving. Coding adds redundancy to information data and introduces correlation between symbols in the output code-word. If the transmission time interval between two consecutive symbols in the code-word after interleaving becomes larger than the coherence time of the channel, the transmitted symbols will fade independently, and combined with decoding, information can be reliably recovered. Frequency diversity can be exploited if the signal bandwidth spans multiple coherence bandwidths of the channel. In single-carrier (SC) systems, frequency diversity may be achieved in a number of different ways. Slow frequency-hopping is proposed for the Global system for mobile communications (GSM). The *Viterbi* and adaptive equalizer achieve the same effect for general TDMA and CDMA type systems while a RAKE multipath combiner is commonly used in CDMA type systems. In systems with multi-carrier (MC) modulation such as orthogonal frequency division multiplexing (OFDM) and MC-CDMA, the combination of channel coding and interleaving across independently faded sub-carriers achieves the same effect as temporal diversity.

Antenna diversity includes spatial, polarization, and angular diversity. An *antenna array* is defined as a group of spatially distributed antennas. For spatial diversity, antennas in the array need to be separated by more than the coherence distance to obtain a low fading correlation (correlation factor 0.7 or lower). With the mobile station (MS) generally placed low below rooftops and surrounded by scatterers, the angular spread is typically uniformly distributed and a quarter-wavelength spacing of antennas is sufficient. This also holds for base stations (BSs) in indoor

and microcell environments where antennas are usually mounted at the same height as the surrounding objects. For outdoor and macrocell environments, BSs are typically deployed in isolated spots high above rooftops. Therefore, the angular spread may be only a few degrees in rural areas and somewhat higher in urban areas. A horizontal separation of 10–20 wavelengths between antenna elements is commonly needed to secure low spatial correlation. Due to the different size, weight, and power constraint, spatial diversity is more suitable for BSs than for an MS and as such have been commercially used for many years in conjunction with selection combining, maximum ratio combining, or equal gain combining as a receive diversity method in the up-link. Knowledge of the complex channel phase (equal gain combining) and/or amplitude (maximum ratio combining/selection combining) is typically needed to utilize receive diversity.

Transmit diversity has recently attracted considerable attention as a cost effective way to employ spatial diversity in the downlink of cellular systems. Transmit diversity methods can be characterized as either *closed loop* or *open loop* depending on whether the transmitter is provided with some prior knowledge of the channel. Polarization diversity uses the horizontal and vertical polarization of electromagnetic waves to theoretically double the antenna diversity order without the need for adding new antenna elements [19]. In practice, polarization diversity is better suited for indoor and microcell environments since for high BS antennas, the horizontal polarization can be typically 6–8 dB weaker than the vertical polarization resulting in reduced effective diversity gain. Angular diversity as a spatial filtering related method will be addressed in the following subsection.

1.1.2 Spatial filtering

Spatial filtering or beamforming can be applied to benefit from the angular spread and commonly different spatial signatures of the desired and interfering signals. Spatial filtering is achieved by the complex coefficient weighting and combining of signals induced on different spatially correlated antennas to form a single output of an array. For the given set of complex antenna weights, the direction in which the array has the maximum gain is typically called the beam pointing direction. The main advantage of applying beamforming in reception comes from the reduced CCI (filtering the desired from interfering users), ISI suppression (nulling the delayed signals arriving from directions other than the strongest one), and angular diversity (forming multiple beams and coherently combining the spatially filtered multipath components from different dominant scatterers). Similarly, in transmission, the energy can be spatially steered towards the desired user while minimizing the interference towards other users and the spatial pre-equalization can be applied so that signals coherently combine without ISI at a MS. Angular diversity gain becomes rather limited in the case of small angular spread where adjacent beams typically have received signal levels more than 10 dB weaker than the strongest beam. For accurate spatial filtering in reception and transmission, AOA and AOD estimation are required respectively for calculating the set of complex

antenna weights. Therefore, transmit beamforming inherently falls into the group of closed loop transmission schemes. In reciprocal channels, where AOA and AOD coincide, the estimated weights during the reception period are reused during the transmission period. A TDD system with a duplexing period smaller than the coherence time is a typical example where channel reciprocity holds. In nonreciprocal channels, a feedback channel is required for calculating optimal antenna weights for transmission. Furthermore, the antenna weights can be either fixed or calculated in an adaptive fashion according to some optimization criterion, i.e., maximization of the signal-to-interference-plus-noise-ratio (SINR).

Adaptive beamforming and AOA (AOD) estimation are commonly regarded as traditional array or space-only processing techniques. Temporal or time-only processing techniques employ adaptive equalizers to offer time domain CCI suppression and reduced ISI by complex coefficient weighting and combining of the temporally sampled signals. Space-time processing or smart antenna technology is loosely defined as any combination of space-only and time-only processing. It allows the advantages to be simultaneously exploited in both dimensions improving the different aspects in the performance of a radio communication system including system capacity, coverage, reduction in hand-off rate, quality of service in terms of throughput and probability of outage etc. For a comprehensive overview of the ST processing area see [5, 20, 21, 22, 23, 24, 25, 26, 27, 11, 28, 29, 30, 31]. As for the system capacity, a two-fold increase by employing ST processing is possible; an indirect increase through increase in the link capacity and a direct increase by allowing users in a given cell to share the same time/frequency and code resources based of their physical location or spatial separation. The latter benefit known as spatial-division multiple-access (SDMA) has attracted considerable attention in the recent past as it can be further coupled with any of the existing multiple-access methods [32, 33, 34, 11, 35].

1.2 MIMO channel capacity

In this thesis, the main focus is on the application of ST processing for improved link capacity. Therefore the following subsections briefly review the ultimate channel capacity limits of multiple-input multiple-output (MIMO) wireless channels that arise in general when antenna arrays are used at both sides of a wireless link.

1.2.1 Capacity expressions

Let us first assume an isolated single-user link operating in a frequency flat fading channel with M spatially uncorrelated receive antennas and a receiver with a perfect knowledge of channel state information (CSI). For a smart antenna constellation, employing beamforming over N spatially correlated transmit antennas and the maximum ratio combining over M spatially uncorrelated receive antennas, the

instantaneous capacity per unit bandwidth yields [36]

$$C_{\text{smart}} = \log_2 \left(1 + \frac{NP_{\text{T}}}{N_0} \sum_{m=1}^M |\alpha_{m1}|^2 \right) = \log_2 \left(1 + \frac{NP_{\text{T}}}{N_0} \chi_{2M}^2 \right) \quad (1.1)$$

where P_{T} denotes the average total transmitted power regardless of N , α_{m1} are instantaneous fading gains from the transmit antenna array to receive antenna m modelled as samples of independent identically distributed (i.i.d.) zero mean complex Gaussian random variables with variance 0.5 per dimension, i.e., $\alpha_{m1} \in \mathcal{CN}(0, 1)$. Additive white Gaussian noise (AWGN) at each receive antenna is modelled as $\mathcal{CN}(0, N_0)$ and χ_{2M}^2 are chi-squared random variables with $2M$ degrees of freedom. Signal-to-noise ratio (SNR) is defined per receive antenna as P_{T}/N_0 . In contrast to smart antennas, spatially uncorrelated antennas are sometimes regarded as *dumb* although there is nothing dumb in the related ST processing techniques. Assume now signalling over an array of N dumb antennas with an N dimensional transmitted signal vector \mathbf{x} as a unitary transformation \mathbf{V} of a vector comprising statistically independent components $\sim \mathcal{CN}(0, P_n)$ (for the virtue of the Gaussian code-book in maximization of mutual information, see [37]) and reception with a unitary transformation \mathbf{U}^{H} of an M dimensional received signal vector. The instantaneous capacity per unit bandwidth of such an (N, M) dumb antenna constellation becomes [38, 39, 40]

$$C_{\text{dumb}} = \log_2 \left\{ \det \left(\mathbf{I}_M + \frac{1}{N_0} \mathbf{H} \mathbf{P} \mathbf{H}^{\text{H}} \right) \right\} = \sum_{n=1}^N \log_2 \left(1 + \frac{P_n}{N_0} \lambda_{\mathbf{H},n} \right) \quad (1.2)$$

where \mathbf{I}_M denotes an $M \times M$ identity matrix, an $M \times N$ matrix \mathbf{H} contains in its (m, n) entry an i.i.d. $\alpha_{mn} \in \mathcal{CN}(0, 1)$ the instantaneous fading gain from transmit antenna n to receive antenna m , a matrix $\mathbf{P} = E[\mathbf{x}\mathbf{x}^{\text{H}}]$ having P_n as its n th eigenvalue denotes the covariance matrix of \mathbf{x} and $\lambda_{\mathbf{H},n}$ denotes the n th eigenvalue of $\mathbf{H}\mathbf{H}^{\text{H}}$ for $n = 1, \dots, \min(N, M)$ and is otherwise set to zero. Without knowledge of CSI at the transmitter, \mathbf{V} and \mathbf{U} reduce to identity matrices and optimal power shaping assumes an equal power allocation (EQPA) among the transmit antennas, i.e., $P_n = P_{\text{T}}/N$. Similarly, in the case of perfect prior knowledge of CSI at the transmitter, the columns of \mathbf{V} and \mathbf{U} are the eigenvectors of $\mathbf{H}^{\text{H}}\mathbf{H}$ and $\mathbf{H}\mathbf{H}^{\text{H}}$, respectively. The instantaneous capacity in (1.2) is maximized by the water-filling power allocation (WFPA) [40]

$$P_n = \left(\mu - \frac{N_0}{\lambda_{\mathbf{H},n}} \right)^+ \quad (1.3)$$

where $a^+ = \max(0, a)$ and μ comes from the constraint on the total transmitted power

$$\sum_{n=1}^N P_n = P_{\text{T}}. \quad (1.4)$$

For a smart antenna constellation, the antenna array gain and receiver diversity gain given by factors N and M in (1.1) contribute to a logarithmic increase in MIMO

channel capacity. According to (1.2), a dumb antenna constellation decomposes a MIMO channel into a multiple of rank $(\mathbf{H}) \leq \min(N, M)$ independent single-input single-output (SISO) spatial sub-channels whose gains are equal to non-zero eigenvalues of $\mathbf{H}\mathbf{H}^H$. Thus for spatially uncorrelated antennas at both sides of a wireless link, a MIMO channel capacity promises a linear increase with $\min(N, M)$. This fact was first recognized by simulations in the late 1980s [41] in the context of system capacity. It took until the mid 1990s to realize that mutually interfering and independent information streams from different users can also model different information sub-streams of a single user operating over multiple uncorrelated transmit antennas [38, 39, 40, 42].

When a transmission period is long enough to reveal the long-term ergodic properties of the fading process, the MIMO Shannon capacity is calculated by averaging (1.1) and (1.2) over the set of all channel realizations \mathbf{H} . For low mobility and/or delay constrained applications, a transmission session (code-word) can be well approximated to span a limited number of B statistically independent channel realizations [43]. Such channels are regarded as block fading channels where a special case of $B=1$ is commonly denoted as quasi-static. A block fading channel cannot be formulated in an ergodic or asymptotically stationary framework and its strict Shannon capacity is zero [43, 44]. With whatever small rate we attempt to communicate, there is a non-zero probability that the set of instantaneous channel realizations \mathbf{H} will not be able to support it, i.e., that the channel will experience an outage. Thus the capacity of non-ergodic channels is treated as a random variable with a certain probability of outage that is closely related to the code word error probability averaged over the set of all possible channel realizations.

Complementary cumulative distribution functions of outage capacities with EQPA for $B=1$ and different values of (N, M) including special cases of $(1, M)$, $(N, 1)$ and transmit cycling, i.e., (N, M) with one $(1, M)$ at a time, were calculated in [39] by combining (1.2) with Monte Carlo simulations. For high SNRs, MIMO capacity was reported to increase by $\min(N, M)$ more bps/Hz for every 3 dB increase in SNR as compared to a one increased bps/Hz in single antenna systems. The upper bound on (N, M) capacity was determined as an artificial case where, without interfering with each other, each of the N transmitted signal components is received by a separate set of M receive antennas. The lower bound on outage capacity

$$C_{\text{dumb}} > \sum_{i=N-(M-1)}^N \log_2 \left(1 + \frac{P_n}{N_0} \chi_{2i}^2 \right) \quad (1.5)$$

inspired some of the earliest MIMO signalling designs. In the (N, N) case, it is interpreted as the sum of the capacities of N independent channels with increasing diversity orders from 1 to N . The lower bound in (1.5) was determined to scale linearly with N for asymptotically large N [38]. The same linear increase with N in the asymptotically large N case for outage capacity with WFPA was demonstrated in [45, 46]. The slopes of asymptotically large N outage capacity growth were derived analytically as a function of SNR to conclude that the gain of WFPA over EQPA can be considerable in the low SNR region while it diminishes with the increase in SNR. The same conclusion was driven for small N based on simulations in

[47]. Moreover it was shown in [45] that the above asymptotic slopes do not depend on the distribution of α_{mn} in \mathbf{H} as long as they are i.i.d. Still, the knowledge of CSI at a transmitter enables MIMO channel capacity to be closely attained in practice by employing state-of-the-art single antenna channel codes in combination with a linear transformations at the transmitter and receiver. The capacity of deterministic MIMO channels with WFPA and the outage probabilities of quasi-static fading channels with EQPA were studied in [40]. Based on numerical integration over the statistical distribution of eigenvalues in (1.2) it was further shown in [40] that the ergodic capacity with EQPA increases linearly with N for (N, N) even for a small number of antennas. The slope of capacity growth as a function of SNR was given in closed form for large N (also in [48]).

A Gaussian assumption for the instantaneous capacity with EQPA in (1.2) with the mean equal to the ergodic capacity [40, 48] and the variance derived in [49] has been shown in [49] to offer a good approximation for virtually all values of N and M for both zero mean (Rayleigh fading) and non-zero mean (Ricean fading) i.i.d. complex Gaussian entries in \mathbf{H} . The variance was revealed to be insensitive to the number of antennas and influenced primarily by SNR. Since the non-zero eigenvalues of matrices $\mathbf{H}\mathbf{H}^H$ and $\mathbf{H}^H\mathbf{H}$ are the same, the reciprocity property was further concluded in [40] to hold in (1.2) for WFPA — $C_{\text{dumb}}(N, M, P_T) = C_{\text{dumb}}(M, N, P_T)$ and with the appropriate power scaling for EQPA — $C_{\text{dumb}}(N, M, P_T N) = C_{\text{dumb}}(M, N, P_T M)$. In the special cases of $(N, 1)$ and $(1, M)$, the channel is referred to as multiple-input single-output (MISO) and single-input multiple-output (SIMO), respectively. The MISO case was further studied in conjunction with some practical transmit diversity schemes in [50] and the SIMO case under different adaptive transmission and receiver antenna diversity combining methods in [51, 52]. A selection transmit antenna diversity was examined in [53, 54, 55, 56]. An evaluation of capacity for delay limited block fading channels ($B \geq 1$) with CSI known at both ends of a wireless link and with optimal power allocation that minimizes the outage probability under short and long term total transmitted power constraints was derived in [57, 58, 59]. A linear increase in delay limited capacity with N for the (N, N) case was demonstrated even for low values of N based on a semi-analytical approach. Delay limited capacity was further shown to be almost independent of B and to approach the ergodic capacity for large N .

An example of non-coherent MIMO communication where neither the receiver nor the transmitter have knowledge of CSI was studied in [60]. A frequency flat, block fading channel was assumed to be constant for a coherence time of T symbols before changing to a new independent state. It was proven that increasing N beyond T does not increase capacity. Also, by increasing T for a fixed (N, M) , the capacity approaches the level obtained with a perfect knowledge of CSI at the receiver. An explicit formula for average capacity with (N, M) , $T \geq 2N$, and high SNR was derived in [61, 62, 63]. Instead of $\min(N, M)$ more bps/Hz increase for every 3 dB increase in SNR encountered in MIMO channels with coherent signalling, the capacity gain of MIMO channels with non-coherent signalling is $[\min(N, M, \lfloor T/2 \rfloor)](1 - [\min(N, M, \lfloor T/2 \rfloor)]/T)$.

1.2.2 Spatial channel models

Releasing the independence (un-correlated) assumption for channel gains α_{mn} in \mathbf{H} does not change the definition of MIMO channel capacity in (1.2) but may either decrease rank(\mathbf{H}) or cause a certain number of eigenvalues $\lambda_{\mathbf{H},n}$ to become too small to convey reliably information. In both cases, the effective number of parallel SISO sub-channels may be considerably reduced. Therefore the channel capacity gain of MIMO over a SISO antenna system may be decreased. The effect of spatial correlation on eigenvalue distribution was studied in [64] based on a ray-tracing simulation model which assumed an isolated unobstructed BS and one ring of scatterers around an MS. Parameters such as the distance between BS and MS, the radius of a scattering ring at the MS, AOA and angular spread at the BS, and the geometrical arrangement of the antennas in the two arrays were varied to study the impact on the outage capacity with EQPA. For line-of-sight (LOS) environments, ray tracing was used in [65, 66] to construct a channel matrix explicitly for some example environments and to find array geometries which in the (N, N) case result in N non-negligible eigenvalues. The influence of different array configurations was further examined in [67, 68]. Based on channel matrix factorization, the analysis in [45] shows that even in the case of correlated entries in \mathbf{H} , the outage capacity for quasi-static MIMO fading channels with both EQPA and WFPA increase linearly with N for asymptotically large N in the (N, N) case. However the slope of such an asymptotic increase is generally different to that in the i.i.d. case. Interestingly, at low SNRs, for EQPA there is no penalty in the above slope due to the spatial correlation while with WFPA, such the slope even increases as the correlation becomes stronger. For high SNRs the rate of growth for both EQPA and WFPA are reduced by correlation and the difference between the two rates approaches zero similar to the i.i.d. case. Ray tracing simulations with the propagation effects of scattering, reflection, and diffraction derived from a multilayer dielectric model of an indoor office environment confirmed the conclusions. An approximate mean and variance of eigenvalues $\lambda_{\mathbf{H},n}$ in (1.2) was derived in [69] for asymptotically large either N or M allowing for correlation at both sides of the wireless link. Simulations demonstrated that a Gaussian distribution with the above first and second order statistical moments gives a good approximation for eigenvalue distribution.

Instead of being comprised of i.i.d. complex Gaussian entries, the channel matrix \mathbf{H} in [42] was represented as a sum over L_M individual multipath components each factored by the complex path amplitude and associated transmit and receive array response vectors. Multipaths were assumed to spread in both the angular and delay domain. Since the assumed equivalent channel model for each multipath always has rank one, the number of finite-amplitude parallel spatial sub-channels was shown to be limited by $\min(N, M, L_M)$ which gives an excellent insight into how crucial the rich scattering environment is to a channel's ability to provide parallelism. Based on the above parametric channel model and with the assumption of only angular spread, a comprehensive study was conducted in [70] on outage capacity for different numbers of resolvable multipaths and their angular spreads, array structures, and degrees of knowledge of CSI at the transmitter. A different model for angular and delay spreads in wireless channels was introduced in [71, 72]. Each multipath

was identified by its own cluster of scatters with cluster specific delay, complex gain, the mean AOA at the BS, and the angular spread proportional to the cluster radius. The above parameters were utilized to define the spatial fading correlation at the BS for each multipath. Fading at the MS was assumed to be spatially uncorrelated. An $M \times N$ channel matrix was given as a sum of L_M , $M \times N$ matrices, each proportional to the multipath specific spatial correlation matrix. Based on the above channel model, outage and mean capacities of multi-antenna frequency selective fading channels constrained by a finite number of sub-carriers in the assumed MIMO-OFDM signalling were evaluated in [71, 72]. Notice that only in the limiting case of infinitesimal sub-carriers, the MIMO-OFDM signalling capacity approaches the exact capacity of the underlying space-frequency channel. Papers [71, 72] assumed an exponential power delay profile. The MIMO link capacity constrained by the finite signalling constellation was evaluated in [73]. The effect of imperfect CSI on ergodic MIMO capacity was studied in [74].

The effect of fading correlation at the receiver end on ergodic MIMO channel capacity with EQPA was further studied semi-analytically using uniform [75] and exponential [76] models for a channel correlation matrix originally developed for diversity combining methods. Owing to the reciprocity property of capacity, this analysis was extended to transmit antenna correlations and further combined to capture the effects of correlations at both sides of the wireless link [77]. For analytical tractability, the (pj, qk) entry in an $MN \times MN$ dimensional channel correlation matrix was assumed in [45, 77, 69] to be a product of entries (j, k) and (p, q) in $N \times N$ transmit-only and $M \times M$ receive-only correlation matrices respectively, i.e., $E[\alpha_{pj}\alpha_{qk}^*] = E[\alpha_{1j}\alpha_{1k}^*]E[\alpha_{p1}\alpha_{q1}^*]$. This assumption was validated by simulations in [45] and by measurements in [78]. Results of different MIMO channel measurement campaigns were further reported in [79, 80, 81, 82, 83, 84, 85]. Results in [84] show that AOA at the MS is not uniformly distributed around 360° in azimuth causing the measured median coherence distance and time to be roughly twice of that predicted by theory [2], although the overall measured MIMO channel capacity was concluded not to be considerably affected. The low spatial correlation achieved through wide-enough antenna separation in rich scattering environments was considered the only necessary condition for high rank behavior of MIMO channels until the existence of a degenerate MIMO channel phenomena entitled ‘‘pin-hole’’ in [86] or ‘‘key-hole’’ in [87] was revealed. Despite the zero correlation of entries in \mathbf{H} , whenever the energy between transmitter and receiver arrays travels through a very thin air pipe, the rank value of \mathbf{H} does not exceed the single degree of freedom. An example of a key-hole channel in practice arises when the product of a transmitter and receiver scattering radii is small compared to the distance between the transmitter and the receiver [64, 86, 65]. Other examples including propagation through a waveguide, i.e., a hallway or a tunnel and roof edge diffraction were further studied in [87].

The conclusions driven in this section were restrained by the assumption of an isolated single-user link in (1.1), (1.2). In addition to antenna array gain, smart antennas in multi-user environment offer improved SINR through the spatial filtering of multiple-access interference (MAI) and CCI. In spite of the necessary knowledge of AOD at the transmitter, beamforming requires estimation of fewer channel pa-

rameters compared to dumb antenna processing — AOD plus a minimum of M channel coefficients for a smart antenna array compared to a minimum of MN channel parameters for a dumb antenna array. The optimal signalling strategies that maximize the system and channel capacities of MIMO dumb antenna constellations in the presence of MAI and CCI are not well understood to date. While some early conclusions were initiated in [36, 33, 40, 88, 89, 90, 91, 92] the universal understanding on the applicability and the advantages of dumb compared to smart antenna arrays in different radio communication scenarios is an interesting open topic.

1.3 Aim and outline of the thesis

The existing voice-oriented, fixed and mobile radio communication networks are typically designed to accommodate a large number of low data rate users. With the emergence of wireless data services, user data rates are becoming increasingly variable and heterogenous. Future mobile networks will therefore be mainly characterized by a horizontal communication model where different access technologies such as cellular mobile, broadband wireless access, wireless local area networks (WLANs), and short range connectivity systems are combined on a common platform to complement each other in an optimum way for different service requirements and radio environments. The ability to provide high peak-data rates to individual users and concentrate large amounts of traffic in localized spots will be one of the key metrics to evaluate communication systems in the future. The spatial domain has already been identified as the most promising frontier for bandwidth efficiency improvement. Consequently the development of advanced ST processing algorithms for dumb antenna configurations will become a crucial issue in the coming age of wireless data.

Novel ST signalling methods and transceiver algorithms for reliable and bandwidth efficient transmission approaching MIMO link capacity limits are designed and analyzed in this thesis. The work concentrates on coherent ST coding schemes designed under the assumption of no available CSI at the transmitter and estimated CSI at the receiver. As an original contribution, the thesis proposes the robust space-time turbo coded modulation (STTuCM) as an extension of single antenna turbo coded modulation (TuCM) to multiple antenna systems. Although both parallel and serial concatenated STTuCM have been introduced, the main focus has been placed on the parallel code concatenation. Presented as a collection of twelve original publications enclosed as appendices I – XII, the thesis is further organized as follows.

Chapter 2 introduces the basic concepts and background knowledge to place in context the main contributions of the thesis developed as the combination of turbo coding and space-time coding. The relevant developments in turbo coding are first surveyed. Evolution of the probability of erroneous transmission over representative MIMO fading channels is then presented using assumption of optimal maximum likelihood decoding (MLD) at a receiver. Finally, the state of the art in space-time

coding design that preceded, but also evolved in parallel to the development of this thesis, is reviewed.

Chapter 3 presents the scope of the thesis. Several interesting open problems that motivated this work are first introduced. The main contributions of the thesis are briefly summarized and the relation to closely related parallel work on space-time turbo coding established afterwards.

Chapter 4 includes the summary of the original publications that address different aspects of the newly introduced STTuCM. These include: the system model; performance evaluation under different narrow-band frequency-flat block fading channels; application combined with some novel transceiver designs for future wide-band CDMA (WCDMA) and OFDM based broadband communication systems; the distance spectrum (DS) interpretation and the union bound (UB) performance analysis for slow and fast fading channels; the convergence analysis of iterative decoding; constituent code (CC) design based on the DS optimization and iterative decoding convergence analysis; and the impact of bit-wise and symbol-wise information interleaving to the performance of STTuCM.

Chapter 5 concludes the thesis discussing its main results and contributions. Directions for further development and open problems for future research are also described.

The presentation style was carefully chosen to make the thesis accessible to both experts in the area and to less experienced readers. After observing the scope of the thesis in Chapter 3, a proficient reader should be able to grasp different vital contributions of the thesis by directly examining the appended, self-contained papers of particular interest. The less proficient reader is gradually introduced throughout Chapters 2, 3, and 4 to the relevant background necessary for understanding the advanced topics covered in the appended papers. Since some of the notations and definitions are inevitably repeated throughout the papers to assure that they are self-contained, to a certain extent the presentation compromises on the conciseness of the thesis.

2 Literature survey

The relevant background literature describing the concept of space-time turbo coded modulation (STTuCM) is reviewed in this chapter. Without the intention of performing an extensive coverage of the topic, Section 2.1 surveys the important aspects of turbo coding related to this thesis. The state of the art in space-time coding design that preceded but also evolved in parallel to the development of this thesis is reviewed in Section 2.2.

2.1 Turbo coding

Turbo codes (TuCs) were introduced in [93, 94] as a parallel concatenated coding scheme consisting of two binary recursive systematic convolutional codes linked by an information interleaver. The information bits at the input of the first encoder were scrambled by the information interleaver before entering the second encoder. Due to systematic CCs, the codewords of the proposed scheme consisted of the information bits followed by the parity check bits from two encoders, which combined with puncturing provided a variety of coding rates. Showing remarkable performance close to the Shannon limit with an applied sub-optimal low complexity iterative decoding algorithm, the simulation results in [93] initially raised scepticism. Independently reproduced by several researchers soon after [95, 96, 97] they triggered a large amount of research effort focused on understanding the reasons for such outstanding performance. Although their design did not follow any particular optimization criterion, a careful examination of the literature shows that rather than being a sudden apparition, TuCs resulted from clever intuition built at the intersection of three main concepts already established: combining several codes by product or concatenation, the random-like code design criterion, and that of extending the decoding role to reassess probabilities [98]. Shannon's channel coding theorem [37] implies that reliable transmission with rates below channel capacity can be achieved with a randomly chosen block or convolutional code as long as its block or constraint length is very long. However, the MLD required

to achieve an arbitrary low probability of error becomes physically un-realizable in such a case. The research in coding theory over the past 50 years has seen many proposals aimed at constructing powerful codes with large equivalent block or constraint lengths structured so as to permit breaking the MLD into simpler partial decoding steps. Iterated codes [99], product codes [100], concatenated codes [101], and large constraint convolutional codes with sub-optimal decoding strategies like sequential decoding [102, 103] are non-exhaustive examples of such attempts. The most popular of these schemes, applied to deep space probes, consists of a Reed-Solomon outer code followed by a convolutional inner code. Although Shannon's coding theorem suggests that a code designed to have a distance distribution close to that of random coding should be a good code [98], the challenge of finding practical decoding algorithms for random-like codes has not been seriously tackled until the introduction of TuCs. Extending the decoding role to reassess the probabilities principle is based on iterative decoding. This is the strategy of alternatively decoding simple CCs with soft-input soft-output (SfISfO) decoders and passing so-called *extrinsic information* as a part of decoder's soft output a *posteriori* probability to the next stage of decoding. TuCs therefore cleverly integrate code concatenation in a random-like coding approach where large equivalent constraint length and randomness are jointly provided by an information interleaver, a building block that due to iterative decoding does not add to decoding complexity. The authors coined their novel coding concept *turbo* due to the decoder that uses its processed output values as a *priori* inputs for the next iteration, much like the exchange between the turbine and the compressor in a turbo-engine.

2.1.1 Design and principles

To date, a huge number of publications in the literature including a few books [104, 105], journal special issues [106, 107, 108] and international symposiums [109, 110] have been devoted entirely to the developments in this new branch of coding theory. The DS interpretation and the UB performance analysis over AWGN and fading channels in [111, 97, 112, 113, 114, 115, 116, 117, 118] unveiled the importance of multiplicities and error exponents in TuC's DS. The combination of recursive CCs and information interleaving contribute to the effect of *spectral thinning* in which information sequences that generate low weight codewords from the first CC are interleaved with high probability to information sequences that generate high-weight codewords in the second CC. Very large information interleavers increase such probability resulting in a DS with a few low-weight codewords and a large number of average-weight codewords similar to the DS of random-like codes [98]. It was further shown in [113] that the CCs need not necessarily be systematic. The *free distance* and the first several spectral lines above it are solely determined by the weight-two information sequences. The minimum weight among CCs' codewords caused by those weight two information sequences is denoted as the *effective free distance*. The maximization of the effective free distance was therefore the main design criteria for CC optimization in [119, 120, 121, 122], quite different from

the optimization criteria used for stand-alone convolutional codes [123]. In [124] the optimization considered the information sequences of weight up to six while in [125] CCs were designed optimizing the TuC's DS in the area of low to medium distances, i.e., significant spectral lines. The UB analysis showed that the sub-optimal iterative decoding closely approaches the MLD performance bound for an increasing number of iterations. To make the analysis tractable the interleaver between CCs was assumed to be random with uniform distribution resulting in an upper bound to the performance of MLD averaged over all different information interleavers. Simulations showed that a reasonable choice of interleaver easily leads to performance close to the average. Therefore in the area of low and moderate SNRs where performance is mainly determined by the large number of average-weight codewords the choice of a particular information interleaver realization is not critical as opposed to its length which is indeed the main reason for the good performance of TuCs [113]. However, the well designed information interleaver [126, 127, 128, 129, 130, 125, 131] plays an important role in determining the first several spectral lines [112, 113] that limit the asymptotic behavior of any code at high SNR. The information interleaving design for simultaneous termination of both CCs was studied in [132, 133, 131], the performance with short information interleavers in [134, 135], and the effects of puncturing to the DS in [136, 137]. A rate adaptation of TuCs through frequent trellis termination of their CCs was studied in [138].

Different variants of SflSfO decoders are mainly classified depending on whether they were derived from the Viterbi algorithm [139] or symbol-by-symbol maximum a posteriori probability (MAP) algorithm [140] optimized for the minimum sequence or the minimum symbol error rate, respectively. Since the two optimization criteria are asymptotically the same at high SNR, the memory and computationally more demanding MAP was for a long time abandoned until its modification, adapted to produce a log-likelihood-ratio (LLR) of information bits entering the binary recursive systematic convolutional trellises, was reinvented for constituent TuC decoders in [93]. Since then, various modifications of the bit-by-bit MAP algorithm have been seen in the literature [95, 141, 142, 143, 144, 145]. To alleviate sensitivity to numerical precision due to the large dynamic range of probabilities processed, most of such algorithms allow for logarithmic domain representation (log-MAP) and further sub-optimal simplification (max-log-MAP) by neglecting the second term in the *Jacobian logarithm* $\ln(e^x + e^y) = \max(x, y) + \ln(1 + \exp\{-|y - x|\})$ [146, 147, 148]. Unlike max-log-MAP, MAP and log-MAP theoretically require an estimate of the SNR but have been shown to be quite robust to SNR mismatch in practice [149]. The soft output Viterbi algorithm (SOVA) was introduced in [150] and applied to component TuC decoders in [96]. Different SOVA modifications were proposed in [151, 152, 153]. Compared to MAP, SOVA suffers from some performance degradation [147, 148] but is generally less complex and does not require SNR estimation.

Embedding in the SflSfO decoder's soft outputs a posteriori probabilities of encoder's both inputs and outputs, derivation of the MAP in [143, 144] enabled the application of iterative decoding to a general class of coding networks, i.e., hybrid parallel-serial concatenations of interleaved convolutional codes [154, 155]. Distance

spectrum interpretation, UB analysis, CC design, and performance evaluation over AWGN and fading channels of serially concatenated convolutional codes were studied in [156, 157, 158, 159, 160, 161, 162]. The serially concatenated convolutional code with the recursive rate one inner code was proposed in [163] and double serially concatenated convolutional code in [164]. To maximize the interleaving gain, the inner CC in a serially concatenated convolutional code should be a recursive systematic convolutional with the maximized effective free distance. The outer code should be a non-recursive convolutional code with large, and possibly odd, value of the free distance. In [165], the iterative decoding concept was extended to the parallel concatenation of block codes.

Summarizing the main conclusions from Shannon's theory on digital communications, Viterbi outlined in 1991 [166] that the optimal receiver should "never prematurely discard the information that may be useful in making a decision until after all decisions related to that information have been completed". Soon after the introduction of TuCs in 1993, it became clear that the method employed for iterative decoding of concatenated codes is more universal. The fundamental strategy of iterative exchange of soft information between the different building blocks in a communication receiver, also coined the *turbo principle* by Hagenauer in 1997 [167], has been shown for many applications to yield near optimal receiver performance with reasonable implementation complexity. The turbo principle is now successfully applied as a remedy for a wide range of problems in communication systems that extend well beyond channel coding, i.e., iterative demodulation and decoding [168, 169, 170, 171]; iterative equalization and decoding [172, 173, 174, 175, 176, 177, 178, 179, 180]; iterative interference suppression and decoding [181], iterative multi-user detection and decoding [182, 183, 184, 185, 186, 187, 147, 188, 189, 190]; iterative CSI estimation and decoding [191, 192, 138]; joint source-channel decoding [193].

2.1.2 Turbo coded modulation

TuCs were originally introduced in [93] for binary phase shift keying (BPSK) modulation. Attempts to improve spectral efficiency by combining TuCs with higher order phase or amplitude modulations have brought many proposals for turbo coded modulations (TuCMs) [194, 195, 196, 197]. In [194] the binary outputs of a TuC were punctured and interleaved after which they were associated through Gray mapping to in-phase and quadrature branches in a quadrature amplitude modulation (QAM). At the receiver, the LLRs for each encoded bit were calculated by the soft output demodulator and after de-interleaving passed to a standard binary turbo decoder. Such a pragmatic TuCM approach was further studied in [198, 199, 200, 201] in the context of bit-interleaved coded modulation (BICM) [202, 203, 204] which separates the selection of the coding scheme and the modulation scheme.

In [195, 205, 206], binary TuCs with different degrees of puncturing were applied as component codes for multi-level coded modulation [207, 208, 209], the combined coding-modulation approach where the signalling constellation is partitioned in the subsets in the form of a binary tree and where the output of an independent bi-

nary encoder governs the selection of a subset in each level of partition. Signalling constellation subsets are decoded one at a time, employing binary decoders for each level of partition. Such a sub-optimal multi-stage decoding strategy considerably reduces the complexity compared to the optimal MLD and asymptotically approaches the channel capacity if the rates at different levels of partitioning are chosen appropriately.

In an analogy to binary TuCs, the TuCM in [196, 210, 211] employed for CCs in the punctured parallel concatenation, the recursive systematic form of a trellis coded modulation (TrCM). Originally introduced by Ungerboeck in [212] as an integrated trellis coding and higher order modulation approach, the TrCM offers significant coding gains, i.e., reduced minimum required SNR for achieving certain probability of error, compared to un-coded systems without sacrificing data rates or bandwidth efficiency. Since a truly exhaustive computer search for good TrCMs would be impractical even for moderate constraint lengths, a mapping by set partitioning has been established as a rule of thumb for restricting the searched class of codes. Therefore TrCM can be thought of as a special case of multi-level coded modulation. The signalling constellation is partitioned in the subsets in the form of a binary tree but unlike multi-level coded modulation the selection of a subset in each level of partitioning is governed by the trellis transitions whether they are parallel, diverge/re-merge from/to the same state. Each trellis transition can also correspond to multiple symbol transmissions which is referred to as multiple TrCM. The theory of TrCM over AWGN and fading channels is nowadays well established [213, 214, 215, 216, 217, 218, 219, 220, 221, 222, 223]. In each trellis transition during a transmission frame, adopting a number of consecutive input bits denoted as the input symbol, a trellis of a component TrCM in TuCM from [210] produces an output complex signal from the multidimensional complex constellation. Puncturing assumed that every second output complex symbol from the first component TrCM was time multiplexed with every other second output complex symbol from the second component TrCM. To assure that each information bit contributes exactly once to the output TuCM codeword, a pseudo-random symbol-wise information interleaver between component TrCMs was employed that maps even symbol positions to even symbol positions and odd ones to odd ones. In addition it assures that the ordering of input bits within given input symbol remains unchanged, i.e., a symbol-wise odd-even information interleaver. At the receiver the component codes in TuCM were decoded with a symbol-by-symbol MAP decoder in an iterative fashion. Further improvements in the encoder and the decoder of TuCM from [196] were studied in [224].

A somewhat different approach to TuCM was proposed in [197, 225]. During each trellis transition the recursive systematic binary trellis of the CC in the parallel concatenation, adopting an even number of consecutive input bits denoted as the input symbol, produces a number of unmodulated output bits. Half of the systematic bits were punctured in each encoder and the remaining systematic and parity bits were suitably mapped to a multidimensional complex constellation. At the receiver, the LLRs for each encoded bit were calculated by the soft output demodulator and passed to the corresponding symbol-by-symbol MAP decoder. To assure that each information bit contributes exactly once to the output TuCM

codeword, the interleaver between CCs consisted of a number of pseudo-random bit-wise interleavers, independently mapping each bit in the input symbol. Due to bit level information interleaving the symbol level LLR at the output of the symbol-by-symbol MAP decoder needs to be projected to the bit level LLR before its interleaved (de-interleaved) version could be passed to the input of another symbol-by-symbol MAP decoder, i.e., TuCM operates on the bit level despite its component symbol level MAP decoders. When all the implemented information interleavers have the same pattern, the ordering of information bits in the input symbol remain unchanged, which is equivalent to symbol level information interleaving. In this particular case component symbol-by-symbol MAP decoders can directly exchange their symbol LLRs, i.e., TuCM operates on the symbol level. The convergence properties of iterative decoding, CC code optimization and information interleaving design for bit level and symbol level TuCM from [197] were studied recently in [226, 227, 228, 229]. Different TuCMs were further examined over AWGN and fading channels in [230, 231, 232, 233] and in the context of adaptive modulation in [234, 235].

The existing UB analysis of TuCM over AWGN [236, 237, 238] and fading [239] channels in the literature mainly considered the special case of binary TuCs followed by a channel interleaver and complex constellation mapper. The performance evaluation of TuCM from [196] was recently studied over AWGN channels in [240]. The performance bounds of multilevel TuCM were studied in [206]. Unlike parallel concatenated TuCMs, the design of serial concatenated TuCMs is more straightforward. Due to the inevitable signal constellation mapping that can be either integrated within the inner code, i.e., an inner TrCM, or separated from it by an additional interleaver, i.e., an inner BICM, any of the serially concatenated convolutional codes from Subsection 2.1.1 can be also characterized as serially concatenated TuCMs.

2.2 Space-time coding

To exploit the potentially large link capacities of MIMO fading channels, a considerable amount of research has been focused on ST processing for arrays of uncorrelated antennas at both ends of a wireless link. Such ST signalling designs evolved along three main paths characterized by the assumptions of CSI knowledge. The first path comprises the non-coherent, so called differential, or unitary ST coding schemes where neither receiver nor transmitter has CSI [241, 242, 243, 244, 245, 246, 247, 248, 245]. The second path targeted the signalling schemes that benefit from the channel reciprocity, or the existence of an unlimited capacity feedback channel, where CSI is available at both transceiver ends [58, 249, 250, 251, 252]. The third path, which is examined in this thesis, tackles the design of coherent ST coding schemes optimized on the assumption of no available CSI at a transmitter and estimated CSI at the receiver. Here we also outline that the last path allows for the adaptive implementation that exercises the limited CSI fed to the transmitter through a typically low capacity feedback channel.

Before introducing the main contributions of the coherent ST coding schemes in the literature, the probability of erroneous transmission over some representative MIMO channels with the assumption of optimal MLD at a receiver will be briefly examined in Subsection 2.2.1. The MIMO channel capacity limits from Section 1.2 as well as the MLD error performance analysis from the following Subsection 2.2.1 are responsible for inspiring much of the current coherent STC designs in the literature. Their adequate characterization is however not straightforward. The schemes employing the optimal MLD at a receiver are commonly qualified as the optimal ST coding schemes to distinguish from the sub-optimal ST coding schemes featuring different reduced complexity sub-optimal linear and decision feedback receiver interfaces. As will be apparent after Subsection 2.2.1, the code design criteria based on the minimal pair-wise error probability (PEP) with MLD were defined using the baseband signal matrices with no assumptions on the modulation constellation or the underlying code structures, leaving substantial room for optimal ST coding designs. Subsections 2.2.2 and 2.2.3 briefly survey the two main categories of optimal ST coding schemes, namely space-time coded modulation (STCM) and space-time block codes (STBCs) as part of a more general class of transmit diversity schemes. Originally inspired by the lower bound on MIMO channel capacity in (1.5), the layered ST coding architectures employing different sub-optimal receivers are reviewed in Subsection 2.2.4.

2.2.1 MIMO channel reliability

Consider a transmission with a coherent STC over a frequency-flat isolated single-user link with N transmit and M receive antennas. Each STC codeword spans L time epochs and during each time slot, N symbols are simultaneously transmitted over N transmit antennas. Let $c_n(l)$ denote the baseband constellation symbol with a unit average energy that is transmitted from antenna n , $n = 1, \dots, N$ at time instant l , $l = 1, \dots, L$. The sampled output of a matched filter at each receive antenna m , $m = 1, \dots, M$ is a noisy superposition of N transmitted signals impaired by fading

$$r_m(l) = \sqrt{E_s} \sum_{n=1}^N c_n(l) \alpha_{mn}(l) + \eta_m(l) \quad (2.1)$$

where (referring to Section 1.2) $E_s = P_T/N$, $\alpha_{mn}(l) \in \mathcal{CN}(0, 1)$ are fading samples and $\eta_m(l) \in \mathcal{CN}(0, N_0)$ are additive white Gaussian noise (AWGN) samples. The unified approach to the evaluation of PEP for any coherent communication system including transmitter and receiver diversity systems with an arbitrary level of temporal and spatial fading correlation was presented in [253]. Let the $L \times NL$ block matrix $\mathbf{D}_c = [\mathbf{D}_c(1), \dots, \mathbf{D}_c(N)]$ represent the transmitted STC codeword with each $L \times L$ matrix $\mathbf{D}_c(n) = \text{diag}[c_n(1), \dots, c_n(L)]$. Assume for a moment $M = 1$. We may rewrite (2.1) in matrix form

$$\mathbf{r}_1 = \sqrt{E_s} \mathbf{D}_c \boldsymbol{\alpha}_1 + \boldsymbol{\eta}_1 \quad (2.2)$$

where $\mathbf{r}_1 = [r_1(1), \dots, r_1(L)]^T$, $\boldsymbol{\alpha}_1 = [\boldsymbol{\alpha}_{11}^T, \dots, \boldsymbol{\alpha}_{1N}^T]^T$ with $\boldsymbol{\alpha}_{1n} = [\alpha_{1n}(1), \dots, \alpha_{1n}(L)]^T$, $\boldsymbol{\eta}_1 = [\eta_1(1), \dots, \eta_1(L)]^T$. As in [253], we define the ‘‘signal’’ matrix (SM)

$$\mathbf{C}_{s,1} = \mathbf{D}_{ec} \mathbf{C}_{\boldsymbol{\alpha}_1} \mathbf{D}_{ec}^H \quad (2.3)$$

where $\mathbf{D}_{ec} = \mathbf{D}_e - \mathbf{D}_c$ denotes a codeword difference matrix and $\mathbf{C}_{\boldsymbol{\alpha}_1} = E[\boldsymbol{\alpha}_1 \boldsymbol{\alpha}_1^H]$ is a covariance matrix of a MISO channel. Assuming MLD with perfectly estimated CSI at the receiver, the PEP of deciding in favor of codeword \mathbf{D}_e when codeword \mathbf{D}_c was actually transmitted, i.e., $\{\mathbf{D}_c \rightarrow \mathbf{D}_e\}$ has been determined in [253] to be a polynomial function of SNR and the eigenvalues of the SM. Based on the exact polynomial PEP function, a new simplified PEP bound that is tighter than the standard Chernoff bound in [254] and asymptotically tight with high SNR has been derived in [253] as

$$P_r\{\mathbf{D}_c \rightarrow \mathbf{D}_e\} \leq \left(\frac{2\Delta_H(\mathbf{C}_{s,1}) - 1}{\Delta_H(\mathbf{C}_{s,1}) - 1} \right) \left(\prod_{i=1}^{\Delta_H(\mathbf{C}_{s,1})} \lambda_i(\mathbf{C}_{s,1}) \right)^{-1} \left(\frac{E_s}{N_0} \right)^{-\Delta_H(\mathbf{C}_{s,1})} \quad (2.4)$$

where $\Delta_H(\mathbf{C}_{s,1})$ is the rank of the SM $\mathbf{C}_{s,1}$ and $\lambda_i(\mathbf{C}_{s,1})$ are its non-zero eigenvalues whose geometric mean will be expressed by $\Delta_P(\mathbf{C}_{s,1})$ in the sequel. Although in general they are not true distances in the mathematical sense, $\Delta_H(\mathbf{C}_{s,1})$ and $\Delta_P(\mathbf{C}_{s,1})$ are commonly denoted as the effective Hamming distance (EHD) and the effective product distance (EPD) respectively between \mathbf{D}_e and \mathbf{D}_c . Only in the special case of an AWGN channel when components of $\boldsymbol{\alpha}_1$ are all ones, a covariance matrix of a channel $\mathbf{C}_{\boldsymbol{\alpha}_1}$ becomes an all ones matrix, which reduces the SM to a rank one matrix, i.e., $\Delta_H(\mathbf{C}_{s,1\text{awgn}}) = 1$, with its only non-zero eigenvalue $\lambda_1(\mathbf{C}_{s,1\text{awgn}}) = \Delta_P(\mathbf{C}_{s,1\text{awgn}})$ being a squared Euclidean distance between \mathbf{D}_e and \mathbf{D}_c

$$\Delta_P(\mathbf{C}_{s,1\text{awgn}}) = \sum_{l=1}^L \sum_{n=1}^N |\Delta_n^{ec}(l)|^2 \quad (2.5)$$

where $\Delta_n^{ec}(l) = e_n(l) - c_n(l)$. In the case of spatially uncorrelated transmit antennas the channel covariance matrix in (2.3) is a block diagonal $\mathbf{C}_{\boldsymbol{\alpha}_1} = \text{diag}[\mathbf{C}_{\boldsymbol{\alpha}_{11}}, \dots, \mathbf{C}_{\boldsymbol{\alpha}_{1N}}]$ with an $L \times L$ matrix $\mathbf{C}_{\boldsymbol{\alpha}_{1n}}$ determined by the Doppler spread of the channel. The two special cases of the Doppler spread that are of special interest for ST coding optimization are considered in the following. For temporally correlated fading, i.e., slow or quasi-static fading, where $\mathbf{C}_{\boldsymbol{\alpha}_{1n}}$ is an all ones matrix, (2.3) is given as

$$\mathbf{C}_{s,1\text{slow}} = \sum_{n=1}^N [\Delta_n^{ec}(1), \dots, \Delta_n^{ec}(L)]^T [\Delta_n^{ec}(1), \dots, \Delta_n^{ec}(L)]^*. \quad (2.6)$$

Since the epoch-by-epoch calculable matrix

$$\tilde{\mathbf{C}}_{s,1\text{slow}} = \sum_{l=1}^L [\Delta_1^{ec}(l), \dots, \Delta_N^{ec}(l)]^H [\Delta_1^{ec}(l), \dots, \Delta_N^{ec}(l)] \quad (2.7)$$

has the same non-zero eigenvalues as matrix $\mathbf{C}_{s,1\text{slow}}$, Δ_{H} and λ_i in (2.4) are commonly calculated based on the eigenvalue-equivalent SM in (2.7). The EPD in such a case is equal to the Δ_{H}^{-1} th power of the absolute value of the sum of determinants of all the principal $\Delta_{\text{H}} \times \Delta_{\text{H}}$ co-factors of the eigenvalue-equivalent SM in (2.7) [254]. Notice also that $\Delta_{\text{P}}(\mathbf{C}_{s,1\text{awgn}})$ in (2.5) is equal to the trace of the eigenvalue-equivalent SM in (2.7). For temporally uncorrelated fading, i.e., fast or ideally interleaved fading, $\mathbf{C}_{\alpha_{1n}}$ is an $L \times L$ identity matrix for which (2.3) reduces to

$$\mathbf{C}_{s,1\text{fast}} = \sum_{n=1}^N \mathbf{D}_{ec}(n) \mathbf{D}_{ec}(n)^{\text{H}}. \quad (2.8)$$

The l th eigenvalue of $\mathbf{C}_{s,1\text{fast}}$ depends only on the transmitted signals at time instant l

$$\lambda_l(\mathbf{C}_{s,1\text{fast}}) = [\Delta_1^{ec}(l), \dots, \Delta_N^{ec}(l)] [\Delta_1^{ec}(l), \dots, \Delta_N^{ec}(l)]^{\text{H}}, \quad l = 1, \dots, L \quad (2.9)$$

and $\Delta_{\text{H}}(\mathbf{C}_{s,1\text{fast}})$ is the cardinality of a set of time instances in which eigenvalues in (2.9) are non-zero.

Determining the slope of the performance curve in the logarithmic domain at high SNR, the minimum value of EHD over all \mathbf{D}_{ec} measures the amount of diversity available in the decision process. The EPD is responsible for the horizontal parallel shift of the performance curve as a function of SNR and its minimum value over all \mathbf{D}_{ec} measures the coding gain over the uncoded system with the same amount of diversity. Both EHD and EPD are functions of the channel covariance matrix but also depend on the codeword difference matrix \mathbf{D}_{ec} . Therefore a clever ST signal design is crucial for achieving diversity and coding gains in a MISO system even when employing optimal MLD at the receiver. This fact was first recognized in [255, 256] and later used in [254] to formulate the design criteria for STCs over fading channels. The maximization of the minimum EHD, coined the *rank* criterion on slow fading channels and the *distance* criterion on fast fading channels, was identified as the primary important STC design criterion [254]. The maximization of the minimum EPD, termed the *determinant* criterion on slow fading channels and *product* criterion on fast fading channels, was established as a secondary importance STC design criterion [254]. The rank and the determinant design criteria were showed therein to be valid also for spatially correlated Rayleigh fading. The effect of spatial fading correlation was further examined in [257, 258, 259]. The STC design metrics for arbitrary block fading were studied in [260] based on the pairwise error probability conditioned by the worst case fading realization.

For $M > 1$, the system model in (2.2) can be easily extended to $\mathbf{r} = \sqrt{E_s} \mathbf{D}_{c,M} \boldsymbol{\alpha} + \boldsymbol{\eta}$ by defining an $L \times MNL$ block matrix $\mathbf{D}_{c,M} = [\mathbf{D}_c, \dots, \mathbf{D}_c]$ and introducing $\mathbf{r} = [\mathbf{r}_1^{\text{T}}, \dots, \mathbf{r}_M^{\text{T}}]^{\text{T}}$, $\boldsymbol{\alpha} = [\boldsymbol{\alpha}_1^{\text{T}}, \dots, \boldsymbol{\alpha}_M^{\text{T}}]^{\text{T}}$, $\boldsymbol{\eta} = [\boldsymbol{\eta}_1^{\text{T}}, \dots, \boldsymbol{\eta}_M^{\text{T}}]^{\text{T}}$. The PEP is still given by (2.4) with $\mathbf{C}_{s,1}$ being replaced by $\mathbf{C}_{s,M}$. For the multiple receive antenna AWGN case, components of $\boldsymbol{\alpha}$ are constant and all ones. The covariance matrix of a channel \mathbf{C}_{α} becomes an all ones matrix which again reduces the SM to a unit rank matrix, i.e., $\Delta_{\text{H}}(\mathbf{C}_{s,M}) = 1$. The only non-zero eigenvalue of $\mathbf{C}_{s,M}$ as the Euclidean distance between $\mathbf{D}_{e,M}$ and $\mathbf{D}_{c,M}$ increases to $\Delta_{\text{P}}(\mathbf{C}_{s,M}) = M \Delta_{\text{P}}(\mathbf{C}_{s,1})$

which can be seen as a gain from repetition coding. For multiple spatially uncorrelated receive antennas, the new SM becomes $\mathbf{C}_{s,M} = \text{diag}[\mathbf{C}_{s,1}, \dots, \mathbf{C}_{s,1}]$. This effectively increases by M the multiplicity of all eigenvalues in the asymptotic bound in (2.4), i.e., $\Delta_H(\mathbf{C}_{s,M}) = M\Delta_H(\mathbf{C}_{s,1})$. Unlike transmit antenna diversity that requires a special signal design, receive antenna diversity results in a straightforward M -fold increase in diversity order. Notice that EPD remains unchanged, i.e., $\Delta_P(\mathbf{C}_{s,M}) = \Delta_P(\mathbf{C}_{s,1})$.

In [261] it was further shown that for reasonably large diversity order, i.e., $\Delta_H(\mathbf{C}_{s,M}) \geq 4$, a MIMO channel converges to a Gaussian channel, i.e., the type of fading that a transmitted signal experiences does not have an impact on the performance. In such a case the performance is determined by the squared Euclidean distance $\Delta_P(\mathbf{C}_{s,1awgn})$ of the code as shown in (2.5), the maximization of which, denoted as the *trace* criterion, was introduced in [261] as the secondary importance design criterion after the primary rank or distance criterion. A similar conclusion on the importance of the code squared Euclidean distance over quasi-static fading channels for systems with a large number of receive antennas but also those operating in the low SNR region was given in [262, 263] where it was argued that ST coding optimization based on the PEP bound in (2.4), asymptotically tight only for high SNR, may not be always adequate. In the moderate SNR region, the EPD was defined as the determinant of the sum of an identity matrix and the eigenvalue-equivalent SM matrix in (2.7) [262]. The equal eigenvalue criterion was introduced independently in [264, 265] in a context of the determinant criterion and optimal coding gain, arguing that the maximization of the minimum code squared Euclidean distance renders eigenvalues of the SM to be equal, which maximizes the minimum EPD.

The PEP is the basic building block for the derivation of the union bound (UB), an upper bound to the error probability of a channel coding scheme given as

$$P_{\text{UB}} = \sum_{\mathcal{D}} H(\Delta_H, \Delta_P) P(\Delta_H, \Delta_P) \quad (2.10)$$

where $H(\Delta_H, \Delta_P)$ denotes the multiplicities in a two dimensional code's DS, i.e., the average number of error events with the EHD and the EPD equal to Δ_H and Δ_P , respectively. The EHD and the EPD are commonly referred to as error coefficients, and also as error exponents. $P(\Delta_H, \Delta_P)$ denotes the PEP in (2.4) as a function of the error coefficients. The set \mathcal{D} includes all distinct $\langle \Delta_H, \Delta_P \rangle$ pairs in the two-dimensional DS of a code.

2.2.2 Space-time coded modulation

Designed for simultaneous diversity and coding gains, different proposals for STCMs in the literature are mainly distinguished based on single antenna coded modulations, i.e., TrCM, multiple TrCM, multi-level coded modulation and BICM that they were extended from. Owing to its integrated trellis coding and higher order modulation design with the redundancy expansion in both signal and antenna space,

space-time trellis codes (STTrCs) [254], also referred to as ST TrCM, can be seen as a generalization of the TrCM to multi-antenna systems. STTrCs evolved from the combined transmit delay diversity (DD) and receive MLD, originally introduced for two transmit antennas in [266, 267] and further generalized to an arbitrary number of transmit antennas in [268, 269]. Comparing the statistical distribution of the minimum Euclidean distance for the DD to that of the matched filter bound authors in [268] showed that the DD achieves the diversity gain within 0.1 dB of a system with an equivalent number of receive antennas. The matched filter bound is a bound on the performance with an optimal receiver that fully compensates for the ISI and interference from all other signals, i.e., the lower bound on performance with an ideal equalizer. In [268] the outputs of a rate $1/N$ repetition encoder after being split into N parallel data sub-streams were transmitted simultaneously over N transmit antennas introducing one symbol delay between antennas. Answering the fundamental question as to whether replacing a rate $1/N$ repetition code with a specially designed channel code of the same rate could improve the performance over the DD, authors in [254, 270, 271] introduced STTrCs as a new paradigm for bandwidth and power efficient signalling over MIMO fading channels. Handcrafted low constraint-length 4-, 8-, 16-, 32-, 64-state STTrCs for two transmit antenna and QPSK, 8PSK, and 16QAM modulation in [254] were optimized upon the rank and determinant criteria. Offering the best possible trade-off between constellation size, data rate, diversity gain, and trellis complexity, STTrCs from [254] have been demonstrated to perform reasonably close to the outage capacity.

A more extensive computer search resulted in improved versions of the low constraint-length $N = 2$ QPSK codes in [272] and $N = 2, 3, 5$ BPSK codes and $N = 2$ QPSK codes in [273]. Some of the codes in [272] and [273] had the same EPD despite the different generators, which indicated that at least for $N = 2$ there is a multiplicity of optimal codes with respect to the minimum PEP. The “zero symmetry” as the sufficient, though not the necessary, condition for full transmit diversity over quasi-static fading channels, commonly conditioned by $\min(\Delta_H) = N$, was introduced in [273] as a generalization of the similar design rules in [254]. The zero symmetry considerably constrained the computer searches for good STTrCs. The DD was also proven to use the fewest possible states for achieving full diversity. The rank and trace criterion were used for STTrC optimization over quasi-static fading channels for two transmit antennas in [274, 261, 275, 276, 265] and for three and four transmit antennas in [277, 278]. The optimization of STTrCs over quasi-static fading channels for the case of a large number of receive antennas or for low SNR values was based just on the trace criterion in [262]. For moderate SNR values, the modified determinant criterion was applied. The systematic STTrC design for an arbitrary number of transmit antennas was further studied in [279] based on the rank and determinant criteria. The low constraint-length STTrC optimization for fast fading channels based on the distance and product criterion was considered in [280, 281, 282, 283, 284].

The ST coding optimization based on the minimal PEP with the MLD as well as the evaluation of the UB in (2.10) are greatly simplified when the uniform DS with respect to both the EHD and the EPD is guaranteed *a priori* [273]. In such cases, it is sufficient to consider only the particular codeword for \mathbf{D}_c , i.e., the all-

zero codeword and vary only \mathbf{D}_e when calculating all possible codeword difference matrices \mathbf{D}_{ec} for the EHD and EPD. Geometrical uniformity (GU) is one of the most restrictive types of symmetry that provides the uniform DS [285, 254, 273]. However it was shown in [273] that a feed-forward TrCM that is GU with respect to the EPD and uses PSK modulation achieves at most one level of diversity. Although some less restrictive condition for the uniform DS like linearity can be used to simplify evaluation of the DS with respect to EHD [286], similar solutions for the DS with respect to EPD are not appealing. Based on the PEP in (2.4), the UB for the general class of geometrically non-uniform (GNU) STTrCs was calculated in [287] applying the GA from [285] and in [288] through the simplified code transfer function from [289]. Different views on the PEP were further given in [290, 291, 292, 293, 294]. However, evaluating the UB, papers [290, 291, 292] assumed the uniform DS for the considered STTrCs. The efficiently calculable necessary and sufficient conditions for STC codeword difference matrices to achieve full diversity over quasi-static fading were established in [295, 296]. Upper and lower bounds on the minimum EPD over quasi-static fading channels as a function of the error event length as well as the average values of upper and lower bounds for the given error event length averaged over all possible starting states, ending states and inputs were also established therein and used in [297] for $N = 2, 3, 4$ BPSK and QPSK STTrC optimization.

For a transmission rate of K bps/Hz where each symbol transmitted from one of N spatially uncorrelated antennas belongs to a complex constellation of size 2^Z , in a majority of the above references a model for STTrC optimization assumed binary inputs and binary feed-forward shift registers with generator polynomials defined over \mathbb{Z}_{2^Z} , the ring of integers modulo 2^Z . For most STTrCs in the literature, the condition $Z = K$ holds. Therefore to preserve the transmission rate, the expansion in multi-antenna TrCM is performed only in the antenna space. In [283], the trellis was fully defined over \mathbb{Z}_{2^K} with the input bits transferred to \mathbb{Z}_{2^K} integers through a Gray mapping prior to entering the encoder. In [275] the STTrC was fully defined over \mathbb{Z}_2 and the encoder output bits were transferred to \mathbb{Z}_{2^K} through either natural or Gray mapping. In all the above cases, the encoder integer outputs from \mathbb{Z}_{2^K} were then modulated to a complex constellation of size 2^K . The STC design criteria from Subsection 2.2.1 are then applied to those baseband complex constellation signals, which is difficult to relate to traditional code designs over finite fields and rings. Tending to bridge this discrepancy, paper [286] introduced the binary rank criterion for BPSK codes and \mathbb{Z}_4 QPSK codes that considerably simplified the construction of full spatial diversity codes over quasi-static fading channels. The algebraic STC design for BPSK and QPSK modulation based on the established binary rank criteria was performed in a companion paper [298]. The binary rank criterion for 2^{2K} QAM codes was further studied in [299] and for block fading channels in [300]. The similar gauge for the determinant criterion and the EPD in general does not exist.

The design of robust STTrCs for an arbitrary fading Doppler frequency was addressed in [254] where the notion of the *smart* and *greedy* codes was introduced to denote codes that are optimized upon the hybrid distance/rank and product/determinant criteria. Based on the concatenation of an outer high rate Reed-Solomon code and an inner multiple ST TrCM, the smart and greedy codes

resulted in robust and power efficient MIMO signalling schemes, though with rates no greater than in current single antenna systems. The extension of multiple TrCM to MIMO systems was further studied in [301, 279]. The extension of multi-level coded modulation to MIMO systems applying sub-optimal multistage decoding was considered in [254, 302]. The multi-antenna BICM was devised in [303, 304] and with iterative MIMO equalization and decoding in [305, 306, 307]. Multi-antenna block coded modulation was considered in [254, 308]. A pragmatic approach to STC design where of-the-shelf single antenna convolutional codes were adapted for multi-antenna transmission was studied in [309, 292] and further in [310] based on algebraic overlays and binary rank criterion [286]. The STTrC design for nonlinear constant-envelope modulation was studied in [311]. The performance evaluation of STTrCs with different types of equalizers at a receiver for the SC based systems over frequency selective fading channels was investigated in [271, 312, 313, 314, 315, 316] including iterative MIMO equalization and STTrC decoding in [317, 318]. The optimal STTrC design in the presence of ISI at the receiver was addressed in [319, 320, 321]. The impact of CSI errors to the performance of STTrCs was inspected in [271] and iterative CSI estimation and STC decoding in [322, 323, 324, 325]. The analysis of the probability of an erroneous un-coded modulated transmission over MIMO channels with maximum-likelihood detection and imperfect CSI at the receiver was presented in [326].

2.2.3 Space-time block codes

Owing to the linear matrix pre-coding at the transmitter that reduces the optimal MLD at the receiver to simple linear combining, STBCs [327, 328, 329, 330] represent an attractive open loop transmit diversity scheme that satisfies the rank criterion for full transmit diversity over quasi-static fading channels but offers no coding gain over uncoded system with the same diversity order. The transmission period L to which the quasi-static nature of fading refers to here is rather short, i.e., typically $L \leq 2N$ is satisfied. A simple transmit diversity scheme for two transmit antennas originally introduced in [331] and in a slightly modified form standardized for third generation cellular systems [332], motivated authors in [327, 328] to generalize such a signalling approach to an arbitrary number of transmit antennas. The STBCs in combination with maximum ratio combining receive diversity, as common to the majority of transmit diversity schemes, transforms a MIMO fading channel into a SISO channel with characteristics desirably close to Gaussian. Numerous papers have studied the performance and optimization of different single antenna coded modulations employed over such an equivalent SISO channel [333, 334, 309, 335, 336, 337, 338, 339, 340, 341, 342, 343, 344, 345, 346, 347].

The STBCs' underlying mathematical framework of orthogonal designs poses restrictions in terms of maximum achievable rates when complex signal constellations are used. The schemes for more than two transmit antennas have a drawback of decreased rate as compared to single transmit antenna systems. To preserve the rate in such a case, the diversity order must be compromised with the code orthogo-

nality, i.e., the level of self-interference induced [348, 349]. Additional parameters to trade-off for good performance are given by the possibility to puncture a “mother” code and change the modulation level in the employed single antenna coded modulation [350]. The adaptation of STBCs to SC systems in frequency selective fading channels was studied in [351, 352, 353, 354, 355]. It was further shown in [313] that in frequency selective fading channels with $L_M + 1$ taps the diversity order exhibited by the STBC’s matched filter bound is $2(L_M + 1)$ while that of the DD is $L_M + 2$. The channel estimation for STBCs was studied in [356].

2.2.4 Layered space-time coding architectures

The complexity of MLD decoding increases exponentially with the transmission rate K (bps/Hz) and the number of transmit antennas N . Despite the recent efforts to reduce such complexity by sub-optimal combining [357, 358], the optimal ST coding designs for full rate MIMO transmission, commonly conditioned by $K = N$, are mainly constrained to two transmit antennas.

Inspired by the lower bound on MIMO channel capacity (1.5) authors in [38] proposed the Bell Labs Layered Space-Time (BLAST) architecture as a reduced complexity, pragmatic method for achieving high bandwidth efficiencies in systems with a large number of transmit and receive antennas. The introduction of BLAST motivated the vast interest for design of different layered space-time (LST) coding architectures that combine spatial multiplexing at the transmitter with different sub-optimal linear and non-linear ST detectors at the receiver to assemble classical single antenna channel codes to MIMO systems. In spatial multiplexing a single data bit stream is demultiplexed through serial-to-parallel conversion into N data sub-streams, commonly denoted as data layers that are independently interleaved, modulated and transmitted simultaneously from N uncorrelated transmit antennas. In the case of horizontally-LST coding each layer is transmitted only from its own corresponding antenna. The preferred approach from [38], introduced as diagonally-LST coding, assumed an additional cyclic permutation of layers among the transmit antennas.

The sub-optimal non-linear detection proposed in [38] assumes successive zero forcing (ZF) or minimum mean square error (MMSE) based interference suppression of layers that are not yet detected combined with decision directed interference cancellation of those layers previously detected. Since the linear spatial filtering of the desired layer out of n interfering layers in the n th step of detection, $n = 1, \dots, N$, requires $n - 1$ receive antennas, the order of receive diversity increases successively from $(M - N) + 1$ to M just like the diversity order in the lower bound on MIMO capacity in (1.5). For SC based systems operating in frequency selective fading channels, temporal equalization can be added to linear or decision feedback interfaces to combat ISI at the receiver. Different non-linear receivers for LST codes were further studied in [359, 360, 361, 362, 363, 364, 365, 366, 367, 368, 369, 370]. Spatial multiplexing systems with linear receiver interfaces were examined in [371, 372, 263] and with reduced complexity MLD in [373, 374]. Some of the above papers

also include PEP analysis for sub-optimal linear and non-linear detection.

The LST codes can be implemented as horizontally-coded or vertically-coded distinguished by the position of the serial-to-parallel converter before or after a channel encoder, respectively [375, 376, 377, 378]. The horizontally-coded LST code therefore employs a separate encoder for each of N data layers while in the case of vertically-coded LST code outputs of a single encoder are de-multiplexed to N data layers. The hybrid horizontal-vertical coding that commonly results in a reduced transmission rate was also considered in [375]. A non-linear detector processes the received signal along both the spatial and temporal domain in a manner determined by the employed type of encoding and layering. The horizontally-coded horizontally-LST coding offers improved decoded based decision directed interference cancellation since in each step of detection, in between the interference suppression and the interference cancellation, decoding of a given layer can take place to reduce error propagation. For the vertically-coded horizontally-LST codes and vertically-coded diagonally-LST codes decoding can start only after all the layers have been detected. Therefore, interference cancellation is based on row decisions though schemes are expected to benefit from the averaged SINR over successive layers, i.e., spatial interleaving. For the horizontally-coded diagonally-LST code to benefit from decoder aided interference cancellation, the codewords must be short enough to span not more than a diagonal of a transmission matrix which may considerably limit performance [379]. Another possibility applicable also for vertically-coded diagonally-LST codes is to employ Viterbi trace-back [380] or per-survivor processing [381] as in [382, 383].

The LST codes in general require $M \geq N$ and the dominant diversity order is $M - N + 1$ experienced in the first step of detection. The MLD aided detection of the first few layers was considered in [384] as a possible way to overcome this problem by adding some complexity. To retrieve full receiver diversity and further improve the performance for different types of coding and layering the iterative detection and decoding is commonly applied [375, 385, 376, 386, 383, 387]. After the first stage of detection and decoding that comprises both the interference suppression and decision directed interference cancellation, the successive stages employ only the interference cancellation. Hard or soft decisions from the previous stages are used to cancel the interfering layers enabling the full number of receive antennas to be utilized for diversity reception.

A generalization of LST coding introduced as ZF array processing in [388] and maximum SNR array processing in [389] proposed a pair-wise partitioning of antennas at the transmitter for combined MIMO signal processing and ST decoding at the receiver. Unlike LST codes where spatially multiplexed signals with equal average transmitted power were detected in order of decreased post-detection SNR, i.e., post-ordered detection, the order of detection in [388] and [389] followed the ad-hoc unequal geometrical or arithmetical power allocation among different pairs of transmitting signals respectively, i.e., pre-ordered detection. In [390] it was further shown that post-ordered detection can substantially improve the performance of ZF based array processing. Optimal power allocation for generalized LST coding was studied in [391]. Unlike the classical horizontally-coded LST codes and vertically-coded LST codes where powerful TuCs were employed as component codes, papers

[388, 389, 390, 391] considered only the horizontally low-constraint length ST trellis coded systems and the single user narrow-band case. Low complexity hard decision iterative detection and decoding for generalized LST coding was studied in [392, 390].

A high-rate linear dispersion pre-coding that subsumes both LST codes and STBCs as special cases was introduced in [393] and further studied in [394, 395, 396, 397]. The $N \times L$ ST transmission matrices are obtained as linear combinations of unitary $N \times L$ basis matrices with the expansion coefficients being the scalar complex-valued data symbols. The LST code seizes $L = 1$ and both the LST code and the STBC assume that expansion coefficients are components of N data layers in each time instant. The unitary basis matrices for linear spatial-temporal data dispersion were chosen to maximize the mutual information between the transmitted and received data symbols. Examining the available degrees of freedom for transmission it was concluded that the maximal mutual information achievable with LST coding is equal to the full multi-antenna channel capacity while for the STBCs this is true only in the special case of $M = 1$. Much the same conclusions on the optimality of LST coding with respect to attainable MIMO capacity were proven in [398] based on the matched filter bound. Although similar capacity analysis for ST coded modulations in general are not available, schemes designed to minimize PEP with assumed MLD, i.e., ST coded modulation and STBC, were characterized as optimal with respect to link reliability while the LST code was identified as optimal with respect to channel capacity. As capacity maximization does not guarantee good performance in terms of error probability, steps toward unified capacity and reliability optimization were made in [394, 395, 396]. Other recent work on LST coding include linear Walsh pre-coded LST codes in [399], threaded LST codes in [400] and wrapped LST codes in [401].

3 Scope of the thesis

This thesis concentrates on the design and analysis of STCs optimized for high bandwidth efficiency and transmission reliability under the assumption of no available CSI at the transmitter and optimal MLD with perfect CSI at the receiver. The several interesting open problems that motivated the work of this thesis are introduced in Section 3.1. The main contributions of the thesis are summarized in Section 3.2. The relation to closely related parallel work in space-time turbo coding is presented in Section 3.3.

3.1 Problem formulation

As seen from Subsection 2.2.2, high computational complexity constrained the truly exhaustive computer searches for good STCMs primarily to low constraint length STTrCs. Such codes were primarily devised to achieve the maximum transmit diversity gain. Due to their low memory order, optimization based on the secondary importance design criterion resulted in rather modest coding gains. Further performance improvements anticipated in Shannon's channel coding theorem by an increase in constraint lengths are hampered by the lack of systematic procedure for reducing the cardinality of the searched class of codes. The recent ad-hoc attempt to construct a large constraint length, 256-state STTrC in [402] resulted in a highly non-optimized brute force solution as examined in Papers IV and V.

As another disadvantage of the limited degree of freedom, the different low memory order STTrCs are almost exclusively constructed for either slow or fast fading channels. Therefore in the practical applications, characterized by extremely variable Doppler frequencies, they commonly fail to demonstrate much needed robustness. On the other hand, the main drawback of increased constraint lengths is the prohibitively large decoding complexity, which may increase exponentially if optimal maximum-likelihood decoding (MLD) is applied at the receiver. Therefore, robust STCMs with large equivalent memory orders structured to allow sub-optimal low complexity iterative decoding are needed. Furthermore, the state of the art in ST

coding design is almost exclusively concentrated around design criteria targeting the error coefficients, i.e., maximizing the minimum EHD and EPD. Such optimization does not take into account either the effect of pair-wise error events with the EHD and the EPD above the minimum nor the contribution of multiplicities to the UB in (2.10). As a result, different codes with the same minimum EHD and EPD sometimes resulted in different performance when compared through simulations.

3.2 Contribution of the thesis

To address the aforementioned open problems, Papers I and II proposed STTuCM as one of the earliest MIMO coding designs built on the well established intersection of three fundamental coding concepts: combining several codes by code concatenation; the random-like code design criterion; and that of sub-optimal iterative decoding. The systematic procedure for building an equivalent recursive space-time trellis code (Rec-STTrC) based on the trellis diagram of an arbitrary non-recursive STTrC was further introduced in Paper III and with slightly more comprehensive notation in Paper VI. Papers I and II also demonstrated the importance of recursive versus non-recursive STTrCs for interleaved multi-antenna code concatenations. While both parallel and serial concatenated STTuCMs have been introduced in Paper I, the main focus in the subsequent work has been placed on parallel code concatenation. Serial concatenated STTuCM from Paper I assumed low-constraint length inner Rec-STTrCs and outer binary convolutional codes, resulting in a signalling method with improved power efficiency but with a rate no greater than in single antenna systems. To preserve full transmission rate, parallel concatenated STTuCM employed punctured low constraint length Rec-STTrCs for CCs resulting in increased coding and diversity gains over a variety of block fading channels.

Papers IV, V, and VI studied the application of STTuCM to multi-antenna OFDM based broadband wireless networks. Combined generalized LST coding and STTuCM was advocated in Paper VII as a sub-optimal low-complexity scheme for achieving high bandwidth efficiencies employing an arbitrary number of transmit antennas. Although the considered signalling method is more general, Paper VII assumed a frequency selective WCDMA downlink channel for the application scenario. To further remove the complexity burden in future WCDMA mobile terminals, Paper VIII proposed orthogonalized spatial multiplexing as a combination of coded spatial multiplexing and WCDMA DD. Although some more advanced multiuser detection based receiver can be applied, Paper VIII considered a simple matched filter followed by the channel decoder.

For CCs in Papers I – VIII, the recursive versions of two transmit antenna QPSK, 8PSK, and 16QAM Tarokh et al. space-time trellis codes (Tarokh-STTrCs) from [254] were applied. Rather severe puncturing with no particular optimization of CCs resulted in destruction of rank properties of STTuCM. However, it was already noticed from simulations in Papers I and II, that by replacing one of the CCs with the original non-recursive Tarokh-STTrC, the resulting STTuCM manages to

preserve the full spatial diversity over quasi-static fading channels in the region of low to medium SNRs typically exhibited in practice. For block fading channels with $B > 1$, the configuration with both Rec-STTrCs is preferable due to significantly better performance.

The simulation results motivated the theoretical studies on DS interpretation and the UB performance of STTuCM over slow fading channels in Paper IX and fast fading channels in Paper X. Analysis confirmed the behavior seen in simulations of the above two recursive and non-fully recursive configurations over block fading channels. Revealing the similar effect of spectral thinning as in single antenna binary TuCs, the DS analysis gave good insight into the importance of multiplicities for ST coding design. To enable the analysis tractable, the information interleaver between CCs in parallel concatenation was assumed to be random with a uniform distribution resulting in the upper bound of the performance of MLD averaged over all different information interleavers. The modified design criteria for STCs that capture the joint effects of error coefficients and multiplicities in a two dimensional code's DS have been introduced in Papers XI and XII. Applied to STTuCM, such DS optimization produced a new set of two antenna QPSK CCs, which with no merits as a stand-alone STTrCs, resulted in a robust parallel concatenated ST coding scheme with improved performance over both slow and fast fading channels.

A recursive systematic form with a primitive equivalent feedback polynomial was assumed for CCs to assure good convergence of iterative decoding. Iterative decoding convergence analysis based on the Gaussian approximation of the extrinsic information was studied further in Paper XI to validate such assumptions. The introduced DS interpretation with respect to an arbitrary defined EHD and EPD is applicable to the general class of GNU CCs. The adopted transform domain model with generator polynomials enables the straightforward optimization of CCs for an arbitrary number of transmit antennas and modulation levels. The interesting special case of CC optimization for single antenna TuCMs over AWGN or fading channels is left for future work. With no constraints on the implemented information interleaving, the STTuCM constructed from the newly introduced recursive systematic space-time trellis codes achieved full spatial diversity over quasi-static fading channels. This condition is identified as the most restrictive one for robust performance over a variety of Doppler spreads. This leaves a great deal of freedom for information interleaving optimization, which is an interesting topic left for future work. Finally, the pros and cons of bit and symbol level processing with respect to the DS were discussed in Paper XII. From the above, the scope of the thesis is easily identified as a combination of turbo coding and ST coding.

3.3 Closely related parallel work

In parallel to the development of this thesis there have been other independent proposals in the literature for coherent ST coding schemes motivated by the turbo coding principle. Different parallel [403, 404, 405, 406, 407, 408] and serial [403, 409] concatenated space-time turbo codes can be mainly distinguished based on the

single antenna TuCMs they were augmented from.

The STTuCM proposed in this thesis employs recursive versions of STTrCs for CCs in parallel concatenation. This STTuCM and different ST turbo coding schemes studied in papers [403, 404, 405] can be characterized as generalizations of single antenna TuCM from [196] to multiple antenna systems. Papers [403, 404, 405] and accompanied papers [410, 411, 412, 413] considered mainly two transmit antenna BPSK, QPSK, and 8PSK constituent STTrCs. The main features distinguishing the approach proposed in this thesis compared to papers [403, 404, 405] will be more apparent after examining the system model in Section 4.1. Here we only outline that apart from different CCs, the scheme in [403] applied no puncturing, resulting in an ST TuC with reduced rate as compared to its CCs. Also, due to the structure of the information interleaver, schemes in [404, 405] were designed to operate on the symbol level while the STTuCM advocated in this thesis operates on the bit level. Also, no particular optimization for the resulting parallel concatenated coding scheme other than that regularly applied for CCs as stand-alone STTrCs was assumed in [403, 404, 405].

The ST turbo coding scheme suggested in [406] and further studied in [414, 415, 416] can be characterized as multiple transmit antenna extension of TuCM from [194]. The binary outputs of a classical single antenna TuC were interleaved and spatially multiplexed to a number of transmit antennas. In such a way, transmission layers are formed similar to vertically-coded horizontally-LST coding. Different spectral efficiencies are obtained by varying the TuC rate, the number of transmit antennas $N = 2, \dots, 8$, and the constellation size in the range of BPSK, QPSK, 8PSK, and 16QAM. At the receiver, the LLRs for each encoded bit were calculated by the soft output demodulator and after de-interleaving passed to the standard binary turbo decoder. Iterative demodulation and decoding was also considered for further performance improvement in [415]. Lacking any optimization, such a pragmatic approach to STCM did not guarantee full spatial diversity over quasi-static fading channels. However, due to its flexibility and improved performance over block fading channels, when $B > 1$, it attracted much attention in the literature. Since essentially any traditional single antenna channel code can be employed with the above system model, e.g., paper [417] considered block TuCs, the above separated coding and modulation scheme can be also characterized as a multi-antenna BICM. The spatial multiplexing related issues were further studied in [418]. A similar approach to ST turbo coding was considered in [408] where each of the BPSK outputs from a rate 1/2 (1/3) binary TuC was assigned to one of $N = 2$ ($N = 3$) transmit antennas. To prevent an all-one input bit sequence from destroying the rank property of a code, the information deinterleaving was added at the second (the third) transmit antenna. A computer search for the particular information interleaving realization that combined with the TuC generator polynomial satisfy binary rank criterion at the output of a ST TuC [286] was performed to secure full spatial diversity over quasi-static fading channels. Nevertheless, the transmission rate of the scheme was no higher than in single antenna systems.

An extension of single antenna TuCM from [197] to multi-antenna transmission was proposed in [407] and further studied in the companion papers [419, 420]. Similar to [197], during each trellis transition, the recursive systematic binary trellis

of the CC in parallel concatenation, adopting an even number of consecutive input bits denoted as input symbol, produces a number of unmodulated output bits. In each CC, half of the systematic bits are punctured and the remaining systematic and parity bits are mapped to a QPSK complex constellation. After being channel interleaved the two QPSK symbols from CCs are either transmitted directly, each from its own transmit antenna or with an optional multiplexer that alters the two transmit antennas every second time instant. At the receiver, the LLRs for each encoded bit were calculated by the soft output demodulator and passed to the corresponding symbol-by-symbol MAP decoder. Iterative demodulation and decoding was also considered therein. Referring to Section 2.1, the above scheme was designed to operate on the symbol level. Similar to [408], the computer search for particular information and channel interleaving realizations that combined with the CCs' generator polynomials satisfy the QAM binary rank criterion [299] at the output parallel concatenated scheme was performed to secure full spatial diversity over quasi-static fading channels. The asymptotically good de-correlation properties between the two CCs' outputs for long information interleavers were identified in [421] as the main attribute for its good performance. However, the presented approximate analytical performance evaluation based on the above correlation properties was rather loose. For performance improvement over slow frequency flat fading channels, the time-varying linear transformation at the transmitter and receiver, similar to the phase sweeping transmit diversity from [422] was considered in [423]. Likewise, in [424] the emphasis was put on the improved encoder and decoder processing.

The extension of serially concatenated single antenna TuCM [159] to multiple antenna transmission featuring different recursive inner STTrCs was apart from in Paper I, independently studied in [403, 425]. Non-recursive inner STTrCs were utilized in [426, 427] and similarly in [428] where iterative decoding was applied to a serial concatenation of an outer single antenna TuCM and an inner generalized DD scheme. In [429], the BICM was employed for the inner code in a serial concatenation. A different approach to serial concatenated multi-antenna TuCM, advocated for quasi-static fading channels was proposed in [409]. Prior to complex constellation mapping of size 2^K , each of N STTrC's integer outputs from \mathbb{Z}_{2^κ} were independently interleaved and encoded by a rate one inner code. Similar to single antenna TuCM from [163], such an accumulator defined here over the ring of integers \mathbb{Z}_{2^κ} , combined with interleaving and iterative decoding enabled considerable performance improvements without sacrificing the data rate. A similar scheme was further studied in [430]. The PEP of a serially concatenated STTuCM was interpreted in [425, 431] in a suitable form to underline the design guidelines for CCs and stress the importance of recursive inner codes for achieving interleaving gains. However, no performance analysis was performed therein.

The DS and UB performance analysis of multi-antenna TuCMs were in the current literature, apart from in Papers IX and X, also addressed in [404] over AWGN channels and in [410, 411] over quasi-static fading channels. In an analogy to a similar single antenna TuCM analysis from [236, 239], the authors in [404, 410, 411] added additional interleaving between encoding and modulation to enable tractable, transfer function based enumeration of the DS with respect to Hamming distance

in the CCs. However, such a radical discrepancy towards the simulation model, which utilized the parallel concatenated ST trellis coded modulations, is difficult to justify. A similar analysis was recently conducted in [432], though with a more closely related simulation system model from [415].

4 Summary of the original publications

This chapter briefly summarizes the main contributions of the thesis and gives guidelines for reading the appended original publications. The chosen sectioning reflects the various important aspects of STTuCM, which is newly introduced and studied in this thesis. The system model and design issues are summarized in Section 4.1. The performance evaluation under different application scenarios is reviewed in Section 4.2. The main contributions in terms of performance analysis are outlined in Section 4.3. The constituent code design and optimization based on DS and iterative decoding convergence is summarized in Section 4.4.

4.1 System model of space-time turbo coded modulation

The STTrCs in the literature are mostly designed in feed-forward convolutional form, i.e., they are not suitable for interleaved code concatenations. The trellis diagrams of the 4-, 8-, and 16-state Rec-STTrCs for $K = 2$ bps/Hz employing two transmit antennas and QPSK modulation are given in the appendices of Papers I and II. The two transmit antenna 8-state 8PSK Rec-STTrC for $K = 3$ bps/Hz and 16-state 16QAM Rec-STTrC for $K = 4$ bps/Hz are appended within Paper III. Notice that in all cases the condition $Z = K$ holds, i.e., the expansion is done only in the antenna space. Paper VI further systematizes the procedure used in Papers I, II, and III for building Rec-STTrCs. The method from Paper VI assures an infinite impulse response to the transfer function by reorganizing the input/output transitions in the trellis diagram of the original, non-recursive STTrC. The Rec-STTrCs from Papers II and III, which are utilized as CCs in the STTuCM throughout Papers I – VIII are built upon the Tarokh-STTrCs. The procedure is readily applicable to an arbitrary feed-forward STTrC.

Paper I introduced serial concatenated STTuCM. The transmitter employed an outer 4-state binary convolutional encoder concatenated through an information interleaver to the inner 4-state QPSK Rec-STTrC. The importance of recursive versus non-recursive inner STTrCs for large information interleaving lengths when

iterative decoding is implemented at the decoder is demonstrated in Paper I. Since this thesis mainly focuses on the parallel concatenation of constituent STTrCs, the system model of parallel concatenated STTuCM is examined here briefly. For more details on the encoder, information interleaving, and decoder, the reader is referred to Papers I and VI. Also, if not stated differently, the STTuCM will rigorously denote the parallel code concatenation in the sequel.

4.1.1 Encoder

Consider the block diagram of the STTuCM encoder in Fig. 4.1 built as the interleaved parallel concatenation of two CCs followed by puncturing and/or multiplexing. The input information frame $\mathbf{x} = [\mathbf{x}(1), \mathbf{x}(2), \dots, \mathbf{x}(L)]$ consisting at each time instant $l, l = 1, 2, \dots, L$, of a sequence of K bits $\mathbf{x}(l) = [x_1(l), x_2(l), \dots, x_K(l)]$ is first encoded by the first component encoder to produce a coded frame $\mathbf{c}^1 = [\mathbf{c}^1(1), \mathbf{c}^1(2), \dots, \mathbf{c}^1(L)]$. At each time instant l , the coded frame consists of N complex symbols $\mathbf{c}^1(l) = [c_1^1(l), c_2^1(l), \dots, c_N^1(l)]$ each belonging to 2^Z complex constellation with a unit average energy. Remember that for most of the STTrCs in the literature, the condition $Z = K$ holds, i.e., the expansion in multi-antenna TrCM is done only in the antenna space. The π_O/π_E interleaved version of the input information sequence is then encoded by the second component encoder to produce a coded frame $\mathbf{c}^2 = [\mathbf{c}^2(1), \mathbf{c}^2(2), \dots, \mathbf{c}^2(L)]$ of the same structure. Multiplexing assumes that at each time instant, only one of the component encoders has access to N transmit antennas. Without puncturing, the resulting rate of parallel concatenation is halved as compared to CCs. The coded STTuCM frame in such a case is denoted by $\mathbf{c} = [\mathbf{c}(1), \mathbf{c}(2), \dots, \mathbf{c}(2L)]$, $\mathbf{c}(l) = [c_1(l), c_2(l), \dots, c_N(l)]$ with $\mathbf{c}(2l-1) = [c_1^1(l), c_2^1(l), \dots, c_N^1(l)]$ and $\mathbf{c}(2l) = [c_1^2(l), c_2^2(l), \dots, c_N^2(l)]$. When puncturing is applied to preserve the overall rate, the resulting STTuCM coded frame becomes $\mathbf{c} = [\mathbf{c}(1), \mathbf{c}(2), \dots, \mathbf{c}(L)]$ with $\mathbf{c}(l) = \mathbf{c}^1(l)$ for l odd and $\mathbf{c}(l) = \mathbf{c}^2(l)$ for l even. The symbol $c_n(l)$, $n = 1, 2, \dots, N$ is associated to transmit antenna n during time instant l . Prior to transmission, the symbol stream on each transmit antenna is channel interleaved with the same symbol wise interleaving π_c .

4.1.2 Information interleaving

Without puncturing, the information interleaver π_O/π_E is modelled as a single pseudo-random bit-wise interleaving of length LK with no particular constraints. In the case of puncturing, the following restrictions hold. Let us introduce a union set operation $\mathcal{I}(l) = \cup\{(l-1)K+1, \dots, (l-1)K+K\}$ defined over the set of integers $\{l\}$. Consider the two unordered integer subsets \mathcal{I}_O and \mathcal{I}_E defined as $\mathcal{I}_O = \mathcal{I}(l)$ for l odd and $\mathcal{I}_E = \mathcal{I}(l)$ for l even with $\mathcal{I}_O \cap \mathcal{I}_E = \emptyset$, $\mathcal{I}_O \cup \mathcal{I}_E = \{1, \dots, KL\}$. Let

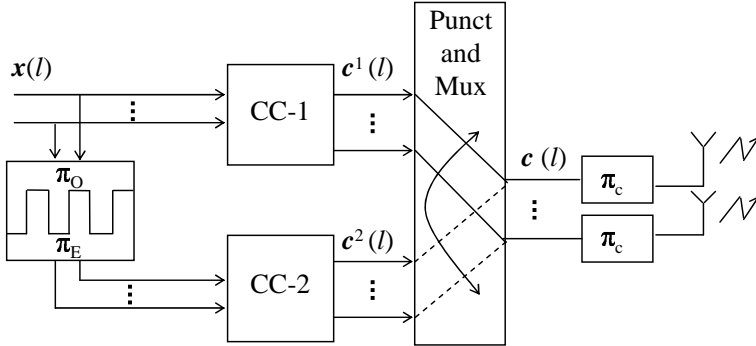

Fig. 4.1. Block diagram of the encoder.

i and the pseudo-random bit-wise permutation $\pi(i)$, denote the position of a bit in the input information frame before and after information interleaving, respectively. Function $\pi(i)$ is defined as a bijective, i.e., $\forall i \in \mathcal{I}_O \Rightarrow \pi_O(i) \in \mathcal{I}_O, \forall i \in \mathcal{I}_E \Rightarrow \pi_E(i) \in \mathcal{I}_E$. Therefore, interleaving consists of two independent pseudo-random bit-wise interleavers π_O and π_E for l odd and l even, respectively. Each π_O and π_E is of length $LK/2$. This assures in spite of puncturing equal error protection for all input information bits.

Apart from different CCs, the main feature that distinguishes the STTuCM proposed in this thesis from similar schemes studied in parallel in papers [403, 404, 405] is the structure of the information interleaver. In [403] no puncturing was considered, therefore a single pseudo-random bit-wise interleaver of length LK was applied. In [404] a single symbol-wise pseudo-random interleaver of length L was utilized. Due to additional symbol de-interleaving employed after the second CC, the input information bits were equally protected. However with no constrains imposed on the information interleaver, the second CC was non-uniformly punctured. In [405] the same symbol-wise odd–even information interleaver from [196] was adopted. Like the one implemented in [404], such an interleaver assures that the positions of the input bits in the input symbol $\mathbf{x}(l) = [x_1(l), x_2(l), \dots, x_K(l)]$ remain unchanged. The interleaver utilized in this thesis enables the mapping of input bits from the given even (odd) input symbol to any position of any even (odd) symbol.

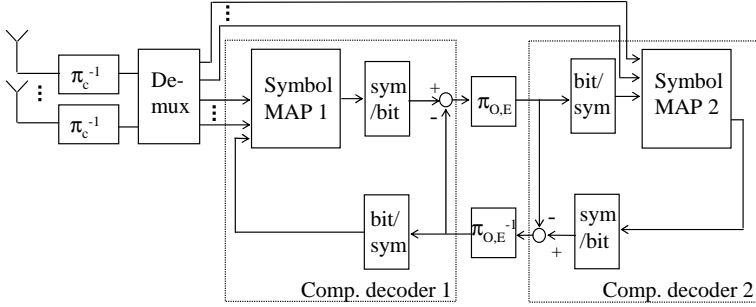

Fig. 4.2. Block diagram of the decoder.

4.1.3 Decoder

The block diagram of an STTuCM decoder is depicted in Fig. 4.2. Prior to iterative decoding, channel de-interleaving and received signal de-multiplexing is undertaken. In the case of puncturing, the erasures in the de-multiplexed signals are filled with zeros. The component codes are decoded by symbol-by-symbol MAP decoders. Due to assumed pseudo-random bit-wise information interleaving, additional symbol-to-bit and bit-to-symbol reliability transforms are applied so the exchange of extrinsic information between the two component decoders during iterative decoding is done on the bit level. Therefore the scheme designed and studied in this thesis operates on the bit level. When symbol-wise information interleaving is employed, as in [404, 405], the exchange of extrinsic information can be done directly on the symbol level. Therefore symbol-to-bit and bit-to-symbol reliability transforms are avoided and the resulting scheme operates on the symbol level. For more details on the component MAP decoders, symbol-to-bit and bit-to-symbol reliability transforms, and iterative decoding operating on the bit and symbol level the reader is referred to Paper VI.

4.2 Application scenarios

This section summarizes the application of the newly introduced method for building Rec-STTrCs and parallel concatenated STTuCM applied to Tarokh-STTrCs under narrowband frequency flat fading channels in Subsection 4.2.1 and for broadband OFDM wireless local area networks in Subsection 4.2.2. An application including some novel transceiver designs for WCDMA systems is summarized in Subsection 4.2.3.

4.2.1 Narrowband frequency flat fading channels

Papers I, II, III, and VI considered the application of STTuCM under the frequency flat fading channel model in (2.1). Block fading was assumed with the number of independent fading realizations per transmission frame B taking values from $B \in \{1, 2, 4, L\}$. For $B = 1$, the channel is denoted as quasi-static or slow, while the $B = L$ case, referred to as fast fading, represents the artificial case of an ideally channel interleaved system. The block fading model is in general suitable for fading channels in which a certain block of adjacent transmitted symbols are affected by highly correlated fading path gains. The length of the block may be considered as a first approximation of the channel's coherence time for SC systems or the channel's coherence bandwidth in MC systems. Since the MC case is covered independently in the next subsection, the results reviewed in this subsection illustrate the performance of TDMA systems, like GSM, IS-136, or enhanced data rates for GSM evolution (EDGE). The EDGE system relies on bandwidth efficient 8PSK modulation but has adopted the same underlying GSM frame structure where transmitted data is organized into 4 or 8 bursts and where optional frequency hopping between bursts is included in the standard. Papers I and II consider QPSK modulation while in Papers III and VI the study cases are extended to 8PSK and 16QAM modulation.

Paper II demonstrates the importance of Rec-STTrCs for the good performance of parallel concatenated STTuCM. Examining the slopes and horizontal shifts of the simulation curves, it becomes obvious that large diversity and coding gains can be achieved with this newly introduced signalling method without sacrificing data rate. A quite severe puncturing with no particular optimization of CCs resulted in destroyed rank properties of the STTuCM over quasi-static fading channels. However, it was already noticed from simulations in Papers I and II that the non-fully recursive configuration, built by replacing one of the CCs with the original non-recursive Tarokh-STTrC, preserves full spatial diversity over quasi-static fading channels in the low-to-medium SNR region, typically exhibited in practice. Already for $B > 1$, the configuration with both Rec-STTrCs was found to be preferable due to significantly better performance. Such behavior was initially attributed to the fact that both CCs in the non-fully recursive STTuCM were terminated at the end of the information frame while in the fully recursive STTuCM the second CC was left open. The true reason for the diverse behavior of the above two configurations over quasi-static and fast fading channels was unveiled in Papers IX, X, and XII by studying the rank deficient parts in the DS and its detrimental effects on UB performance. For the sake of fair comparison with low-constraint STTrCs, whose frame error rate (FER) performance severely deteriorates with increased frame sizes, Papers II, III, and VI assumed $LK = 130$. Papers I and XII further demonstrated that considerable performance improvement of STTuCM, directly proportional to B , can be achieved by increasing its frame size.

4.2.2 *Broadband OFDM based wireless local area networks*

To calculate the capacity of a frequency-selective fading channel, Shannon sliced the considered bandwidth into infinitesimal frequency flat sub-bands, inspiring the capacity approaching signalling strategy [44]. In OFDM, sub-bands remain mutually orthogonal despite their spectral overlapping. In the limit case of a large number of sub-carriers, the total occupied bandwidth is reduced by half compared to classical FDM systems. Due to its bandwidth efficiency and suitability for high data rates, OFDM has been chosen as a modulation scheme for physical layer in several wireless standards and system proposals, e.g., digital audio and video broadcasting (DAB, DVB) in Europe and the three broadband WLANs, European Hiperlan/2, American IEEE 802.11a, and Japanese MMAC [433].

The combined channel coding and interleaving across both adjacent sub-carriers and consecutive OFDM symbols is an efficient method for capturing the available frequency and temporal selectivity in a channel [434]. Adding multiple uncorrelated receive antennas in combination with maximum ratio combining, equal gain combining or selection combining on individual sub-carriers, commonly denoted as narrowband combining or on entire OFDM symbols, also known as wideband combining, provides additional spatial diversity in a straightforward manner. To move the complexity burden from MSs, a number of transmit diversity schemes for multi-antenna OFDM have been proposed and studied recently. Assigning different clusters of sub-carriers in an OFDM symbol to different transmit antennas, the inherent orthogonality between sub-carriers was exploited to separate multi-antenna transmissions at the receiver in [435, 436, 437]. The artificially increased multipath propagation obtained by applying the DD to OFDM systems was studied in [438]. A similar effect acquired by introducing a transmit antenna specific phase shift prior to OFDM modulation was considered in [439, 440, 441]. The permutation transmit antenna diversity combined with an MMSE receiver was studied in [438]. The above OFDM transmit diversity methods, as seen by single antenna channel codes employed therein, commonly transform an MISO channel into an equivalent SISO channel with increased frequency selectivity. The STBC as a unique transmit diversity scheme that can be applied for MIMO-OFDM over multi-antenna and, consecutive OFDM symbols or adjacent sub-carriers, was considered in [442, 443, 444, 445, 446, 447, 448].

Authors in [449] were among the first to propose simultaneous coding across multiple transmit antennas and OFDM tones, so called space-frequency (SF) coding. An outer high rate Reed-Solomon code was concatenated with an inner 16-state Tarokh-STTrC, optimized for frequency flat quasi-static fading channels. Nevertheless, the proposed scheme resulted in considerable bandwidth and power efficiency gains compared to the Reed-Solomon coded clustered OFDM transmit diversity from [435]. Examining the PEP of the SF coded systems, it was further concluded in [444] and independently in [402] that the maximum achievable diversity order in multi-antenna frequency-selective fading channels is bounded by NML_M , i.e., the product of the number of transmit antennas, the number of receive antennas, and the number of discrete multipaths. Based on the design criteria for SF codes derived in [444] and the design rules established in [450], some preliminary SF code

designs were recently presented in [451]. Such linear SF block codes, designed to achieve the full SF diversity in SF channels, still suffer from decreased data rates as compared to SISO systems in spite of the large constellation sizes they exercise.

In [444], it was further argued that STCs designed for fast fading channels, although not-necessarily being optimal in an SF setting, are expected to achieve a certain order of SF diversity. Motivated by the general relation between the code's EHD and the achievable diversity gain, authors in [402] adapted large constraint length TCMs to MIMO-OFDM. A class of rate 2/3 8PSK TCM, optimized for large EHD over single antenna fast fading channels was transformed into a rate 2/4 QPSK SF code for two transmit antennas. Splitting the original 8PSK mapping into two QPSK mappings, one for each transmit antenna, preserved the code's EHD. The sub-optimality of such an approach that does not account for the spatial diversity induced increase in the EHD, i.e., the rank of the MIMO SM in 2.3, was revealed in Paper IV. In their companion paper [452], authors recently considered the SF interpretation of the multi-antenna turbo coded modulation from [415] with the binary single antenna TuC being replaced by a Low Density Parity Check code. Presuming perfect frame and sample clock synchronization between the transmitter and receiver, the space-frequency representation of a MIMO-OFDM system can be directly plugged into the system model in (2.1) with coefficients $\alpha_{mn}(n_s)$ modelling the fading samples on sub-carrier n_s , instead of time instant l .

Stimulated by the largely increased diversity and coding gains exhibited over different narrowband block fading channels, Papers IV, V, and VI applied STTuCM over the SF domain. The coded frame was assumed to cover multiple successive OFDM symbols, which in general gave rise to simultaneous space, frequency, and time coding. Nevertheless, owing to low mobility and delay constraint assumptions valid for most current wireless systems, the frequency domain representation of multipath fading was modelled as quasi-static during one coded frame. Paper V utilized the MIMO-OFDM system parameters from [449, 402] and evaluated the performance over a two-path equal power channel. Papers IV and VI extended the study by adopting the physical layer parameters from the Hiperlan/2 and IEEE 802.11a WLAN standards and considered some specific ETSI-BRAN broadband wireless channels. A simple way of combining SF coding with OFDM DD for the artificially increased frequency selectivity of MIMO channels was proposed in Paper V and further studied in Paper IV. The STTuCM designed for 2bps/Hz with 2 transmit antennas and QPSK modulation utilized an additional 2 transmit antennas for DD in Paper V. Similarly, the sub-optimal, low complexity method for bandwidth efficient SF coding over 4 transmit antennas was considered in Paper IV where STTuCM for 4bps/Hz with 2 transmit antennas and 16QAM modulation was combined with DD. In summary, the STTuCM applied over multi-antennas and OFDM tones was concluded to perform within 2.5 dB of outage capacity for a variety of practical OFDM constrained broadband MIMO channels.

The application of different low constraint-length STTrCs to the SF domain was recently considered in [453], and in [454] where the measured broadband MIMO spatially correlated channels were utilized. Paper [455] considered the design criteria for SF codes with the assumption of sub-carrier grouping at the transmitter. When applied as SF codes over frequency selective channels, the LST coding demands quite

involved sub-carrier based spatial filtering at the receiver [456, 457]. Paper [458] applied generalized LST coding to MIMO-OFDM. Each layer in a horizontally coded system employed the 16-state STTrC from [254] designed for 2 transmit antennas and quasi-static fading. A further study in [459, 460] included for comparison the 2 transmit antenna 16-state STTrCs from [295, 297] designed for quasi-static and fast fading. Papers [459, 460] also proposed some ad-hoc designed 16- and 256-state STTrCs for 4 transmit antennas and QPSK modulation that resulted in improved performance over SF domain.

The application of STTuCM to a MIMO-MC-CDMA downlink was recently studied in paper [461]. It is one of the first references to address the ambiguous receiver design problem for systems characterized by an interesting trade-off between space-frequency diversity and multiuser orthogonality.

4.2.3 Wideband code-division multiple-access systems

In CDMA systems diversity plays an important role since any improvement in power efficiency eventually increases the system's soft limited capacity. Supporting the recent standardization of third generation cellular systems and its harmonization by a number of standard bodies in Europe, the USA, and Japan [332], a large embodiment of research has been focused on transmit diversity for WCDMA systems [462, 463, 464, 465, 466, 467, 468, 469, 470, 471, 472, 339]. Apart from broad coverage and a large number of low data rate users, these systems are envisioned to provide high peak data rates to individual users and to concentrate large amounts of traffic in localized spots. The MIMO signal design for improved bandwidth efficiency therefore draws special attention from vendors and operators of the coming third generation cellular systems. The application of different STCs from Section 2.2 to MIMO WCDMA systems is straightforward and has been studied extensively in the literature. Some of the basic references include [473, 474, 475, 339, 476]. The application of STCs and serial concatenated STTuCM to S-UMTS systems was examined in [477].

The LST codes from Subsection 2.2.4 have been mainly employed under different horizontally and vertically coded architectures using powerful single antenna channel codes. The application scenario commonly assumed WCDMA systems over frequency selective fading channels. The generalized LST codes on the other hand, considered only horizontally low-constraint length ST trellis coded systems and the single user narrow-band case. Paper VII studied generalized LST coding for a MIMO WCDMA downlink over frequency selective Rayleigh fading channels. The STTuCM for 2 transmit antennas has been adapted for more than two transmit antennas by combining array processing and ST turbo decoding at the receiver. Performance was evaluated in the (4,4) MIMO case with QPSK modulation. Both horizontally and vertically coded systems have been considered. The maximum SINR post-ordering array processing was first introduced and showed to offer considerable performance gains compared to ZF post-ordered detection [390] and pre-ordered both maximum SINR [389] and ZF [388] array processing. The spatial

filtering, applied at the output of each finger in the RAKE receiver, was followed by a multipath combiner incorporated into the decoder's metric. The scheme is more generally applicable as a sub-optimal low-complexity MIMO signalling method for an arbitrary number of transmit antennas in narrowband and OFDM based broadband systems. An alternative way of post-ordered array processing for WCDMA systems was further introduced and denoted as group-wise BLAST. As in BLAST, [360] the sufficient statistics for detection were first collected by space-time multipath combining. The post-ordering ZF and MMSE based spatial filtering was then applied to the equivalent matrix system model by operating on its successive entries, the number of which being equal to the number of transmit antennas grouped into one transmission layer. The possibilities for further improvements with low complexity hard decision iterative interference cancellation and decoding were also demonstrated. Paper VII concluded that STTuCM applied to the horizontally coded generalized LST coding with MMSE based group-wise BLAST processing at the receiver offers improved performance compared to other considered LST coding architectures.

The application of delayed versions of the same spreading code to different individual transmit antennas was proposed in [478] and further analyzed in [479, 480, 481, 482] as a WCDMA DD scheme. Exploiting multiple transmit antennas for the same throughput as in single antenna systems, the above method increased the power efficiency and system capacity in CDMA systems by creating artificial frequency selectivity in indoor low delay spread environments. A similar effect was achieved by applying the outputs of a low-rate super-orthogonal TuC to different transmit antennas in [483]. To further remove the complexity burden in mobile terminals and to increase the throughput in MIMO WCDMA downlink systems over frequency selective Rayleigh fading channels, Paper VIII utilized the good correlation properties of Walsh-Hadamard spreading codes to separate spatially multiplexed transmit signals at the receiver. A delayed version of the same spreading code was applied to different individual transmit antennas or alternatively groups of transmit antennas. The two schemes were denoted as orthogonalized spatial multiplexing with a resolution of one or two, respectively. In the considered low mobility environments, serial-to-parallel conversion in combination with orthogonalized transmission from different uncorrelated transmit antennas served as a unique spatial interleaving to the employed powerful channel coding schemes, i.e., TuC and STTuCM. The newly introduced method preserved the allocated number of spreading codes and enabled simple detection utilizing a RAKE receiver. Since signals are already separated at the transmitter there were no restrictions in terms of the minimum required number of receive antennas. The diversity level of the system was proportional to the number of employed receive antennas. It was further shown that the number of antennas at the receiver is determined by the level of interference in the system and the desired system performance and is typically lower than that in LST coding architectures. The application of more advanced receivers for further improvement and/or reduction in the required number of receive antennas is left for future work. The somewhat similar schemes to orthogonalized spatial multiplexing with resolution one were studied in [484] applying Gold codes and in [485] where spatial multiplexing was combined with multi-code transmission at the

expense of a reduced number of available spreading codes.

4.3 Performance analysis

The theoretical analysis in this section is aimed at better understanding the reasons for the outstanding performance of STTuCM seen in simulations. The main contributions include the DS interpretation in Subsection 4.3.1, UB over slow and fast fading channels in Subsection 4.3.2, and the iterative decoding convergence analysis in Subsection 4.3.3.

4.3.1 Distance spectrum interpretation

The two-dimensional DS interpretation of the punctured full-rate STTuCM with respect to the EHD and EPD over quasi-static and fast fading channels was introduced in Papers IX and X, respectively. To enable a tractable analysis, both the odd and even bite-wise pseudo-random interleavers from Subsection 4.1.2 were assumed to have a uniform distribution resulting in the DS averaged over all possible interleaving realizations. For the given error event $\{\mathbf{c} \rightarrow \mathbf{e}\}$ over slow fading channels, the eigenvalue-equivalent SM in (2.7) can be decomposed as

$$\tilde{\mathbf{C}}_{s,1\text{slow}}(\mathbf{c}, \mathbf{e}) = \tilde{\mathbf{C}}_{s,1\text{slow}}(\mathbf{c}^1, \mathbf{e}^1) + \tilde{\mathbf{C}}_{s,1\text{slow}}(\mathbf{c}^2, \mathbf{e}^2) \quad (4.1)$$

with separated terms contributed from the error events $\{\mathbf{c}^1 \rightarrow \mathbf{e}^1\}$ and $\{\mathbf{c}^2 \rightarrow \mathbf{e}^2\}$, in the first and the second CC, respectively. In addition to the SM, each error event $\{\mathbf{c}^i \rightarrow \mathbf{e}^i\}$, $i = 1, 2$, in the i th CC is identified by an 2^K component Hamming distance vector between the information sequence \mathbf{x} and its erroneous counterpart $\hat{\mathbf{x}}$ related to coded sequences \mathbf{c}^i and \mathbf{e}^i , respectively. For $K = 2$ the components of the newly introduced Hamming distance vector enumerate the number of bit positions of type $\{x_k(l), \hat{x}_k(l)\} = \{0, 1\}$ and type $\{x_k(l), \hat{x}_k(l)\} = \{1, 0\}$ in the two information interleavers. The sum over the components of the Hamming distance vector is naturally equal to the Hamming distance between \mathbf{x} and $\hat{\mathbf{x}}$. The multiplicity of the SM in (4.1) has been obtained as a product of multiplicities of the two de-multiplexed error events averaged by the probability of their joint occurrence. Since the two CCs share the same information error event $\{\mathbf{x} \rightarrow \hat{\mathbf{x}}\}$, only the error events $\{\mathbf{c}^1 \rightarrow \mathbf{e}^1\}$ and $\{\mathbf{c}^2 \rightarrow \mathbf{e}^2\}$ with the same value of the Hamming distance vector can be statistically combined. The DS of STTuCM with respect to all the different Hamming distance vectors and the SMs has been evaluated first. For each SM in such a DS, the rank and the geometric mean of its eigenvalues have been calculated to get the DS of STTuCM with respect to the Hamming distance vector, the EHD, and the EPD. The DS interpretation of STTuCM over AWGN channels can be easily also evaluated at this point since the Euclidean distance between \mathbf{c} and \mathbf{e} is equal to the trace of the SM in (4.1).

The general algorithm (GA) originally introduced in [285] for the DS enumeration of the general class of GNU trellis codes has been modified in Paper IX to enumerate all single error events in punctured CCs with respect to their Hamming distance vector and the eigenvalue-equivalent SM. The algorithm consists of five phases: i.e., initialization, the main step, the comparisons, the check for merging paths, and the end of the algorithm. Being proportional to the square of the number of encoder trellis states Q , the computational complexity of the GA has not been a considerable issue as it was applied for low constraint-length CCs. Unlike the convolutional codes where compounded error events can be expurgated from the UB without loss of accuracy [486], the proper representation of the STTuCM, as for any block code, requires enumeration of the concatenated error events. The single error events that diverge from an arbitrary state q , $q = 1, \dots, Q$ at time instant $l = 1, 2$, were after enumeration with the GA concatenated to form a set of all compounded error events diverging in an arbitrary time instant l , $l = 1, \dots, L$ and consisting of an arbitrary number of single error events. The DS interpretation of STTuCM over quasi-static fading channels was applied for the FER UB analysis in Paper IX and for design of the new CCs for robust STTuCM in Paper XI.

On fast fading channels, de-multiplexing the error event $\{\mathbf{c} \rightarrow \mathbf{e}\}$ onto $\{\mathbf{c}^1 \rightarrow \mathbf{e}^1\}$ and $\{\mathbf{c}^2 \rightarrow \mathbf{e}^2\}$ directly decomposes the EHD and EPD as

$$\Delta_{\text{H}}(\mathbf{c}, \mathbf{e}) = \Delta_{\text{H}}(\mathbf{c}^1, \mathbf{e}^1) + \Delta_{\text{H}}(\mathbf{c}^2, \mathbf{e}^2) \quad (4.2)$$

$$\Delta_{\text{P}}(\mathbf{c}, \mathbf{e}) = (\Delta_{\text{P}}(\mathbf{c}^1, \mathbf{e}^1))^{\frac{\Delta_{\text{H}}(\mathbf{c}^1, \mathbf{e}^1)}{\Delta_{\text{H}}(\mathbf{c}, \mathbf{e})}} (\Delta_{\text{P}}(\mathbf{c}^2, \mathbf{e}^2))^{\frac{\Delta_{\text{H}}(\mathbf{c}^2, \mathbf{e}^2)}{\Delta_{\text{H}}(\mathbf{c}, \mathbf{e})}}. \quad (4.3)$$

The above properties of the SM from (2.8) directly follow from (2.9). For the i th CC, $\Delta_{\text{H}}(\mathbf{c}^i, \mathbf{e}^i)$ denotes the number of non-zero eigenvalues λ_l in (2.9) for $l = 2j + i$, $j = 0, \dots, L/2 - 2$ while $\Delta_{\text{P}}(\mathbf{c}^i, \mathbf{e}^i)$ is their geometric mean. The multiplicity of the error events $\{\mathbf{c} \rightarrow \mathbf{e}\}$ with the EHD and the EPD given by (4.2) and (4.3) has been obtained as a product of multiplicities of the two de-multiplexed error events $\{\mathbf{c}^1 \rightarrow \mathbf{e}^1\}$ and $\{\mathbf{c}^2 \rightarrow \mathbf{e}^2\}$ averaged by the probability of their joint occurrence. As in the slow fading case, only the error events with the same value of the Hamming distance vector were statistically combined. The DS with respect to the Hamming distance vector, the EHD, and the EPD in each of the CCs was enumerated in Paper X applying the modified GA. Following the concatenation of single error events into compounded error events, the distance spectra from the two CCs were statistically combined to arrive at the DS of STTuCM with respect to the Hamming distance vector, the EHD, and the EPD. The DS interpretation of STTuCM over fast fading channels was applied for the FER UB analysis in Paper X and for further STTuCM optimization in Paper XII. Notice that the DS interpretation in general can be efficiently utilized for the code-matched information interleaving design, as was done for the single antenna binary TuCs in [125].

4.3.2 Union bound over slow and fast fading channels

Let us truncate the UB in (2.10) by replacing set \mathcal{D} with its subset \mathcal{P} . The subset \mathcal{P} is denoted as *significant* part of the code's DS if adding any disjoint element from \mathcal{D} to \mathcal{P} has a negligible effect to truncated sum in (2.10). The truncated UB on the FER of the STTuCM over quasi-static and fast fading channels was assessed in Papers IX and X, respectively. The main bottleneck of the presented DS interpretation is not its computational complexity but the memory requirements. On slow fading channels, a $4 + N^2$ dimensional variable has to be enumerated in each CC during the DS evaluation, i.e., 4 elements of the Hamming distance vector and N^2 elements of the SM. On fast fading channels a 6 dimensional variable is enumerated, i.e., 4 elements of the Hamming distance vector and 2 elements for the EHD and the EPD. With the further error event concatenation inside the CCs and their statistical combining over all possible realizations of the uniform information interleaving, the DS of STTuCM becomes extremely rich. To reduce the memory requirements of the algorithm, the information error events $\{\mathbf{x} \rightarrow \hat{\mathbf{x}}\}$ can be sufficiently characterized only by their Hamming distance once the statistical combining is completed.

The choice of parameters that for a given code uniquely determine its significant part of the DS is a complex multi-dimensional problem. To evaluate the UB of the STTuCM over quasi-static fading channels in Paper IX, given the memory constrains of the DS interpretation algorithm, all punctured single error events with a Hamming distance up to $h_{\max} = 5$, a sequence length up to $l_{\max} = 7$, and an EPD up to $p_{\max} = 12$ were first enumerated in each of the CCs. Compounded error events consisting of up to $k_{\max} = 3$ single error events were then formed. On fast fading channels, the significant part of the DS was easily identified in Paper X by $h_{\max} = 6$, $l_{\max} = 6$, $p_{\max} = 16$, and $k_{\max} = 3$. Despite the large increase in the number of DS entries, further increase in any of the parameters h_{\max} , l_{\max} , p_{\max} , and k_{\max} for fast fading channels has been empirically found to insignificantly contribute to the sum in (2.10).

Papers IX and XII revealed that the two-dimensional DS of STTuCM over quasi-static fading channels has non-zero entries $H(\Delta_H, \Delta_P)$ for $\Delta_H < N$, i.e., the punctured parallel concatenation with uniform information interleaving in general does not preserve the full rank of its CCs. For the fully recursive configuration, a quite large “code energy” concentrated in the rank deficient part of the DS severely deteriorated the performance. On the other hand, the non-fully recursive configuration experienced a negligible performance deviation away from the second order diversity slope in the range of low-to-medium SNRs typically exhibited in practice. Such findings implicated that the relatively restrictive requirement for the full rank of all possible ST codeword difference matrices could be released considering only the significant part of the DS. With no impact on the attainable performance in practice, this could significantly increase the set of candidate codes for coding gain optimization. Papers IX and XII further showed that the non-fully recursive STTuCM significantly outperforms the 64-state Tarokh-STTrC despite its considerably lower minimum EPD. This illustrated the importance of the DS to the performance and optimization of STCs. It was also an early indication that the determinant criterion, commonly applied for stand-alone STTrCs may not necessarily be adequate

for CC optimization in the STTuCM.

The UB analysis in Paper X revealed that the superior performance of the fully recursive over the non-fully recursive STTuCM, seen by simulations over block fading channels with $B > 1$, comes from its better DS characteristics over fast fading channels. The configuration with both Rec-STTrCs also exhibited a stronger water-falling effect, i.e., the higher slope in the transition region towards the “error-floor”. The error-floor here refers to the asymptotical high SNR behavior with the slope of the FER curve characterized by the diversity order attained by the MLD. The UB in the water-falling region is typically loose but is commonly expected to well represent the asymptotically high SNR performance [120]. The low-complexity sub-optimal iterative decoding employed for simulations was concluded to converge successfully to the performance of the optimal MLD already after ten iterations. The non-fully recursive STTuCM configuration experienced no performance degradation in the low SNR region, i.e., the water-fall and error-floor regions were indistinguishable. The reasons for such an interesting behavior were revealed in Paper XI where the iterative decoding convergence of STTuCM was analyzed. The introduced tools can be readily applied for the UB analysis of the general class of GNU single antenna TuCMs from [196] over AWGN and fading channels.

To tighten a quite loose upper bound on the FER performance of stand-alone STTrCs over quasi-static fading channels, authors in [287] prelimited the conditional PEP to one prior to the applied numerical integration over the fading. This method was originally introduced in [487] for stand-alone convolutional codes arguing that the lack of temporal diversity typically prevents dominant error events in the DS to arise, causing the “explosion” of the UB over slow fading channels. The same technique was recently applied in [432] for upper bounds on turbo coded multi-antenna systems. As no additional bounding of the conditional PEP was performed in Papers IX and XII, derived union upper bounds of STTuCM over quasi-static fading channels appeared to be rather optimistic. Nevertheless, they gave good insight into a non-trivial two-dimensional DS of the STTuCM and turned out to be a rather useful tool for CC design and optimization in Paper XI. On the other hand, the union upper bound of STTuCM over fast fading channels in Paper X appeared to be rather tight. The similar tightness of the UB for stand-alone STTrCs on fast fading channels was observed in [287] and Paper XII.

4.3.3 Iterative decoding convergence analysis

Paper XI studied the dynamics of the iterative decoding algorithm for different configurations of the STTuCM with 8-state QPSK CCs. A summary and comparison of different measures proposed in the literature for tracking the exchange of extrinsic information between the constituent decoders in an iterative decoding scheme can be found in [488, 489]. The concatenation of the bit-to-symbol reliability transform, the symbol-by-symbol MAP decoder, and the symbol-to-bit reliability transform from Fig. 4.2, denoted here as a component decoder was modelled as a non-linear system with a certain transfer function. Similar to [490, 488], Paper XI adopted

the i.i.d. symmetric Gaussian approximation with mean μ_i^i and μ_i^o for the extrinsic information at the input and the output of the i th, $i = 1, 2$, non-linear system. The SNR at the input of the i th decoder, i.e., SNR_{di}^i was varied and the corresponding output SNR, i.e., SNR_{di}^o measured to empirically determine the non-linear transfer function G_i . Large information block sizes of 2000 bits were considered discarding the 200 bits at the edges of the blocks when measuring the mean value of the output extrinsic information. The evolution of the extrinsic information can be traced by plotting functions $\text{SNR}_{\text{d1}}^o = G_1(\text{SNR}_{\text{d1}}^i)$ and $\text{SNR}_{\text{d2}}^i = G_2^{-1}(\text{SNR}_{\text{d2}}^o)$ on the same graph.

The convergence threshold is defined as the channel SNR value at which two transfer functions just touch. It is a common understanding that if the two curves intersect each other, i.e., the “tunnel” of iterative decoding is closed, the decoder does not converge [490, 488]. Likewise, when tunnel is open, the SNR_{di}^o of the extrinsic information increases over iterations without bound. In practise, this means that the probability of error, inversely proportional to such SNR_{di}^o [490] converges towards the error-floor defined by the DS and the UB of the code. Therefore, the probability of error does not fall without bound even with a large number of iterations. Although it is difficult to establish a general relation between the extrinsic information SNR_{di}^o and the probability of error, it is easy to imagine that the error-floor can be reached even with a finite, large enough value of SNR_{di}^o .

The convergence threshold for the fully-recursive STTuCM over AWGN channels was determined in Paper XI to be $\text{SNR}=5.4$ dB. The tunnel of iterative decoding for the non-fully recursive STTuCM was found to never be open. The first CC being non-recursive has a zero asymptotic slope of its extrinsic information transfer function, which conflicts with the asymptotic slope one of the recursive second CC. However, due to the almost complementary outlook of its transfer functions at low SNR_{di}^i , the non-fully recursive STTuCM enables reasonably good evolution of its extrinsic information after 10 decoding iterations. At the channel $\text{SNR}=5.4$ dB, the non-fully recursive STTuCM has a remarkably larger value of SNR_{di}^o than the recursive one whose tunnel is pinched at a very low value of SNR_{di}^o . As seen from Paper XI, even the lower values of the channel SNR enable a reasonable evolution of SNR_{di}^o for the non-recursive configuration. The transfer function curves in Paper XI were obtained with the assumption of an AWGN channel. The quasi-static fading channel causes the effective channel SNR to vary from one frame to another. Therefore, good convergence properties are essential for the performance of turbo-like codes over quasi-static fading channels [490]. Adding to it a less deteriorating effect of the rank deficient part of the DS, it is easy to understand the superior performance of the non-fully recursive STTuCM over the fully recursive one experienced by simulations over quasi-static fading channels. On fast fading channels, where good DS characteristics play a more important role, the fully-recursive STTuCM outperformed the non-fully recursive one in spite of its inferior convergence properties. The iterative decoding convergence properties of the CCs from Papers I, II, and III were also studied in [413] where the system model assumed the symbol-wise STTuCM.

4.4 Constituent code design and optimization

The following subsections summarize the main contributions of Papers XI and XII that tackled the interesting problem of CC design for STTuCM based on the DS and iterative decoding convergence analysis.

4.4.1 Design criteria

The state of the art in ST coding design has almost exclusively concentrated around the design criteria targeting the error coefficients, i.e., maximizing the minimum EHD and EPD. Such optimization does not take into account either the effect of pair-wise error events with the EHD and the EPD above the minimum nor the contribution of multiplicities to the UB in (2.10). As a result different codes with the same minimum EHD and EPD sometimes resulted in different performance when compared through simulations. Section 4.3.2 further revealed that the non-fully recursive STTuCM significantly outperforms the 16-state Tarokh-STTrC despite its considerably lower minimum EPD.

Papers XI and XII introduced the modified design criteria for STCs over quasi-static and fast fading channels that capture the joint effects of error exponents and multiplicities in the code's DS:

- *Significant full rank.* To maximize the diversity gain over quasi-static fading channels, the STC must satisfy the full rank criterion in its significant part of the DS, i.e., $H(\Delta_H, \Delta_P) = 0$ for $\forall \langle \Delta_H, \Delta_P \rangle \in \mathcal{P}|_{\Delta_H < N}$.
- *Minimum spectral product.* To maximize the coding gain, among all STCs that satisfy the significant full rank criterion, choose the one that minimizes

$$\Delta_{DS} = \sum_{\langle \Delta_H, \Delta_P \rangle \in \mathcal{P}|_{\Delta_H = N}} H(\Delta_H, \Delta_P) \Delta_P^{-\Delta_H M}. \quad (4.4)$$

with Δ_H and Δ_P defined over the SM in (2.3).

The importance of the DS, though in the context of stand-alone STTrCs and methods for its optimization, were also studied in [491] in parallel. The recent attempt to apply similar criteria from (4.4) to fast fading channels was done in [492]. However, on fast fading channels, it is not possible to accurately remove the SNR term from the DS optimization. The pair-wise error events with the same EPD may in general have different lengths and therefore experience different levels of diversity. Hence, given the SNR point, the STTuCM optimization over fast fading channels in Paper XII assumed the minimization of the truncated UB in (2.10).

4.4.2 Subset of constituent codes for optimization

In contrast to Papers I, II, III, and VI where CCs were represented with trellis diagrams, Papers XI and XII adopted the transform domain model with binary generator polynomials. To each of K parallel input bits from $\mathbf{x}(l) = [x_1(l), x_2(l), \dots, x_K(l)]$, a binary recursive feedback shift register with a memory order ν_k , $k = 1, \dots, K$, was associated. The sum $\nu = \nu_1 + \nu_2 + \dots + \nu_K$ denoted the total memory order of the CC and each ν_k satisfied $\lfloor \nu/K \rfloor \leq \nu_k \leq \lceil \nu/K \rceil$. Dropping the subscript for constituent code, each $c_n(l)$ was assumed to be the result of mapping Z coded bits $\mathbf{y}_n(l) = [y_n^1(l), y_n^2(l), \dots, y_n^z(l)]$ to a given 2^Z level amplitude and/or phase modulation. Figure 4.3 depicts the k shift register and its relation with the u th register, $k, u = 1, \dots, K$. Introducing an indeterminate D to denote a delay operator, the input/output relations can be represented using a binary polynomial arithmetic relation

$$y_n^z(D) = \sum_{k=1}^K (f_{nzk}^x x_k(D) + f_{nzk}(D) a_k(D)) \quad (4.5)$$

with $z = 1, \dots, Z$ and $a_k(D)$ denotes a signal entering the k th shift register

$$a_k(D) = \sum_{u=1}^K (b_{ku}^x x_u(D) + b_{ku}(D) D a_u(D)). \quad (4.6)$$

f_{nzk}^x and b_{ku}^x are binary constants, $f_{nzk}(D)$ is a degree ν_k binary feed-forward polynomial from shift register k to the output bit z at the transmit antenna n , $b_{ku}(D)$ is a degree $\nu_u - 1$ binary feed-backward polynomial from shift register u to the input of shift register k . Papers XI and XII considered the limited case of $N = K = Z = 2$, $\nu = 3$ ($\nu_1 = 1, \nu_2 = 2$) and the natural QPSK mapping, i.e., $c_n(l) = \exp\{\sqrt{-1} \frac{\pi}{2} (y_1^n(l) + 2y_2^n(l))\}$. The above special case covers a quite large set of 2^{38} 8-state CCs with a bandwidth efficiency of 2 bps/Hz. Papers XI and XII further constrained the set of candidate codes to:

- A subset of systematic CCs since they were shown in [488] for classical single antenna TuCs to result in better convergence of sub-optimal iterative decoding. Therefore the following parameters were chosen: $f_{112}^x = f_{121}^x = 1$, $f_{112}(D) = f_{121}(D) = 0$, $f_{122}^x = f_{111}^x = 0$, $f_{122}(D) = f_{111}(D) = 0$, $f_{212}^x = f_{222}^x = f_{211}^x = f_{221}^x = 0$.
- Fully connected trellises without parallel transitions, i.e., $b_{11}^x = b_{22}^x = 1$ and $b_{12}^x = b_{21}^x = 0$, respectively.

Solving (4.5) and (4.6) with the above assumptions, the input-output relations in the CC can be further simplified as

$$y_1^z(D) = x_{(3-z)}(D) \quad (4.7)$$

$$y_2^z(D) = \sum_{k=1}^2 \frac{f_{zk}^e(D)}{b^e(D)} x_k(D) \quad (4.8)$$

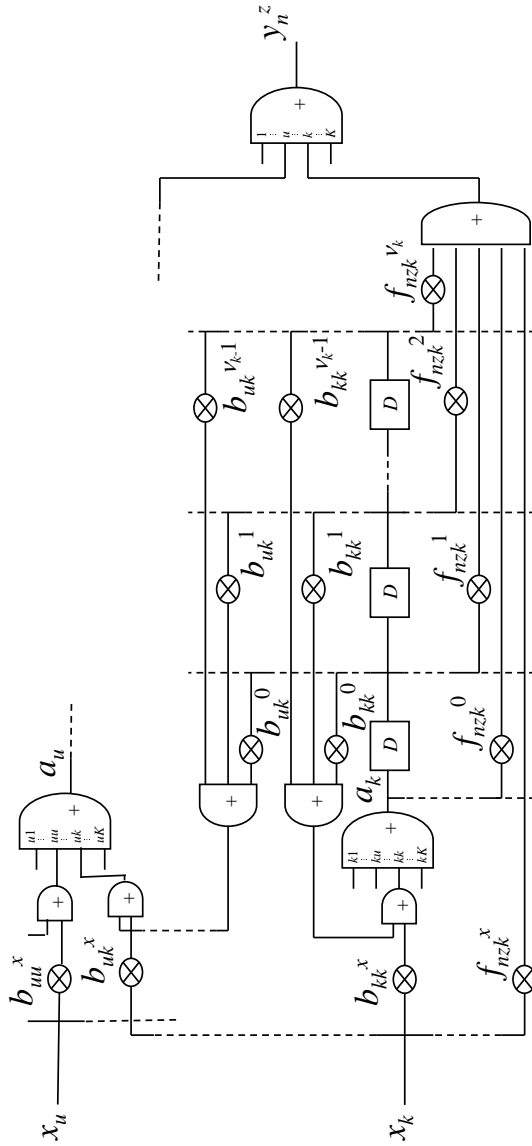

Fig. 4.3. The k th shift register in the constituent code.

with $z = 1, 2$ and the equivalent feed-forward and feed-backward polynomials given as

$$f_{zk}^e(D) = f_{2zk}(D) (1 + Db_{(3-k)(3-k)}(D)) + Df_{2z(3-k)}(D) b_{(3-k)k}(D) \quad (4.9)$$

$$b^e(D) = 1 + (b_{11}(D) + b_{22}(D))D + (b_{11}(D)b_{22}(D) + b_{12}(D)b_{21}(D))D^2. \quad (4.10)$$

Due to recursive feedback, the finite size codeword difference matrices are caused by the information error events $\{\mathbf{x} \rightarrow \hat{\mathbf{x}}\}$ with a minimum Hamming distance of 2. Four types of such information error events were identified in Paper XI. It was further shown that choosing the primitive polynomial for $b^e(D)$ contributes well to the maximization of the minimum length of such Hamming distance 2 information error-events. Following the intuition from [112], this is expected to result in codeword difference matrices increasing the EHD and EPD. A primitive $b^e(D)$ is also foreseen to result in better convergence of iterative decoding [488]. Notice that a degree ν binary polynomial $b^e(D)$ is a function of feed-backward polynomials only. Solving $b^e(D) = 1 + D + D^3$ resulted in 4 sets of feed-backward polynomials, with the best 2 sets chosen for further consideration.

4.4.3 Distance spectrum optimization

The separate optimization of backward polynomials in the previous subsection reduced the number of candidate CCs to 1024 for each of the two chosen sets of feed-backward polynomials. The DS optimization over quasi-static fading channels in Paper XI performed the search over the feed-forward polynomials $f_{2zk}(D)$, $z, k = 1, 2$, that result in the STTuCM that best satisfied the significant full rank and minimum spectral product design criteria. Only the punctured full-rate STTuCM was considered. The transform domain model for CCs was plugged into the system model for STTuCM from Section 4.1. To simplify the code search, both CCs in the parallel concatenation were chosen to be the same. To increase the number of STTuCMs that satisfy the significant full rank criterion, the outputs of the second CC were altered before transmission from N transmit antennas. Referring to Subsection 4.1.1, the resulting STTuCM coded frame $\mathbf{c} = [\mathbf{c}(1), \mathbf{c}(2), \dots, \mathbf{c}(L)]$ was given by $\mathbf{c}(l) = [c_1^1(l), c_2^1(l), \dots, c_N^1(l)]$ for l odd and $\mathbf{c}(l) = [c_N^2(l), c_{N-1}^2(l), \dots, c_1^2(l)]$ for l even.

The significant part of the DS, i.e., the set \mathcal{P} , has been identified by $h_{\max} = 3$, $l_{\max} = 8$, $p_{\max} = 12$ and $k_{\max} = 3$. To decrease the cardinality of \mathcal{P} and simplify the code search, h_{\max} was reduced compared to the UB analysis from Subsection 4.3.2 which is partly compensated for by the slightly increased l_{\max} . Table 4.1 summarizes the results of the CC search where $\mathbf{B} = [b_{11}(D); b_{12}(D); b_{22}(D); b_{21}(D)]$ with $b_{ku}(D) = b_{ku}^0 + b_{ku}^1 D + \dots + b_{ku}^{\nu_u-1} D^{\nu_u-1}$ and $\mathbf{F} = [f_{212}(D); f_{211}(D); f_{222}(D); f_{221}(D)]$ with $f_{2zk}(D) = f_{2zk}^0 + f_{2zk}^1 D + \dots + f_{2zk}^{\nu_k} D^{\nu_k}$. Out of 1024 candidate CCs for each \mathbf{B}_1 and \mathbf{B}_2 , 30 codes resulted in an STTuCM that satisfied the significant full rank criterion. A further search over the minimum spectral product produced two codes for each of \mathbf{B}_1 and \mathbf{B}_2 with all codes resulting in an STTuCM with the same value of Δ_{DS} in (4.4).

Table 4.1. The best $\nu = 3$ QPSK recursive systematic constituent codes for 2 bps/Hz STTuCM over quasi-static fading channels.

CC	\mathbf{B}	\mathbf{F}
Q_A	$\begin{bmatrix} 1 & 0 \\ 1 & 0 \\ 0 & 1 \\ 1 & 0 \end{bmatrix}$	$\begin{bmatrix} 1 & 0 & 1 \\ 1 & 1 & 0 \\ 0 & 0 & 1 \\ 1 & 0 & 0 \end{bmatrix}$
Q_B	$\begin{bmatrix} 1 & 0 \\ 1 & 0 \\ 0 & 1 \\ 1 & 0 \end{bmatrix}$	$\begin{bmatrix} 1 & 0 & 1 \\ 1 & 1 & 0 \\ 1 & 0 & 0 \\ 0 & 1 & 0 \end{bmatrix}$
Q_C	$\begin{bmatrix} 1 & 0 \\ 0 & 1 \\ 0 & 0 \\ 1 & 0 \end{bmatrix}$	$\begin{bmatrix} 1 & 1 & 0 \\ 1 & 1 & 0 \\ 0 & 1 & 1 \\ 1 & 0 & 0 \end{bmatrix}$
Q_D	$\begin{bmatrix} 1 & 0 \\ 0 & 1 \\ 0 & 0 \\ 1 & 0 \end{bmatrix}$	$\begin{bmatrix} 1 & 1 & 0 \\ 1 & 1 & 0 \\ 1 & 0 & 1 \\ 0 & 1 & 0 \end{bmatrix}$

To justify the assumptions made on the importance of the systematic nature of CCs and its primitive equivalent feed-backward polynomial, Paper XI demonstrated that the new CCs result in a 0.5 dB lower convergence threshold for STTuCM compared to previously considered recursive Tarokh-STTrCs.

Simulations over quasi-static and fast frequency flat fading channels demonstrated the robustness of STTuCM with CCs from Table 4.1. Newly designed STTuCM outperformed both the fully recursive and non-fully recursive STTuCM with constituent Tarokh-STTrCs. A full spatial diversity was achieved with no constraints on the implemented pseudo-random information interleaving. This left plenty of freedom for further improvement with the special information interleaving design. New CCs for fast fading channels were designed similarly in Paper XII. Such CCs offered an additional performance gain for STTuCM over fast fading channels. However, they resulted in STTuCM that does not satisfy the significant full rank criterion if defined with respect to the same set \mathcal{P} used for quasi-static fading optimization. Interestingly enough, noticeable performance degradation over quasi-static fading channels was foreseen by the UB only for large SNR values, high above those typically exhibited in practice.

4.4.4 Comparison between bit and symbol interleaving

The bit versus symbol information interleaving for the single antenna TuCM from [197] was recently studied in [227, 226, 229]. Due to potential information loss induced during symbol-to-bit and bit-to-symbol transformations in the decoder, the convergence threshold for iterative decoding of symbol-wise interleaved TuCM was concluded in [227] to be around 0.5 dB lower than in the case of bit-wise interleaved TuCM. Such behavior was confirmed by BER Monte-Carlo simulations over an AWGN channel. On the other hand, bit-wise interleaving is expected to result in better DS properties due to a more exaggerated spectral thinning effect. Independently mapping K input bits from the given input symbol allows spreading the components of one error event to approximately K times more error events, typically accumulating more distance. This is especially important for robust performance over fading channels where long, multiple-concatenated single error events experience more diversity. A comprehensive treatment of the pros and cons of the single-antenna and multi-antenna TuCMs operating on the bit or symbol level over fading channels is an open interesting topic left for future work. An early unpublished treatment of the topic, performed by the author prior to Paper I, concluded that bit-wise interleaving indeed offers better performance for STTuCM over fading channels. Some performance examples that confirm such conclusions were presented in Papers IV and V where the CCs proposed by Cui and Haimovich in [404] were compared under the bit-wise and the symbol-wise interleaved STTuCM. The bit and symbol level STTuCM with the newly designed CCs were further studied in Paper XII, which included a performance comparison with the symbol level STTuCM from [405, 413].

The new CCs from Table 4.1 were designed to satisfy the significant full rank criterion for an arbitrary realization of pseudo-random bit-wise information interleaving. Therefore, the full spatial diversity over quasi-static fading channels is guaranteed *a priori* also in the special case when all the K information interleavers have the same pattern, i.e., for symbol-wise information interleaving. The comparison between the bit-wise and symbol-wise interleaved STTuCM with the newly designed constituent code Q_C from Table 4.1 over quasi-static and fast fading channels is depicted in Figs. 4.4 and 4.5, respectively. The two schemes are denoted as “STTuCM b/w 2x8st CC- Q_C ” and “STTuCM s/w 2x8st CC- Q_C ”, respectively. In the quasi-static fading case no performance difference between the two interleaving realizations was exhibited. Both schemes perform within 1.5 dB away from channel outage capacity. However, on the fast fading channel, a significant improvement of the bit level STTuCM was seen, i.e., more than 3 dB gain at FER 10^{-3} is achieved compared to the STTuCM operating on the symbol level. For comparison Figs. 4.4 and 4.5 also include the performance of the symbol level STTuCM proposed by Firmanto, Chen, Vucetic, and Yuan (FCVY) in [405, 413]. The scheme is denoted as “STTuCM s/w 2x8st CC-FCVY” and also employs the 8-state CCs. With no particular optimization other than that regularly applied for CCs as stand-alone STTrCs, the STTuCM from [413] failed to achieve full spatial diversity over quasi-static fading channels. On fast fading channels, a performance loss was also induced compared to both the bite-wise and symbol-wise realizations of the STTuCM advo-

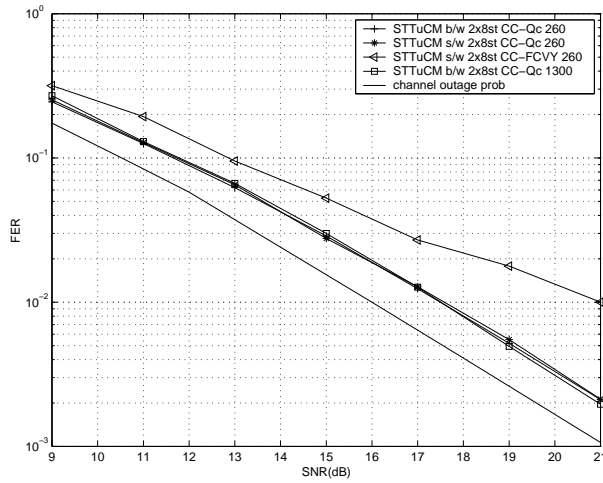

Fig. 4.4. The comparison between STTuCMs operating on the bit level and symbol level over quasi-static fading channels, 8-state CCs, 10 decoding iterations, input information frame of $LK = 260, 1300$ bits, $N = 2$, $M = 1$.

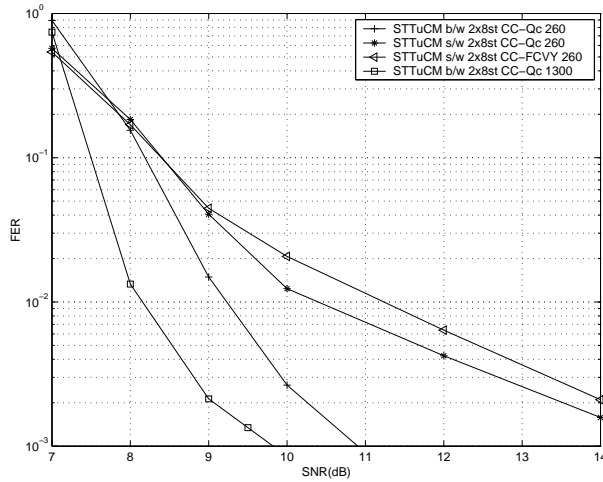

Fig. 4.5. The comparison between STTuCMs operating on the bit level and symbol level over fast fading channels, 8-state CCs, 10 decoding iterations, input information frame of $LK = 260, 1300$ bits, $N = 2$, $M = 1$.

cated in this thesis. The main reason for that, as seen throughout Sections 4.3 and 4.4, comes from the fact that design issues of the CCs in STTuCM are considerably different from those related to stand-alone STTrCs. Also, in contrast to stand alone STTrCs where a significant performance degradation was induced, e.g., see Paper I, the bit-wise STTuCM with increased frame size achieved a considerable gain directly proportional to the number of independent fading blocks per frame.

5 Conclusions

Novel ST signalling methods and transceiver algorithms for reliable and bandwidth efficient transmission with performance close to MIMO link capacity limits were designed and analyzed in this thesis. The work concentrated on the subgroup of coherent ST coding schemes optimized under the assumption of no available CSI at the transmitter and the optimal MLD with perfect CSI at the receiver. The following sections briefly discuss the main results and contributions of the thesis and point out directions for further development.

5.1 Summary and discussion

The introductory chapter of the thesis gave the reasoning for the recent renaissance in spatial and temporal signal processing. Increased link capacity was identified as one of the key requirements for emerging wireless data systems. The latest findings in information theory and the results of different field measurement campaigns on the channel capacity of multiple antenna systems were reviewed.

The basic notations and the background knowledge for understanding the main contributions of the thesis were introduced in Chapter 2. The relevant developments in both turbo and space-time coding that preceded but also evolved in parallel to the development of this thesis were reviewed.

The scope of the thesis was introduced in Chapter 3. Several interesting open problems that motivated the work of this thesis were identified. The main contributions of the thesis were briefly summarized. The relation of the thesis to the parallel work on space-time turbo coding was carefully examined. Different proposals for multi-antenna turbo coded modulations in the literature were classified based on the single antenna turbo coded modulations they evolved from.

Chapter 4 summarized the appended original publications. The chosen sectioning reflected the various important aspects of STTuCM, which was originally introduced and studied in this thesis. The STTuCM cleverly integrated the code concatenation in a random-like coding approach. The large equivalent constraint length and

randomness were jointly provided by an information interleaver, a building block that due to iterative decoding did not add considerably to decoding complexity. The systematic procedure for building an equivalent recursive STTrC based on the trellis diagram of an arbitrary non-recursive STTrC was introduced. While both parallel and serial concatenated STTuCMs have been introduced in this thesis, the main focus was placed on parallel code concatenation. The parallel concatenation of punctured constituent recursive STTrCs designed upon feedforward Tarokh-STTrCs resulted in increased coding and diversity gains compared to the state of the art, low constraint-length STTrCs. Severe puncturing with no particular optimization of the CCs destroyed the rank properties of STTuCM. However, it was demonstrated that by replacing one of the CCs with the original non-recursive Tarokh-STTrC, the resulting STTuCM managed to preserve full spatial diversity over quasi-static fading channels in the region of low to medium SNRs typically exhibited in practice. With more than one independent fading block per transmission frame, the configuration with both recursive STTrCs was advocated as preferable due to significantly better performance.

Due to the decoding complexity of its CCs, generally increasing exponentially with the transmission rate and the number of transmit antennas, the study of STTuCM was restricted to two transmit antennas. To achieve the higher bandwidth efficiencies employing an arbitrary number of transmit antennas, the combined generalized LST coding and STTuCM were introduced. Although the signalling method considered is more general, a frequency selective WCDMA downlink channel was chosen for the application scenario. To further remove the complexity burden from future WCDMA mobile terminals, orthogonalized spatial multiplexing as a combination of coded spatial multiplexing and WCDMA delay diversity was proposed. While some more advanced multiuser detection based receiver can be applied, the RAKE receiver followed by a channel decoder was assumed in this thesis to keep the receiver simple. The application of STTuCM to MIMO-OFDM achieved high data rates over broadband radio channels exploiting the considerable frequency selectivity offered in typical low mobility indoor environments. A simple way of combining space-frequency coding with OFDM delay diversity for cost effective exploitation of more than two transmit antennas was also proposed in this thesis.

The simulation results motivated further theoretical analysis. DS interpretation, the UB performance of over slow and fast fading channels, and the iterative decoding convergence analysis were studied in this thesis. The analysis revealed the reasons for the diverse behavior of fully and non-fully recursive STTuCMs. The DS analysis gave good insight into the importance of multiplicities for ST coding design. To enable tractable analysis, the information interleaver between CCs in parallel concatenation was assumed to be random with uniform distribution resulting in the upper bound on the performance of MLD averaged over all different information interleavers. The modified design criteria for STCs that capture the joint effects of error coefficients and multiplicities in a two-dimensional code's DS were introduced. Applied to STTuCM, such DS optimization produced a new set of CCs for two transmit antenna and QPSK modulation. The resulting STTuCM demonstrated a robust and improved performance over both slow and fast fading channels. The design issues of the CCs in STTuCM were shown to be consider-

ably different from those related to stand-alone STTrCs. Also, in contrast to stand alone STTrCs where a significant performance degradation was seen, the bit-wise STTuCM with increased frame size achieved the additional gains directly proportional to the number of independent fading blocks per transmission.

A recursive systematic form with a primitive equivalent feedback polynomial was assumed for CCs to assure the good convergence of iterative decoding. To justify such assumptions, iterative decoding convergence analysis based on the Gaussian approximation of extrinsic information was studied. With no constraints on the implemented information interleaving, the STTuCM constructed from newly introduced recursive systematic STTrCs achieved full spatial diversity over quasi-static fading channels. This is the condition identified as the most restrictive one for robust performance over a variety of Doppler spreads. This left much scope for further improvement by optimizing the information interleaving. Finally, the pros and cons of bit and symbol level processing with respect to DS and iterative decoding convergence were discussed. In the quasi-static fading case both schemes approached the two transmit and single receive antenna MIMO outage capacity within 1.5 dB, i.e., no performance difference between the two interleaving realizations was exhibited. However, on a fast fading channel, the superior performance of the bit level STTuCM was evident. The similar STTuCMs studied independently and in parallel to this thesis were shown to be inferior compared to the new fully optimized STTuCM.

The main benefit of the newly proposed STTuCM comes from its improved performance for a variety of application scenarios. The tradeoff between the performance gain and the increased decoding complexity, as typically examined for single antenna turbo and convolutional codes, is difficult to evaluate here. To date, there are no proposals in the literature for optimized large constraint-length STTrCs. Some non-optimized brute force designed 256-state STTrCs were shown in this thesis to offer considerably inferior performance compared to the new STTuCM.

From a practical viewpoint, the main disadvantage of the proposed STTuCM lays in its limited flexibility. Common to all TCM based methods, an adaptive realization of the scheme requires a changing the trellis definition for each modulation mode of transmission. Also, puncturing, applied here on the symbol level, reduces the variety of possible transmission rates as compared to schemes with separated coding and modulation. Technical designs in general that are more compatible with off-the-shelf products typically enjoy more wide spread acceptance on the market. Therefore, the question can also be posed as to whether the STTuCM, in spite of its improved performance, is sufficiently pragmatic to secure its application in practical system. Addressing both commercial as well as technical issues, the final answer is thus out of the scope of this thesis.

5.2 Future research directions

Several issues related to the subjects investigated lend themselves to the further development. The introduced DS interpretation with respect to an arbitrarily defined

EHD and EPD is applicable to the general class of GNU CCs. The newly introduced, modified design criteria for DS optimization can be extended to any of the existing minimum pair-wise error probability based criteria for STC design. The adopted transform domain model with generator polynomials enables a straightforward optimization of CCs for an arbitrary number of transmit antennas and modulation levels. The interesting special case of CC optimization for single antenna TuCMs over AWGN or fading channels is left for the future work. The introduced DS interpretation with respect to the Hamming distance vector, the EHD and the EPD can be utilized to identify the error events with the largest contribution to the UB. Their average multiplicity, i.e., the probability of occurrence can be further reduced with special design of the information interleaving. Unlike other space-time turbo code proposals in the literature, this can lead to above average performance without sacrificing the robustness of the STTuCM, i.e., its rank properties.

The combined generalized LST coding and STTuCM can be further reinforced by applying hard and soft decision based interference cancellation. The application of such a low-complexity method for MIMO-OFDM systems with a large number of transmit and receive antennas is an interesting topic for future work. The application of orthogonalized spatial multiplexing for a WCDMA downlink with more advanced receivers should also be taken into consideration. The new application scenarios for STTuCM include MC-CDMA, with an early reference already pointed out in this thesis.

The performance of STTuCM was evaluated in this thesis utilizing log-MAP symbol-by-symbol component decoders and assuming ideal CSI and SNR estimation. The impact of CSI and SNR estimation errors on the performance of STTuCM requires further study. The comparison with sub-optimal but more robust max-log-MAP and symbol-by-symbol SOVA algorithms is an interesting open topic. The robustness against different Doppler spreads with more realistic channel models than the block fading channels utilized is also required. Apart from MIMO-OFDM application scenario, STTuCM was principally evaluated for the short frame sizes. The obtainable performance gains in practical systems should be carefully examined choosing more specific physical layer parameters, i.e., frame structures. The impact of spatial fading correlation was not addressed in this thesis. Further studies should determine whether the combination of recursive CCs and information interleaving, through spectral thinning, assures good robustness for a variety of angular spreads as it did for Doppler spreads. The analysis of all real-life nonidealities is impossible without hardware simulations. At the present time, there are industry partners interested in building testbeds and trial systems to determine the practical feasibility of the newly introduced multi-antenna signalling method. Such hardware development will also inevitably drive studies on all the relevant implementation related issues.

References

- [1] Shannon CE (1948) A mathematical theory of communications. The Bell System Technical Journal 27:379–423, 623–656.
- [2] Jakes WC (1974) Microwave Mobile Communications. John Wiley and Sons, New York.
- [3] Proakis JG (1989) Digital Communications. McGraw-Hill, New York, USA, 2nd edn.
- [4] Parsons JD (1992) The Mobile Radio Propagation Channel. Pentech Press, London.
- [5] Naguib A (1996) Adaptive antennas for CDMA wireless networks. Ph.D. Thesis, Stanford University, Stanford, USA.
- [6] Sklar B (1997) Rayleigh fading channels in mobile digital communication systems part i: Characterization. IEEE Commun Mag 35(7):90–100.
- [7] Sklar B (1997) Rayleigh fading channels in mobile digital communication systems part ii: Mitigation. IEEE Commun Mag 35(7):102–109.
- [8] Ertel RB, Cardieri P, Sowerby KW, Rappaport TS & Reed JH (1998) Overview of spatial channel models for antenna array communication systems. IEEE Pers Commun 5(1):10–22.
- [9] Wetzker G, Kaage U & Jondral F (1998) A simulation method for Doppler spectra. In: Proc. IEEE Int. Symp. Spread Spectrum Techniques and Applications, vol 2, 517–521.
- [10] Fulghum T & Molnar K (1998) The Jakes fading model incorporating angular spread for a disk of scatters. In: Proc. IEEE Veh. Technol. Conf., Ottawa, Canada, 489–493.
- [11] Rooyen PV, Lotter MP & Wyk DV (1999) Space-Time Processing for CDMA Communications. Kluwer Academic Publishers, Boston/Dordrecht/London, 1st edn.
- [12] Wang X & Poor H (1999) Space-time processing in multiple-access systems. In: Proc. IEEE Wireless Commun. and Networking Conf., vol 1, 129–133.
- [13] Fleury BH (2000) First- and second-order characterization of direction dispersion and space selectivity in the radio channel. IEEE Trans Inform Theory 46(6):2027–2044.

- [14] Stege M, Jelitto J, Bronzel M & Fettweis G (2000) A multiple input-multiple output channel model for simulation of Tx- and Rx- diversity wireless systems. In: Proc. IEEE Veh. Technol. Conf., Tokyo, Japan, 833–839.
- [15] Pedersen KI, Andersen JB, Kermaol JP & Mogensen P (2000) A stochastic multiple-input multiple-output radio channel model for evaluation of space-time coding algorithms. In: Proc. IEEE Veh. Technol. Conf., Tokyo, Japan, 893–897.
- [16] Hammerschmidt JS & Hutter AA (2000) Spatio-temporal channel models for the mobile station: Concept, parameters, and canonical implementation. In: Proc. IEEE Veh. Technol. Conf., vol 3, 1641–1645.
- [17] Kligenbrunn T & Mogensen P (2000) Modelling radio link performance in UMTS W-CDMA network simulations. In: Proc. IEEE Veh. Technol. Conf., vol 2, 1011–1015.
- [18] Chen TA, Fitz MP, Kuo WY, Zoltowski MD & Grim JH (2000) A space-time model for frequency non-selective rayleigh fading channels with applications to space-time modems. *IEEE J Select Areas Commun* 18(7):1175–1190.
- [19] Svantesson T (2000) A study of polarization diversity using an electromagnetic spatio-temporal channel model. In: Proc. IEEE Veh. Technol. Conf., Tokyo, Japan.
- [20] Ottersten T (1996) Array processing for wireless communications. In: Proc. Workshop Sign. Process. Statist. Array Process., 466–473.
- [21] Paulraj AJ & Papadias CB (1997) Space-time processing for wireless communications. *IEEE Signal Processing Mag* 14(6):49–83.
- [22] Godara LC (1997) Applications of antenna arrays to mobile communications, part I: Performance improvement, feasibility and system considerations. *Proc IEEE* 85(7):1031–1060.
- [23] Godara LC (1997) Applications of antenna arrays to mobile communications, part II: Beam-forming and direction-of-arrival considerations. *Proc IEEE* 85(8):1195–1245.
- [24] Paulraj AJ & Ng BN (1998) Space-time modems for wireless personal communications. *IEEE Pers Commun* 5(1):36–48.
- [25] Winters JH (1998) Smart antennas for wireless systems. *IEEE Commun Mag* 23–27.
- [26] Kohno R (1998) Spatial and temporal communication theory using adaptive antenna array. *IEEE Pers Commun* 5(1):28–35.
- [27] Paulraj AJ & Lindskog E (1998) Taxonomy of space-time processing for wireless networks. *IEE J Radar Sonar and Navig* 145(1).
- [28] Tsoulos GV (1999) Smart antennas for mobile communication systems: Benefits and challenges. *Electronics Commun Engineering J* 84–94.
- [29] Sheikh K, Gesbert D, Gore D & Paulraj A (1999) Smart antennas for broadband wireless access networks. *IEEE Commun Mag* 37(11):100–105.
- [30] Falconer D, Leganin A & Roy S (2000) Receiver spatial-temporal signal processing for broadband wireless systems. In: Proc. IEEE Int. Symp. Pers., Indoor, Mobile Radio Commun., London, UK.
- [31] Choi J & Choi S (2002) Diversity gain for CDMA systems equipped with antenna arrays. *IEEE Trans Veh Technol* submitted .

- [32] Jeng SS, Xu G, Lin HP & Vogel WJ (1995) Experimental study of antenna arrays in indoor wireless applications. In: Proc. Conf. Asilomar Sign., Syst., Comp., vol 2, 766–770.
- [33] Rapajic PB (1998) Information capacity of the space division multiple access mobile communication system. In: Proc. IEEE Int. Symp. Spread Spectrum Techniques and Applications, vol 3, 946–950.
- [34] Lotter MP & Rooyen PV (1998) An overview of space division multiple access techniques in cellular systems. In: Proc. Symp. South Afric. Commun. Sign. Process., 161–164.
- [35] Vornefeld U, Walke C & Walke B (1999) SDMA techniques for wireless ATM. IEEE Commun Mag 52–57.
- [36] Narula A, Lopez MJ, Trott MD & Wornell GW (1998) Efficient use of side information in multiple-antenna data transmission over fading channels. IEEE J Select Areas Commun 16(8):1423–1436.
- [37] Cover TM & Thomas JA (1998) Elements of Information Theory. John Wiley & Sons, New York, 2nd edn.
- [38] Foschini GJ (1996) Layered space-time architecture for wireless communications in a fading environment when using multi-element antennas. The Bell System Technical Journal 41–59.
- [39] Foschini GJ & Gans MJ (1998) On limits of wireless communications in a fading environment when using multiple antennas. Wireless Pers Commun Kluwer 6:311–335.
- [40] Telatar E (1999) Capacity of multi-antenna gaussian channels. European Trans Telecommun 10(6):585–595.
- [41] Winters JH, Salz J & Gitlin RD (1987) The impact of antenna diversity on the capacity of wireless communication systems. IEEE Trans Commun 42(2/3/4).
- [42] Raleigh GG & Cioffi JM (1998) Spatio-temporal coding for wireless communication. IEEE Trans Commun 46(3):357–366.
- [43] Ozarow LH, Shamai S & Wyner AD (1994) Information theoretic considerations for cellular mobile radio. IEEE Trans Veh Technol 43(2):359–378.
- [44] Biglieri E, Proakis JG & Shamai SS (1998) Fading channels: Information-theoretic and communications aspects. IEEE Trans Inform Theory 44(6):2619–2692.
- [45] Chuah CN, Tse D, Kahn JM & Valenzuela RA (2002) Capacity scaling in MIMO wireless systems under correlated fading. IEEE Trans Inform Theory 48(3).
- [46] Scaglione A & Sankoglu U (2001) Asymptotic capacity of space-time coding for arbitrary fading: A closed form expression using Girko’s law. In: Proc. IEEE Int. Conf. Acoust., Speech, Signal Processing, vol 4, 2509–2511.
- [47] Khalighi MA, Brossier JM, Jourdain G & Raouf K (2001) Water filling capacity of Rayleigh MIMO channels. In: Proc. IEEE Int. Symp. Pers., Indoor, Mobile Radio Commun., vol 1, 155–158.
- [48] Rapajic PB & Popescu D (2000) Information capacity of a random signature multiple-input multiple-output channel. IEEE Trans Commun 48(8).

- [49] Smith PJ & Shafi M (2002) On a Gaussian approximation to the capacity of wireless MIMO systems. In: Proc. IEEE Int. Conf. Commun., vol 1, 406–410.
- [50] Narula A, Trott MD & Wornell GW (1999) Performance limits of coded diversity methods for transmitter antenna arrays. *IEEE Trans Inform Theory* 45(7):2418–2433.
- [51] Alouini MS & Goldsmith A (1999) Capacity of Rayleigh fading channels under different adaptive transmission and diversity-combining techniques. *IEEE Trans Veh Technol* 48(4):1165–1181.
- [52] Ahmed W & McLane PJ (1999) Achievable performance over fading channels with antenna diversity. In: Proc. IEEE Wireless Commun. and Networking Conf., vol 1, 25–29.
- [53] Sandhu S, Nabar RU, Gore DA & Paulraj A (2000) Near-optimal selection of transmit antennas for a MIMO channel based on Shannon capacity. In: Proc. Conf. Asilomar Sign., Syst., Comp., vol 1, 567–571.
- [54] Gore D & Paulraj A (2002) Statistical MIMO antenna sub-set selection with space-time coding. In: Proc. IEEE Int. Conf. Commun., vol 1, 641–645.
- [55] Molish AF, Win MZ & Winters JH (2001) Capacity of MIMO systems with antenna selection. In: Proc. IEEE Int. Conf. Commun., vol 2, 570–574.
- [56] Blum RS & Winters JH (2002) An optimum MIMO with antenna selection. *IEEE Commun Lett* 6(8):322–324.
- [57] Caire G, Taricco G & Biglieri E (1999) Optimum power control over fading channels. *IEEE Trans Inform Theory* 45(5):1468–1489.
- [58] Knopp R & Caire G (1999) Power control schemes for TDD systems with multiple transmit and receive antennas. In: Proc. IEEE Global Telecommun. Conf., Rio de Janeiro, Brazil, 2326–2330.
- [59] Caire G, Taricco G & Biglieri E (1999) Optimum power control over fading channels. *IEEE Trans Inform Theory* 45(5):1468–1489.
- [60] Marzetta TL & Hochwald BM (1999) Capacity of a mobile multiple-antenna communication link in rayleigh flat fading. *IEEE Trans Inform Theory* 45(1):139–157.
- [61] Tse D & Zheng L (2000) Information theoretic limits for non coherent multi-antenna communications. In: Proc. IEEE Wireless Commun. and Networking Conf., 18–22.
- [62] Zheng L & Tse DNC (2001) The number of degrees of freedom in noncoherent block fading multiple antenna channel. In: Proc. IEEE Int. Symp. Inform. Theory, Washington DC, USA, 51.
- [63] Zheng L & Tse DNC (2002) Communication on the grassman manifold: A geometric approach to the noncoherent multiple-antenna channel. *IEEE Trans Inform Theory* 48(2):359–383.
- [64] Shiu DS, Foschini G, Gans M & Kahn JM (2000) Fading correlation and its effect on the capacity of multielement antenna systems. *IEEE Trans Commun* 48(3).
- [65] Driessen PD & Foschini GJ (1999) On the capacity formula for multiple input-output wireless channels. *IEEE Trans Commun* 47(2).

- [66] Catreux S, Kirlin RL & Driessen PF (1999) Enhanced capacity using adaptive transmission and receive diversity. In: Proc. IEEE Veh. Technol. Conf., vol 2, 1283–1287.
- [67] Morris M & Jensen MA (2002) The impact of array configuration on MIMO wireless channel capacity. In: Proc. Int. Symp. Antenn. Prop., vol 3, 214.
- [68] Jana R & Dey S (2000) Mobile capacity enhancement using unequally spaced antenna arrays. In: Proc. IEEE Veh. Technol. Conf., vol 2, 1215–1219.
- [69] Martin C & Ottersten B (2002) Analytic approximations of eigenvalue moments and mean channel capacity for MIMO channels. In: Proc. IEEE Int. Conf. Acoust., Speech, Signal Processing, vol 3, 2389–2392.
- [70] Spencer QH & Swindlehurst AL (2000) Some results on channel capacity when using multiple antennas. In: Proc. IEEE Veh. Technol. Conf., Tokyo, Japan.
- [71] Bolcskei H, Gesbert D & Paulraj AJ (2000) On the capacity of OFDM based multi-antenna systems. In: Proc. IEEE Int. Conf. Acoust., Speech, Signal Processing.
- [72] Bolcskei H, Gesbert D & Paulraj AJ (2002) On the capacity of OFDM based spatial multiplexing systems. *IEEE Trans Commun* 50(2):225–234.
- [73] Summers T & Wilson S (2002) Finite constellation capacity for space-time coding. In: Proc. Conf. Inform. Sciences Syst. (CISS), Princeton, USA.
- [74] Baltersee J, Fock G & Meyr H (2001) Achievable rate of MIMO channels with data-aided channel estimation and perfect interleaving. *IEEE J Select Areas Commun* 19(12):2358–2368.
- [75] Loyka S & Mosig J (2000) Channel capacity of N-antenna BLAST architecture. *Electron Lett* 36(7).
- [76] Loyka S (2001) Channel capacity of MIMO architecture using the exponential correlation matrix. *IEEE Commun Lett* 5(9):369–371.
- [77] Loyka S & Kouki A (2002) New compound upper bound on MIMO channel capacity. *IEEE Commun Lett* 6(3):96–98.
- [78] Yu K, Bengtsson M, Ottersten B, McNamara D, Karlsson P & Beach MA (2002) Modeling of wideband MIMO radio channels based on NLOS indoor measurements. *IEEE Trans Veh Technol* submitted .
- [79] Kermoal JP et al. (2000) Experimental investigation of multipath richness for multi-element transmit and receive antenna arrays. In: Proc. IEEE Veh. Technol. Conf., vol 3, 2004–2008.
- [80] Knudsen MB, Pedersen GF, Olsson BGH & Olesen K (2000) Mobile phone measurement including the antenna. In: Proc. IEEE Veh. Technol. Conf., vol 3, 2536–2540.
- [81] McNamara DP, Beach MA, Karlsson P & Fletcher PN (2000) Initial characterisation of multiple-input multiple-output channels for space-time communication. In: Proc. IEEE Veh. Technol. Conf., Tokyo, Japan, 1193–1197.
- [82] Martin CC, Winters JH & Sollenberg NR (2000) Multiple-input multiple-output radio channel measurements. In: Proc. IEEE Veh. Technol. Conf., Tokyo, Japan, 774–779.
- [83] Pedersen KI, Mogensen PE & Fleury BH (1997) Power azimuth spectrum in outdoor environments. *Electron Lett* 33(18):1583–1584.

- [84] Xu H, Gans M, Chiznik D, Ling J, Wolniansky P & Valenzuela R (2002) Spatial and temporal variations of MIMO channels and impacts on capacity. In: Proc. IEEE Int. Conf. Commun., vol 1, 262–266.
- [85] Molisch A, Steinbauer M, Toeltsch M, Bonek E & Thom RS (2002) Capacity of MIMO systems based on measured wireless channels. *IEEE J Select Areas Commun* 20(3):561–569.
- [86] Gesbert D, Bolcskei H, Gore D & Paulraj A (2000) MIMO wireless channels: Capacity and performance prediction. In: Proc. IEEE Global Telecommun. Conf., vol 2, 1083–1088.
- [87] Chizhik D, Foschini G, Gans M & Valenzuela R (2002) Keyholes, correlations, and capacities of multielement transmit and receive antennas. *IEEE Trans Wireless Commun* 1(2):361–368.
- [88] Heath Jr. RW & Paulraj A (1999) Multiple antenna arrays for transmitter diversity and space-time coding. In: Proc. IEEE Int. Conf. Commun., vol 1, 36–40.
- [89] Gorokhov A (2000) Transmit diversity versus SDMA: Analytic and numerical comparisons. In: Proc. IEEE Int. Conf. Commun., 1020–1024.
- [90] Blum RS, Winters JH & Sollenberg NR (2002) On the capacity of cellular systems with MIMO. *IEEE Commun Lett* 6(6):242–244.
- [91] Bauch G & Hagenauer J (2002) Smart versus dumb antennas - capacities and FEC performance. *IEEE Commun Lett* 6(2):55–57.
- [92] Viswanath P, Tse DNC & Laroia R (2002) Opportunistic beamforming using dumb antennas. *IEEE Trans Inform Theory* 48(6):1277–1294.
- [93] Berrou C, Glavieux A & Thitimajshima P (1993) Near Shannon limit error correcting coding and decoding. In: Proc. IEEE Int. Conf. Commun., Geneve, Switzerland, vol 2, 1064–1070.
- [94] Berrou C & Glavieux A (1996) Near optimum error correcting coding and decoding: Turbo codes. *IEEE Trans Commun* 44(10).
- [95] Robertson P (1994) Illuminating the structure of code and decoder of parallel concatenated recursive systematic (turbo) codes. In: Proc. IEEE Global Telecommun. Conf., vol 3, 1298–1303.
- [96] Hagenauer J & Papke L (1994) Decoding turbo codes with soft output Viterbi algorithms. In: Proc. IEEE Int. Symp. Inform. Theory, 163.
- [97] Benedetto S & Montorsi G (1995) Role of recursive convolutional codes in turbo codes. *Electron Lett* 31(11):858–859.
- [98] Battail G (1998) A conceptual framework for understanding turbo codes. *IEEE J Select Areas Commun* 16(2):245–254.
- [99] Elias P (1954) Error-free coding. *IEEE Trans Inform Theory* 4:29–37.
- [100] Hirasawa S, Kasahara M, Sugiyama Y & Namekawa T (1984) Modified product codes. *IEEE Trans Inform Theory* 30(2):299–306.
- [101] Forney GDJ (1966) *Concatenated Codes*. McGraw-Hill, Cambridge, MA, USA.
- [102] Lin S & Costello D (1983) *Error Control Coding*. Prentice-Hall, Englewood Cliffs, NJ, USA.

- [103] Orten P & Svensson A (1997) Sequential decoding in future mobile communications. In: Proc. IEEE Int. Symp. Pers., Indoor, Mobile Radio Commun.
- [104] Heegard C & Wicker SB (1999) Turbo Coding. Kluwer Academic Publishers, Boston/Dordrecht/London, 1st edn.
- [105] Vucetic B & Yuan J (2000) Turbo Codes: Principles and Applications. Kluwer Academic Publishers, 1st edn.
- [106] Sailing towards channel capacity (1998) Special issue on concatenated coding techniques and iterative decoding, IEEE J Select Areas Commun 16(2).
- [107] From theory to practice I (2001) Special issue on the turbo principle, IEEE J Select Areas Commun 19(5).
- [108] From theory to practice II (2001) Special issue on the turbo principle, IEEE J Select Areas Commun 19(9).
- [109] The 1st International Symposium on Turbo Codes and Related Topics (1997) ENST de Bretagne, Brest, France.
- [110] The 2nd International Symposium on Turbo Codes and Related Topics (2000) ENST de Bretagne, Brest, France.
- [111] Divsalar D, Dolinar S & Pollara F (1995) Transfer function bounds on the performance of turbo codes. TDA Prog Report 42 122 JPL Pasadena CA .
- [112] Perez L, Seghers J & Costello Jr. DJ (1996) A distance spectrum interpretation of turbo codes. IEEE Trans Inform Theory 42(6):1698–1709.
- [113] Benedetto S & Montorsi G (1996) Unveiling turbo codes: Some results on parallel concatenated coding schemes. IEEE Trans Inform Theory 42(2):409–428.
- [114] Duman TM & Salehi M (1998) New performance bounds for turbo codes. IEEE Trans Commun 46(6):717–723.
- [115] Sason I & Shamai S (2000) Improved upper bounds on the ML decoding error probability of parallel and serial concatenated turbo codes via ensemble distance spectrum. IEEE Trans Commun 46(1):24–47.
- [116] Babich F, Montorsi G & Vatta F (2000) Improved union bounds on turbo codes performance. IEE Proc 147(6):337–344.
- [117] Garello R, Pierleoni P & Benedetto S (2001) Computing the free distance of turbo codes and serially concatenated codes with interleavers: Algorithms and applications. IEEE J Select Areas Commun 19(5):800–812.
- [118] Al-Semari SA & Abulbashar M (1999) Exact calculation of the union bound for the performance of turbo codes over fading channels. In: Proc. IEEE Wireless Commun. and Networking Conf., vol 1, 457–460.
- [119] Divsalar D & Pollara F (1995) On the design of turbo codes. TDA Prog Report 42 123 JPL Pasadena CA .
- [120] Benedetto S & Montorsi G (1996) Design of parallel concatenated convolutional codes. IEEE Trans Commun 44(5):591–600.
- [121] Hall EK & Wilson SG (1998) Design and analysis of turbo codes on Rayleigh fading channels. IEEE J Select Areas Commun 16(2):160–174.

- [122] Leanderson CF, Hokfelt J, Edfors O & Maseng T (2000) On the design of low rate turbo codes. In: Proc. IEEE Veh. Technol. Conf., Tokyo, Japan.
- [123] MacWilliams FJ & Sloane NJ (1993) The Theory of Error-Correcting Codes. North Holland.
- [124] Benedetto S, Garelo R & Montorsi G (1998) A search for good convolutional codes to be used in the construction of turbo codes. IEEE Trans Commun 46(9):1101–1105.
- [125] Yuan J, Vucetic B & Feng W (1999) Combined turbo codes and interleaving design. IEEE Trans Commun 47(4):484–487.
- [126] Barbulescu AS & Pietrobon SS (1994) Interleaving design for turbo codes. Electron Lett 30(25):2107–2108.
- [127] Divsalar D & Pollara F (1995) Multiple turbo codes for deep-space communications. TDA Prog Report 42 121 JPL Pasadena CA .
- [128] Daneshgaran F & Mondin M (1997) Design of interleavers for turbo codes based on a cost function. In: Proc. Int. Symp. Turbo Cod. Related Topics, Brest, France, 255–258.
- [129] Hokfelt J & Maseng T (1997) Methodical interleaver design for turbo codes. In: Proc. Int. Symp. Turbo Cod. Related Topics, Brest, France, 212–215.
- [130] Andersen JD & Zyablov VV (1997) Interleaving design for turbo coding. In: Proc. Int. Symp. Turbo Cod. Related Topics, Brest, France.
- [131] Hokfelt J, Edfors O & Maseng T (2001) On the theory and performance of trellis termination methods for turbo codes. IEEE J Select Areas Commun 19(5):838–847.
- [132] Barbulescu AS & Pietrobon SS (1995) Terminating the trellis of turbo-codes in the same state. Electron Lett 31(1):22–23.
- [133] Dijk MV, Egner S, Motwani R & Koppelaar A (2000) Simultaneous zero-tailing of parallel concatenated codes. In: Proc. IEEE Int. Symp. Inform. Theory, Sorrento, Italy, 368.
- [134] Jung P & Nashed M (1994) Performance evaluation of turbo codes for short frame transmission systems. Electron Lett 30(2):111–113.
- [135] Jung P (1996) Comparison of turbo-code decoders applied for short frame transmission systems. IEEE J Select Areas Commun 14(3):530–534.
- [136] Salah MM, Raines RA, Temple MA & Bailey TG (1999) Approach for deriving performance bounds of punctured turbo codes. Electron Lett 35(25):2191–2192.
- [137] Mugaibel AH & Kousa MA (2000) Evaluation of transfer functions for punctured turbo codes. Electron Lett 36(9):805–807.
- [138] Mielczarek B (2002) Turbo codes and channel estimation in wireless systems. Ph.D. Thesis, Chalmers University of Technology, Goteborg, Sweden.
- [139] Forney GD (1973) The Viterbi algorithm. Proc IEEE 61(3):268–278.
- [140] Bahl LR, Cocke J, Jelinek F & Raviv J (1974) Optimal decoding of linear codes for minimizing symbol error rate. IEEE Trans Inform Theory 20(2):284–287.

- [141] Benedetto S, Divsalar D, Montorsi G & Pollara F (1996) Soft-output decoding algorithms in iterative decoding of turbo codes. TDA Prog Report 42 124 JPL Pasadena CA .
- [142] Chang Y (1996) Parallel decoding of turbo codes. *Electron Lett* 32(13):1188–1189.
- [143] Benedetto S, Divsalar D, Montorsi G & Pollara F (1996) A soft-input soft-output maximum a posteriori (MAP) module to decode parallel and serial concatenated codes. TDA Prog Report 42 127 JPL Pasadena CA .
- [144] Benedetto S, Divsalar D, Montorsi G & Pollara F (1997) A soft-input soft-output maximum APP module for iterative decoding of concatenated codes. *IEEE Commun Lett* 1(1):22–24.
- [145] Benedetto S & Montorsi G (1997) Soft-input soft-output building blocks to construct and iteratively decode code networks. In: *Proc. IEEE Int. Symp. Inform. Theory*, Ulm, Germany, 492.
- [146] Robertson P, Hoeher P & Villebrun E (1997) Optimal and sub-optimal maximum a posteriori algorithms suitable for turbo decoding. *European Trans Telecommun* 8(2):119–125.
- [147] Valenti M (1999) Iterative detection and decoding for wireless communications. Ph.D. Thesis, Virginia Tech, Virginia, USA.
- [148] Barbulescu SA (1996) Iterative decoding of turbo codes and other concatenated codes. Ph.D. Thesis, University of South Australia.
- [149] Worm A, Hoeher P & Wehn N (2000) Turbo-decoding without SNR estimation. *IEEE Commun Lett* 4(6):193–195.
- [150] Hagenauer J & Hoeher P (1989) A viterbi algorithm with soft-decision outputs and its applications. In: *Proc. IEEE Global Telecommun. Conf.*, Dallas, USA, vol 3, 1680–1686.
- [151] Berrou C, Adde P, Angui E & Faudeil S (1993) A low complexity soft-output Viterbi architecture. In: *Proc. IEEE Int. Conf. Commun.*, Geneve, Switzerland, vol 2, 737–740.
- [152] Papke L & Robertson P (1996) Improved decoding with the SOVA in a parallel concatenated turbo-code scheme. In: *Proc. IEEE Int. Conf. Commun.*, Dallas, TX, USA, 102–106.
- [153] Nordman R & Komulainen P (2000) A turbo decoder with the Berrou SOVA algorithm. In: *Proc. Int. Symp. Turbo Cod. Related Topics*, Brest, France, 299–302.
- [154] Amat AG, Montorsi G & Benedetto S (2002) New high-rate convolutional codes for concatenated schemes. In: *Proc. IEEE Int. Conf. Commun.*, New York, USA, 1661–1666.
- [155] Benedetto S, Divsalar D, Montorsi G & Pollara F (1998) Self-concatenated trellis coded modulation with self iterative decoding. In: *Proc. IEEE Int. Symp. Inform. Theory*, 585–591.
- [156] Benedetto S, Divsalar D, Montorsi G & Pollara F (1996) Serial concatenation of interleaved codes: Performance analysis, design and iterative decoding. TDA Prog Report 42 126 JPL Pasadena CA .

- [157] Benedetto S, Divsalar D, Montorsi G & Pollara F (1997) Design of serially concatenated interleaved codes. In: Proc. IEEE Int. Conf. Commun., Montreal, Canada, 710–714.
- [158] Benedetto S, Divsalar D, Montorsi G & Pollara F (1997) Serial concatenated trellis coded modulation with iterative decoding. In: Proc. IEEE Int. Symp. Inform. Theory, Ulm, Germany, 8.
- [159] Benedetto S, Divsalar D, Montorsi G & Polara F (1998) Serial concatenation of interleaved codes: Performance analysis, design, and iterative decoding. *IEEE Trans Inform Theory* 44(3):909–926.
- [160] Ogiwara H & Bajo VB (1999) Iterative decoding of serially concatenated punctured trellis-coded modulation. In: Proc. IEEE Int. Conf. Commun., Vancouver, Canada, 1167–1171.
- [161] Rahman MG, Rajatheva RMAP & Ahmed KM (1999) Performance of serial concatenated convolutional code in Rayleigh multipath fading channel. In: Proc. IEEE Veh. Technol. Conf., Houston, USA, 2510–2514.
- [162] Fragouli C & Polydoros A (2002) Symbol-interleaved serially concatenated trellis codes. In: Proc. Conf. Inform. Sciences Syst. (CISS).
- [163] Divsalar D, Dolinar S & Pollara F (2000) Serial turbo trellis coded modulation with rate-1 inner code. In: Proc. IEEE Int. Symp. Inform. Theory, Sorrento, Italy, 100.
- [164] Benedetto S, Divsalar D, Montorsi G & Pollara F (1998) Analysis, design, and iterative decoding of double serially concatenated codes with interleavers. *IEEE J Select Areas Commun* 16:231–244.
- [165] Pyndiah R (1998) Near optimal decoding of product codes: Block turbo codes. *IEEE Trans Commun* 46:1003–1010.
- [166] Viterbi AJ (1991) Wireless digital communication: A view based on three lessons learned. *IEEE Commun Mag* 29(9):33–36.
- [167] Hagenauer J (1997) The turbo principle: Tutorial introduction and state of the art. In: Proc. Int. Symp. Turbo Cod. Related Topics, Brest, France, vol 1, 1–11.
- [168] Li X & Ritcey JA (1997) Bit-interleaved coded modulation with iterative decoding. *IEEE Commun Lett* 1(6):169–171.
- [169] Li X & Ritcey JA (1999) Trellis-coded modulation with bit interleaving and iterative decoding. *IEEE J Select Areas Commun* 17(4):715–724.
- [170] Li X & Ritcey JA (1998) Bit interleaved coded modulation with iterative decoding using soft feedback. *Electron Lett* 34(10):942–943.
- [171] Narayanan KR & Stueber GL (1999) A serial concatenation approach to iterative demodulation and decoding. *IEEE Trans Commun* 47(7):956–961.
- [172] Douillard C, Jezequel CM, Picart A, Didier P & Glavieux A (1995) Iterative correction of intersymbol interference: Turbo-equalisation. *European Trans Telecommun* 6(5):507–511.
- [173] Glavieux A, Laot C & Labat J (1997) Turbo equalization over a frequency selective channel. In: Proc. Int. Symp. Turbo Cod. Related Topics, Brest, France, vol 1, 96–102.

- [174] Anastasopoulos A & Chugg KM (1998) Iterative equalization/decoding of TCM for frequency-selective fading channels. In: Proc. Conf. Asilomar Sign., Syst., Comp., 177–181.
- [175] Bauch G & Franz V (1998) Iterative equalization and decoding for the GSM system. In: Proc. IEEE Veh. Technol. Conf., Ottawa, Canada, 2262–2266.
- [176] Magniez P & Duhamel P (1999) Turbo-equalization applied to trellis-coded-modulations. In: Proc. IEEE Veh. Technol. Conf., Amsterdam, Netherlands, 2556–2560.
- [177] Roumy A, Fijalkow I & Pirez D (1999) Joint equalization and decoding: Why choose the iterative solution? In: Proc. IEEE Veh. Technol. Conf., 2989–2993.
- [178] Strauch P, Luschi C, Sandell M & Yan R (1999) Turbo equalization for an 8-PSK modulation scheme in a mobile TDMA communication system. In: Proc. IEEE Veh. Technol. Conf., 1605–1609.
- [179] Narayanan KR, Dasgupta U & Lu B (2000) Low complexity turbo equalization with binary precoding. In: Proc. IEEE Global Telecommun. Conf., San Francisco, USA.
- [180] Tuchler M, Koetter R & Singer A (2000) Iterative correction of ISI via equalization and decoding with priors. In: Proc. IEEE Int. Symp. Inform. Theory, Sorrento, Italy, 100.
- [181] Veselinovic N, Henttu P, Siltala S, Tujkovic D & Juntti M (2001) Wideband interference suppression in turbo coded DS/FH spread spectrum system. In: Proc. IEEE Int. Conf. Commun.
- [182] Moher M (1998) An iterative multiuser decoder for near-capacity communications. *IEEE Trans Commun* 46(7):870–880.
- [183] Moher M & Guinand P (1998) An iterative algorithm for asynchronous coded multiuser detection. *IEEE Commun Lett* 2(8):229–231.
- [184] Valenti MC & Woerner BD (1998) Combined multiuser reception and channel decoding for TDMA cellular systems. In: Proc. IEEE Veh. Technol. Conf., Ottawa, Canada, 1915–1919.
- [185] Schlegel C, Alexander PD & Roy S (1998) Coded asynchronous CDMA and its efficient detection. *IEEE Trans Inform Theory* 44(7):2837–2847.
- [186] Gamal HE & Geraniotis E (2000) Iterative multiuser detection for coded CDMA signals in AWGN and fading channels. *IEEE J Select Areas Commun* 18(1):30–41.
- [187] Reed MC, Schlegel CB, Alexander P & Asenstorfer JA (1998) Iterative multiuser detection for CDMA with FEC: Near-single-user performance. *IEEE Trans Commun* 46(12):1693–1699.
- [188] Alexander PD, Reed MC, Asenstorfer JA & Schlegel CB (1999) Iterative multiuser interference reduction: Turbo CDMA. *IEEE Trans Commun* 47(7):1008–1014.
- [189] Honig ML, Woodward G & Alexander PD (2000) Adaptive multiuser parallel-decision-feedback with iterative decoding. In: Proc. IEEE Int. Symp. Inform. Theory, Sorrento, Italy, 335.
- [190] Damnjanovic AD & Vojcic BR (2001) Iterative multiuser detection. *KICS J Commun Netw* 3(3):211–218.

- [191] Davis LM, Collings IB & Hoeher P (2001) Joint MAP equalization and channel estimation for frequency-selective and frequency-flat fast-fading channels. *IEEE Trans Commun* 49(12):2106–2114.
- [192] Mielczarek B & Svensson A (2002) Improved iterative channel estimation and turbo decoding over flat-fading channels. In: *Proc. IEEE Veh. Technol. Conf.*
- [193] Hagenauer J & Stockhammer T (1999) Channel coding and transmission aspects for wireless multimedia. *Proc IEEE* 87(10):1764–1777.
- [194] Goff SL, Glavieux A & Berrou C (1994) Turbo-codes and high spectral efficiency modulation. In: *Proc. IEEE Int. Conf. Commun.*, vol 2, 645–649.
- [195] Wachsmann U & Huber J (1995) Power and bandwidth efficient digital communication using turbo codes in multilevel codes. *European Trans Telecommun* 6(5).
- [196] Robertson P & Woerz T (1995) Coded modulation scheme employing turbo codes. *Electron Lett* 31:1546–1547.
- [197] Benedetto S, Divsalar D, Montorsi G & Polara F (1995) Bandwidth efficient parallel concatenated coding scheme. *Electron Lett* 31(24):2067–2069.
- [198] Goff SL (2000) Performance of bit-interleaved turbo-coded modulations on Rayleigh fading channels. *Electron Lett* 36(8):731–733.
- [199] Goff SL & Al-Ayyan FO (2001) Design of a bit-interleaved turbo-coded modulations. *Electron Lett* 37(16):1030–1031.
- [200] Raphaelli D & Gurevitz A (2002) Constellation shaping for pragmatic turbo coded modulation. *Electron Lett* 38(14):717–719.
- [201] Olivieri S & Martini MG (2001) Dynamic bit-interleaved turbo-coded modulation for unequal error protection. In: *Proc. IEEE Global Telecommun. Conf.*, 3267–3271.
- [202] Viterbi AJ, Wolf JK, Zehavi E & Padovani R (1989) A pragmatic approach to trellis-coded modulation. *IEEE Commun Mag* 11–19.
- [203] Zehavi E (1992) 8-PSK trellis codes for a Rayleigh channel. *IEEE Trans Commun* 40(5):873–884.
- [204] Caire G, Taricco G & Biglieri E (1998) Bit-interleaved coded modulation. *IEEE Trans Inform Theory* 44(3):927–946.
- [205] Herzberg H (1998) Multilevel turbo coding with short interleavers. *IEEE J Select Areas Commun* 16(2):303–309.
- [206] Burr A (1997) Multilevel turbo-coded modulation: Performance bounds. In: *Proc. Int. Symp. Turbo Cod. Related Topics.*
- [207] Imai H & Hirakawa S (1977) A new multilevel coding method using error correcting codes. *IEEE Trans Inform Theory* 23(3):371–377.
- [208] Calderbank AR (1989) Multilevel codes and multistage decoding. *IEEE Trans Commun* 37(3):222–229.
- [209] Seshadri N & Sundberg CEW (1993) Multilevel trellis coded modulations for the Rayleigh fading channel. *IEEE Trans Commun* 41(9)(9):1300–1310.
- [210] Robertson P & Woerz T (1998) Bandwidth-efficient turbo trellis-coded modulation using punctured component codes. *IEEE J Select Areas Commun* 16(2):206–218.

- [211] Blackert WJ & Wilson SG (1996) Turbo trellis coded modulation. In: Proc. Conf. Inform. Sciences Syst. (CISS), Princeton University, Princeton, NJ.
- [212] Ungerboeck G (1982) Channel coding with multilevel/phase signals. *IEEE Trans Inform Theory* 28.
- [213] Ungerboeck G (1987) Trellis-coded modulation with redundant signal sets part I: Introduction. *IEEE Commun Mag* 25(2):5–21.
- [214] Ungerboeck G (1982) Channel coding with multilevel/phase signals. *IEEE Trans Inform Theory* 28(1):55–67.
- [215] Biglieri E, Divsalar D, Mclane & Simon M (1991) Introduction to Trellis-Coded Modulation with Applications. Macmillian Publishing Co.
- [216] Jamali SH & Lengoc T (1994) Coded-modulation techniques for fading Channels. Kluwer Academic Publishers.
- [217] Anderson JB & Svensson A (2002) Coded Modulation Systems. Kluwer Academic/Plenum Publishers.
- [218] Benedetto S, Marsan MA, Albertengo G & Giachin E (1988) Combined coding and modulation: Theory and applications. *IEEE Trans Inform Theory* 34(2):223–236.
- [219] Divsalar D & Simon MK (1988) Multiple trellis coded modulation (MTCM). *IEEE Trans Commun* 36(4):410–419.
- [220] Divsalar D & Simon MK (1988) The design of trellis coded MPSK for fading channels: Performance criteria. *IEEE Trans Commun* 36(9):1004–1012.
- [221] Divsalar D & Simon MK (1988) The design of trellis coded MPSK for fading channels: Set partitioning for optimum code design. *IEEE Trans Commun* 36(9):1013–1021.
- [222] Schlegel C & Costello DJ (1989) Bandwidth efficient coding for fading channels: Code construction and performance analysis. *IEEE J Select Areas Commun* 7(9):1356–1368.
- [223] Du J, Vucetic B & Zhang L (1995) Construction of new MPSK trellis codes for fading channels. *IEEE Trans Commun* 43(2/3/4):776–784.
- [224] Ogiwara H & Yano M (1998) Improvement of turbo trellis-coded modulation system. *IEICE Trans Fundamentals Elec Commun and Comp Sc* E81-A(10):2040–2046.
- [225] Benedetto S, Divsalar D & Pollara GMF (1996) Parallel concatenated trellis coded modulation. In: Proc. IEEE Int. Conf. Commun., 974–978.
- [226] Fragouli C & Wesel RD (2001) Bit vs. symbol interleaving for parallel concatenated trellis coded modulation. In: Proc. IEEE Global Telecommun. Conf., vol 2, 931–935.
- [227] Scanavino B, Montorsi G & Benedetto S (2001) Convergence properties of iterative decoders working on bit and symbol level. In: Proc. IEEE Global Telecommun. Conf., vol 2, 1037–1041.
- [228] Grant A (2001) Convergence of non-binary iterative decoding. In: Proc. IEEE Global Telecommun. Conf., 1058–1062.
- [229] Fragouli C & Wesel RD (2001) Turbo-encoder design for symbol-interleaved parallel concatenated trellis-coded modulation. *IEEE Trans Commun* 49(3):425–435.

- [230] Ha NH & Rajatheva RMAP (1999) Performance of turbo trellis-coded modulation (T-TCM) on frequency-selective rayleigh fading channels. In: Proc. IEEE Int. Conf. Commun., 88–92.
- [231] Yuan J, Feng W & Vucetic B (2000) Turbo trellis coded modulation for fading channels. In: Proc. IEEE Veh. Technol. Conf.
- [232] Papadimitriou PD & Varshney P (2001) Turbo coded modulation for high-throughput TDMA systems. In: Proc. IEEE Veh. Technol. Conf., Rhodes.
- [233] Aydinlik M & Salehi M (2002) 16-QAM turbo coded modulation for the Gilbert-Elliott channel model. In: Proc. Conf. Inform. Sciences Syst. (CISS).
- [234] Vishwanath S & Goldsmith A (2000) BER bounds for turbo coded modulation and their application to adaptive modulation. In: Proc. IEEE Int. Symp. Inform. Theory, Sorrento, Italy, 193.
- [235] Vishwanath S & Goldsmith A (2001) Adaptive turbo coded modulation for flat fading channels. IEEE Trans Commun submitted .
- [236] Duman T & Salehi M (1999) Performance bounds for turbo-coded modulation systems. IEEE Trans Commun 47(4):511–521.
- [237] Ohtsuki T & Kahn JM (1999) Transfer function bounds on performance of turbo codes for M-ary orthogonal signals. In: Proc. IEEE Global Telecommun. Conf., 515–519.
- [238] Ohtsuki T & Kahn JM (2000) Transfer function bounds on performance of binary turbo-coding followed by M-ary orthogonal signal mapping through interleaver. In: Proc. IEEE Int. Conf. Commun., 623–627.
- [239] Duman T & Salehi M (1999) The union bound for turbo-coded modulation systems over fading channels. IEEE Trans Commun 47(10):1495–1502.
- [240] Ogiwara H, Mizutome A & Koike K (2000) Performance evaluation of parallel concatenated TCM. In: Proc. Int. Symp. Turbo Cod. Related Topics.
- [241] Tarokh V, Alamouti SM & Poon P (1998) New detection schemes for transmit diversity with no channel estimation. In: Proc. IEEE Int. Conf. Universal Pers. Commun., Florence, Italy, vol 2, 917–920.
- [242] Tarokh V & Jafarkhani H (2000) A differential detection scheme for transit diversity. IEEE J Select Areas Commun 18(7):1043–1047.
- [243] Hochwald BM & Marzetta TL (2000) Unitary space-time modulation for multiple-antenna communications in Rayleigh flat fading. IEEE Trans Inform Theory 46(2):543–563.
- [244] Grant A & Schlegel C (2001) Differential turbo space-time coding. In: Proc. IEEE Inf. Th. Workshop, Cairns, Australia, 467–471.
- [245] Steiner A, Peleg M & Shamai S (2001) Turbo coded space-time unitary matrix differential modulation. In: Proc. IEEE Veh. Technol. Conf., Rhodes, Greece, vol 2, 1352–1356.
- [246] Bahceci I & Duman TM (2001) Combined turbo coding and unitary space-time modulation. In: Proc. IEEE Int. Symp. Inform. Theory, Washington DC, USA, 106.

- [247] Gozali B et al. (2001) Virginia tech space-time advanced radio (VT-STAR). In: Proc. Conf. Radio & Wireless Commun., 227–231.
- [248] Borran J, Sabharwal A, Aazhang B & Johnson D (2002) On design criteria and construction of non-coherent space-time constellations. In: Proc. IEEE Int. Symp. Inform. Theory, Lausanne, Switzerland, 74.
- [249] Barbarossa S & Scaglione A (1999) Optimal precoding for transmissions over linear time-varying channels. In: Proc. IEEE Global Telecommun. Conf., Rio de Janeiro, Brasil, 2545–2549.
- [250] Kim J & Cioffi JM (2000) Spatial multiuser access with antenna diversity using singular value decomposition. In: Proc. IEEE Int. Conf. Commun., New Orleans, USA, vol 2, 1253–1257.
- [251] Lai SK, Cheng RSK, Letaief KB & Murch RD (1999) Adaptive trellis coded MQAM and power optimization for OFDM transmission. In: Proc. IEEE Veh. Technol. Conf., Houston, USA, 290–294.
- [252] Myers GK & Wilson SG (2002) Concatenated space-time coding with transmitter precoloring. In: Proc. Conf. Inform. Sciences Syst. (CISS), Princeton, USA.
- [253] Siwamogsatham S, Fitz MP & Grimm JH (2002) A new view of performance analysis of transmit diversity schemes in correlated Rayleigh fading. *IEEE Trans Inform Theory* 48(4):950–956.
- [254] Tarokh V, Seshadri N & Calderbank AR (1998) Space-time codes for high data rate wireless communication: Performance criterion and code construction. *IEEE Trans Inform Theory* 44(2)(2):744–765.
- [255] Guey JC, Fitz MP, Bell MR & Kuo WY (1996) Signal design for transmitter diversity wireless communication systems over rayleigh fading channels. In: Proc. IEEE Veh. Technol. Conf., 136–140.
- [256] Guey JC, Fitz MP, Bell MR & Kuo WY (1999) Signal design for transmitter diversity wireless communication systems over rayleigh fading channels. *IEEE Trans Commun* 47(4):527–537.
- [257] Bolcskei H & Paulraj AJ (2000) Performance of space-time codes in the presence of spatial fading correlation. In: Proc. Conf. Asilomar Sign., Syst., Comp., vol 1, 687–693.
- [258] Uysal M & Georghiadis CN (1999) Effect of spatial fading correlation on performance of space-time codes. *Electron Lett* 37(3):181–183.
- [259] Damen MO, Abdi AA & Kaveh M (2001) On the effect of correlated fading on several space-time coding and detection schemes. In: Proc. IEEE Veh. Technol. Conf., Rhodes, Greece, 13–16.
- [260] Kse C & Wesel R (2001) Code design metrics for space-time systems under arbitrary fading. In: Proc. IEEE Int. Conf. Commun., Helsinki, Finland.
- [261] Chen Z, Yuan J & Vucetic B (2001) Improved space-time trellis coded modulation scheme on slow Rayleigh fading channels. *Electron Lett* 37(7):440–441.
- [262] Tao M & Cheng RS (2001) Improved design criteria and new trellis codes for space-time coded modulation in slow flat fading channels. *IEEE Commun Lett* 5(7):313–315.

- [263] Biglieri E, Taricco G & Tulino A (2002) Performance of space-time codes for a large number of antennas. *IEEE Trans Inform Theory* 48(7):1794–1803.
- [264] Ionescu DM (1999) New results on space-time code design criteria. In: *Proc. IEEE Wireless Commun. and Networking Conf.*, 684–687.
- [265] Ionescu DM, Mulkavilli K, Yan Z & Lilleberg J (2001) Improved 8- and 16-state space-time codes for 4PSK with two transmit antennas. *IEEE Commun Lett* 5(7):301–303.
- [266] Wittneben A (1993) A new bandwidth efficient transmit antenna modulation diversity scheme for linear digital modulation. In: *Proc. IEEE Int. Conf. Commun.*, vol 3, 1630–1634.
- [267] Seshadri N & Winters JH (1993) Two signaling schemes for improving the error performance of frequency-division-duplex (FDD) transmission systems using transmitter antenna diversity. In: *Proc. IEEE Veh. Technol. Conf.*, Secaucus, USA, 508–511.
- [268] Winters JH (1998) The diversity gain of transmit diversity in wireless systems with rayleigh fading. *IEEE Trans Veh Technol* 47(1):119–123.
- [269] Li S, Tao X, Wang W, Zhang P & Han C (2000) Generalized delay diversity code: A simple and powerful space-time coding scheme. In: *Proc. Conf. ICCT*, 1697–1703.
- [270] Naguib AF, Tarokh V, Seshadri N & Calderbank AR (1998) A space-time coding modem for high-data-rate wireless communications. *IEEE J Select Areas Commun* 16(8):1459–1478.
- [271] Tarokh V, Naguib A, Seshadri N & Calderbank AR (1999) Space-time codes for high data rate wireless communication: Performance criteria in the presence of channel estimation errors, mobility, and multiple paths. *IEEE Trans Commun* 47(2)(2):199–207.
- [272] Baro S, Bauch G & Hansmann A (2000) Improved codes for space-time trellis-coded modulation. *IEEE Commun Lett* 4(1):20–22.
- [273] Grimm J, Fitz MP & Krogmeier JV (1998) Further results on space-time coding for Rayleigh fading. In: *Proc. Annual Allerton Conf. Commun., Control, Computing, Allerton House, Monticello, USA.*
- [274] Chen Z, Yuan J & Vucetic B (2001) An improved space-time trellis coded modulation scheme on slow Rayleigh fading channel. In: *Proc. IEEE Int. Conf. Commun.*
- [275] Zhou G, Wang Y, Zhang Z & Chugg KM (2001) On space-time convolutional codes for PSK modulation. In: *Proc. IEEE Int. Conf. Commun.*
- [276] Mulkavilli KK, Ionescu M & Aazhang B (2000) Design of space-time codes with optimal coding gain. In: *Proc. IEEE Int. Symp. Pers., Indoor, Mobile Radio Commun.*, London, UK.
- [277] Chen Z, Vucetic B, Yuan J & Lo KL (2001) Space-time trellis codes for 4-psk with three and four transmit antennas in quasi-static flat fading channels. *IEEE Commun Lett* .
- [278] Chen Z, Vucetic B, Yuan J & Lo KL (2002) Space-time trellis codes for 8-PSK with two, three, four transmit antennas in quasi static flat fading channels. *Electron Lett* 38(10):462–464.

- [279] Safar Z & Liu KJR (2001) Systematic space-time trellis code design for an arbitrary number of transmit antennas. In: Proc. IEEE Veh. Technol. Conf., Rhodes, Greece, 8–12.
- [280] Firmanto W, Yuan J & Vucetic B (2000) Space-time trellis coded modulation for fast fading channels. In: Proc. IEEE Int. Symp. Inform. Theory and its Applications, Honolulu, USA.
- [281] Zummo SA & Al-Semari SA (2000) Space-time coded QPSK for rapid fading channels. In: Proc. IEEE Int. Symp. Pers., Indoor, Mobile Radio Commun., London, UK.
- [282] Firmanto W & Yuan BVJ (2001) Space-time TCM with improved performance on fast fading channels. *IEEE Commun Lett* 5(4):154–156.
- [283] Pereira A & Carrasco RA (2001) Space-time ring TCM codes for QPSK on time-varying fast fading channels. *Electron Lett* 37(15):961–962.
- [284] Safar Z & Liu KJR (2002) Space-time trellis code construction for fast fading channels. In: Proc. IEEE Int. Conf. Commun., New York, USA.
- [285] Benedetto S, Mondin M & Montorsi G (1994) Performance evaluation of trellis-coded modulation schemes. *Proc IEEE* 82(6):833–855.
- [286] Hammons AR & Gamal HE (2000) On the theory of space-time codes for PSK modulation. *IEEE Trans Inform Theory* 46(2):524–542.
- [287] Rosiers AP & Siegel P (2000) On performance bounds for space-time coded modulation on fading channels. In: Proc. IEEE Int. Symp. Inform. Theory and its Applications, Honolulu, Hawaii, USA.
- [288] Aktas D & Fitz M (2000) Computing the distance spectra of space-time trellis codes. In: Proc. IEEE Wireless Commun. and Networking Conf., 51–55.
- [289] Kucukyavuz D & Fitz M (1999) New views of transfer function based performance analysis of coded modulations. In: Proc. Conf. Asilomar Sign., Syst., Comp., 42–46.
- [290] Uysal M & Georghiades CN (2000) Error performance analysis of space-time codes over Rayleigh fading channels. In: Proc. IEEE Veh. Technol. Conf.
- [291] Simon M (2001) Evaluation of average bit error probability for space-time coding based on a simpler exact evaluation of pairwise error probability. *KICS J Commun Netw* 3(3):257–264.
- [292] Chiani M, Conti A & Tralli V (2001) A pragmatic approach to space-time coding. In: Proc. IEEE Int. Conf. Commun.
- [293] Taricco G & Biglieri E (2002) Exact pairwise error probability of space-time codes. *IEEE Trans Inform Theory* 48(2):510–513.
- [294] Miller SL & Bouzekri H (2001) Space-time code performance analysis for quasi-static fading channels. In: Proc. IEEE Int. Symp. Inform. Theory, Washington DC, USA, 83.
- [295] Blum RS (1999) New analytical tools for design space-time convolutional codes. In: Proc. Conf. Inform. Sciences Syst. (CISS).
- [296] Blum RS (2002) Some analytical tools for the design of space-time convolutional codes. *IEEE Trans Commun* 50(10):1593–1599.

- [297] Yan Q & Blum RS (2000) Optimum space-time convolutional codes. In: Proc. IEEE Wireless Commun. and Networking Conf.
- [298] Gamal HE & Hammons ARJ (2002) On design and performance of algebraic space-time codes for BPSK and QPSK modulation. *IEEE Trans Commun* 50(6):907–913.
- [299] Liu Y, Fitz MP & Takeshita OY (2000) A rank criterion for QAM space-time codes. In: Proc. IEEE Int. Symp. Inform. Theory, Sorrento, Italy, 314.
- [300] Stefanov A (2002) General design (rank) criteria for QAM space-time codes over block fading channels. In: Proc. Conf. Inform. Sciences Syst. (CISS), Princeton, USA.
- [301] Lin X & Blum RS (2002) Systematic design of space-time codes employing multiple trellis coded modulation. *IEEE Trans Commun* 50(4):608–615.
- [302] Zummo SA & Al-Semari SA (2000) A decoding algorithm for I-Q space-time coded systems in fading environments. In: Proc. IEEE Veh. Technol. Conf., Tokyo, Japan, 331–335.
- [303] Boutros J, Boixadera F & Lamy C (2000) Bit-interleaved coded modulations for multiple-input multiple-output channels. In: Proc. IEEE Int. Symp. Spread Spectrum Techniques and Applications, New Jersey, USA, 123–126.
- [304] Tonello AM (2000) Space-time bit-interval coded modulation with an iterative decoding strategy. In: Proc. IEEE Veh. Technol. Conf., Tokyo, Japan.
- [305] Tonello AM (2000) Space-time bit-interval coded modulation over frequency selective fading channels with iterative decoding. In: Proc. IEEE Global Telecommun. Conf., San Francisco.
- [306] Tonello AM (2001) On turbo equalization of interleaved space-time codes. In: Proc. IEEE Veh. Technol. Conf., 887–891.
- [307] Muharemovic T, Gatherer A, Ebel W, Hosur S & Huang DHE (2001) Space-time codes with bit interleaving. In: Proc. IEEE Global Telecommun. Conf., Texas, USA.
- [308] Yan Q & Blum RS (2001) Robust space-time block coding for rapid fading channels. In: Proc. IEEE Global Telecommun. Conf., 460–464.
- [309] Bevan D & Tanner R (1999) Performance comparison of space-time coding techniques. *Electron Lett* 35(20):1707–1708.
- [310] Gamal H & Stefanov RHA (2002) Algebraic space-time overlays for convolutionally coded systems. In: Proc. IEEE Int. Symp. Pers., Indoor, Mobile Radio Commun., Lisboa, Portugal.
- [311] Sykora J (2001) Constant envelope space-time modulation trellis code design for Rayleigh flat fading channel. In: Proc. IEEE Global Telecommun. Conf., Texas, USA.
- [312] Naguib AF & Seshadri N (2000) MLSE and equalization of space-time coded signals. In: Proc. IEEE Veh. Technol. Conf., Tokyo, Japan.
- [313] Naguib AF (2000) On the matched filter bound of transmit diversity techniques. In: Proc. IEEE Global Telecommun. Conf., San Francisco, USA.
- [314] Al-Dhahir N (2001) Overview of equalization schemes for space-time-coded transmission with application to EDGE. In: Proc. IEEE Veh. Technol. Conf., vol 2, 1053–1057.

- [315] Al-Dhahir N (2001) Single-carrier frequency-domain equalization for space-time-coded transmissions over broadband wireless channels. In: Proc. IEEE Int. Symp. Pers., Indoor, Mobile Radio Commun., 143–146.
- [316] Al-Dhahir N (2002) Overview and comparison of different equalization schemes for space-time coded signals with application to EDGE. *IEEE Trans Signal Processing* 50(10).
- [317] Bauch G, Naguib AF & Seshadri N (1999) MAP equalization of space-time coded signals over frequency selective channels. In: Proc. IEEE Wireless Commun. and Networking Conf., New Orleans, USA, 261–265.
- [318] Yeap BL, Liew TH & Hanzo L (2002) Iterative tree search detection for MIMO wireless systems. In: Proc. IEEE Veh. Technol. Conf., 1689–1693.
- [319] Manton JH & Hua Y (2000) Frequency domain space time coding for MIMO FIR channels. In: Proc. Conf. Asilomar Sign., Syst., Comp., Pacific Grove, USA, 721–724.
- [320] Liu Y, Fitz P & Takeshita OY (2001) Space-time codes performance criteria and design for frequency selective fading channels. In: Proc. IEEE Int. Conf. Commun., Helsinki, Finland.
- [321] Gore D, Sandhu S & Paulraj A (2002) Delay diversity codes for frequency selective channels. In: Proc. IEEE Int. Conf. Commun., New York, USA, 1949–1953.
- [322] Cozzo C & Hughes BL (1999) Joint detection and estimation in space-time coding and modulation. In: Proc. Conf. Asilomar Sign., Syst., Comp., Pacific Grove, USA, vol 1, 613–617.
- [323] Grant A (2000) Joint decoding and channel estimation for space-time codes. In: Proc. IEEE Veh. Technol. Conf., Tokyo, Japan, 416–420.
- [324] Cozzo C & Hughes BL (2000) Joint channel estimation and data symbol detection in space-time communications. In: Proc. IEEE Int. Conf. Commun., New Orleans, USA.
- [325] Baranski Z & Haimovich AM (2002) Iterative channel estimation and sequence detection for space-time coded modulation. In: Proc. Conf. Inform. Sciences Syst. (CISS), Princeton, USA.
- [326] Zhu X & Murch RD (2002) Performance analysis of maximum likelihood detection in a MIMO antenna system. *IEEE Trans Commun* 50(2):187–191.
- [327] Tarokh V, Jafarkhani H & Calderbank AR (1999) Space-time block coding for wireless communications: Performance results. *IEEE J Select Areas Commun* 17(3)(3):451–460.
- [328] Tarokh V, Jafarkhani H & Calderbank AR (1999) Space-time block codes from orthogonal designs. *IEEE Trans Inform Theory* 45(5)(5):1456–1467.
- [329] Agrawal A, Ginis G & Cioffi JM (2002) Channel diagonalization through orthogonal space-time coding. In: Proc. IEEE Int. Conf. Commun., 1621–1624.
- [330] Tirkkonen O & Hottinen A (2002) Square-matrix embeddable space-time block codes for complex signal constellations. *IEEE Trans Inform Theory* 48:384 – 395.
- [331] Alamouti S (1998) A simple transmit diversity technique for wireless communications. *IEEE J Select Areas Commun* 16(8):1451–1458.

- [332] Holma H & Toskal A (2000) WCDMA for UMTS. John Wiley & Sons, New York, 1st edn.
- [333] Alamouti SM, Tarokh V & Poon P (1998) Trellis-coded modulation and transmit diversity: Design criteria and performance evaluation. In: Proc. IEEE Int. Conf. Universal Pers. Commun., Florence, Italy, vol 1, 703–707.
- [334] Bauch G (1999) Concatenation of space-time block codes and turbo TCM. In: Proc. IEEE Int. Conf. Commun., 1202–1206.
- [335] Guey JC (1999) Concatenated coding for transmit diversity systems. In: Proc. IEEE Veh. Technol. Conf., Houston, USA, 2500–2504.
- [336] Yongacoglu A & Siala M (1999) Space-time codes for fading channels. In: Proc. IEEE Veh. Technol. Conf., Houston, USA, 2495–2499.
- [337] Wyk DJV, Oppermann IJ, Pretorius E & Rooyen PGWV (1999) On the construction of layered space-time coded modulation STCM codes employing MTCM code design techniques. In: Proc. IEEE Veh. Technol. Conf., Houston, USA.
- [338] Liew TH, Pliquett J, Yeap BL, Yang LL & L.Hanzo (2000) Comparative study of space-time block codes and various concatenated turbo coding schemes. In: Proc. IEEE Int. Symp. Pers., Indoor, Mobile Radio Commun.
- [339] Kunnari E & Tujkovic D (2001) Performance evaluation of space-time codes in wide-band CDMA over frequency-selective Rayleigh fading downlink channel. In: Proc. IEEE Int. Conf. Commun., Helsinki, Finland.
- [340] Bauch G & Hagenauer J (2001) Analytical evaluation of space-time transmit diversity with FEC-coding. In: Proc. IEEE Global Telecommun. Conf., Texas, USA.
- [341] Borran MJ, Memarzadeh M & Aazhang B (2001) Design of coded modulation schemes for orthogonal transmit diversity. In: Proc. IEEE Int. Symp. Inform. Theory, Washington DC, USA, 339.
- [342] Firmanto W, Yuan J & Vucetic B (1999) Turbo codes with transmit diversity: Performance analysis and evaluation. IEICE Trans Commun E(1):82–87.
- [343] Yuan J, Firmanto W & Vucetic B (2001) Trellis coded 2xMPSK modulation with transmit diversity. KICS J Commun Netw 45(1):273–279.
- [344] Bouzerki H & Miller SL (2001) Analytical tools for space-time codes over quasi-static fading channels. In: Proc. IEEE Global Telecommun. Conf., Texas, USA.
- [345] Bouzerki H & Miller SL (2002) Upper bounds on turbo codes performance over quasi-static fading channels. In: Proc. Conf. Inform. Sciences Syst. (CISS), Princeton, USA.
- [346] Siwamogsatham S & Fitz MP (2002) Improved high-rate space-time codes via concatenation of expanded orthogonal block code and M-TCM. In: Proc. IEEE Int. Conf. Commun., New York, USA, 636–640.
- [347] Siwamogsatham S & Fitz MP (2002) Robust space-time codes for correlated fading channels. IEEE Trans Signal Processing 50(10).
- [348] Tirkkonen O, Boariu A & Hottinen A (2000) Minimal non-orthogonality rate 1 space-time block code for 3+ Tx antennas. In: Proc. IEEE Veh. Technol. Conf., New Jersey, USA, 429–432.

- [349] Jafarkhani H (2001) A quasi-orthogonal space-time block code. *IEEE Trans Commun* 49(1):1–3.
- [350] Tirkkonen O & Hottinen A (2001) Tradeoffs between rate, puncturing and orthogonality in space-time block codes. In: *Proc. IEEE Int. Conf. Commun.*, Helsinki, Finland.
- [351] Choi WJ & Cioffi JM (1999) Space-time block codes over frequency selective Rayleigh fading channels. In: *Proc. IEEE Veh. Technol. Conf.*, vol 5, 2541–2545.
- [352] Lindskog E & Paulraj A (2000) A transmit diversity scheme for channels with intersymbol interference. In: *Proc. IEEE Int. Conf. Commun.*, 307–311.
- [353] Mudulodu S & Paulraj A (2000) A space-time coded transmitter technique for frequency selective fading channel. In: *Proc. IEEE Global Telecommun. Conf.*, 1089–1093.
- [354] Larsson EG, Stoica P, Lindskog E & Li J (2002) Space-time block coding for frequency-selective channels. In: *Proc. IEEE Int. Conf. Acoust., Speech, Signal Processing*, vol 3, 2405–2408.
- [355] Swindlehurst AL & Leus G (2002) Blind and semi-blind equalization for generalized space-time block codes. *IEEE Trans Signal Processing* 50(10).
- [356] Budianu C & Tong L (2002) Channel estimation for space-time orthogonal block codes. *IEEE Trans Signal Processing* 50(10):2515–2528.
- [357] Tarokh V & Lo TKY (1998) Principal ratio combining for fixed wireless application when transmitter diversity is employed. *IEEE Commun Lett* 2(8):223–225.
- [358] Kim YJ, Yoon SY & Lee HS (2000) Generalised suboptimum decoding for space-time codes in qasistatic flat fading channels. *el* 36(2):168–169.
- [359] Huang H, Viswanathan H & Foshini GJ (1999) Achieving high data rates in CDMA systems using BLAST techniques. In: *Proc. IEEE Global Telecommun. Conf.*, Rio de Janeiro, Brazil, 2316–2320.
- [360] Golden GD, Foschini CJ, Valenzuela RA & Wolniansky PW (1999) Detection algorithm and initial laboratory results using V-BLAST space-time communication architecture. *el* 35(1):14–16.
- [361] Hassibi B (2000) An efficient square-root algorithm for BLAST. In: *Proc. IEEE Int. Conf. Acoust., Speech, Signal Processing*, vol 2, 737–740.
- [362] Baro S, Bauch G, Pavlic A & Semmler A (2000) Improving BLAST performance using space-time block codes and turbo decoding. In: *Proc. IEEE Global Telecommun. Conf.*, San Francisco.
- [363] Li X, Huang H, Lozano A & Foshini GJ (2000) Reduced-complexity detection algorithms for systems using multi-element arrays. In: *Proc. IEEE Global Telecommun. Conf.*, San Francisco, USA, 1072–1076.
- [364] Hassell CZW, Thompson JS & annd P. M. Grant BM (2000) A comparison of detection algorithms including BLAST for wireless communication using multiple antennas. In: *Proc. IEEE Int. Symp. Pers., Indoor, Mobile Radio Commun.*, London, UK.
- [365] Farrokhi FR, Lozano A, Foschini GJ & Valenzuela RA (2000) Spectral efficiency of wireless systems with multiple transmit and receive antennas. In: *Proc. IEEE Int. Symp. Pers., Indoor, Mobile Radio Commun.*, London, UK.

- [366] Wuebben D, Boehneke R, Rinas J, Kuehn V & Kammeyer KD (2001) Efficient algorithm for decoding layered space-time codes. *Electron Lett* 37(22):1348–1349.
- [367] Farrokhi FR, Foschini GJ, Lozano A & Valenzuela RA (2001) Link-optimal space-time processing with multiple transmit and receive antennas. *IEEE Commun Lett* 5(3):85–87.
- [368] Lozano A & Papadias C (2002) Layered space-time receivers for frequency-selective wireless channels. *IEEE Trans Commun* 50(1):65–73.
- [369] Biglieri E, Taricco G & Tulino A (2002) Decoding space-time codes with BLAST architectures. *IEEE Trans Signal Processing* 50(10):2547–2552.
- [370] Zanella A, Chiani M, Win MZ & Winters JH (2002) Symbol error probability of high spectral efficiency MIMO systems. In: *Proc. Conf. Inform. Sciences Syst. (CISS)*, Princeton, USA.
- [371] Bjerke BA & Proakis JG (1999) Multiple-antenna diversity techniques for transmission over fading channels. In: *Proc. IEEE Wireless Commun. and Networking Conf.*, New Orleans, USA, vol 3, 1038–1042.
- [372] Biglieri E, Taricco G & Tulino A (2002) Linear receivers for multiple-antenna communication channels: An asymptotic analysis. In: *Proc. IEEE Int. Conf. Commun.*, New York, USA, 1944–1948.
- [373] Nee RV, Zelst AV & Awater G (2000) Maximum likelihood decoding in a space division multiplexing system. In: *Proc. IEEE Veh. Technol. Conf.*, Tokyo, Japan.
- [374] Awater G, Zelst AV & Nee RV (2000) Reduced complexity space division multiplexing receivers. In: *Proc. IEEE Veh. Technol. Conf.*, Tokyo, Japan.
- [375] Li X, Huang H, Foschini GJ & Valenzuela RA (2000) Effects of iterative detection and decoding on the performance of BLAST. In: *Proc. IEEE Global Telecommun. Conf.*, San Francisco, USA, 1061–1066.
- [376] Ariyavisitakul SL (2000) Turbo space-time processing to improve wireless channel capacity. In: *Proc. IEEE Int. Conf. Commun.*, New Orleans, USA, 1238–1242.
- [377] Firmanto W, Yuan J, Lo HL & Vucetic B (2001) Layered space-time coding: Performance analysis and design criteria. In: *Proc. IEEE Global Telecommun. Conf.*, Texas, USA, 1083–1087.
- [378] Lo KL, Marinkovic S, Chen Z & Vucetic B (2002) Performance comparison of layered space time codes. In: *Proc. IEEE Int. Conf. Commun.*, New York, USA, 1382–1387.
- [379] Shiu D & Kahn JM (1999) Layered space-time codes for wireless communications using multiple transmit antennas. In: *Proc. IEEE Int. Conf. Commun.*, 436–440.
- [380] Matache A, Wesel RD & Shi J (2002) Trellis coding for diagonally layered space-time systems. In: *Proc. IEEE Int. Conf. Commun.*, New York, USA, 1388–1392.
- [381] Raheli R, Polydoros A & Tzou CK (1995) Per-survivor processing: A general approach to MLSE in uncertain environments. *IEEE Trans Commun* 43(2):354–364.
- [382] Caire G (2000) PSP-based space-time schemes for large spectral efficiency. In: *Proc. Conf. Inform. Sciences Syst. (CISS)*, Princeton, USA.
- [383] Berther AO, Visoz R & Unal S (2001) Iterative decoding of serially concatenated multilayered trellis-coded modulations in the presence of intersymbol interference and noise. In: *Proc. IEEE Global Telecommun. Conf.*, Texas, USA, 1042–1047.

- [384] Choi WJ, Negi R & Cioffi JM (2000) Combined ML and DFE decoding for the V-BLAST system. In: Proc. IEEE Int. Conf. Commun., New Orleans, USA, 1243–1248.
- [385] Shiu D (2000) Iterative decoding for layered space-time codes. In: Proc. IEEE Int. Conf. Commun., New Orleans, USA.
- [386] Abe T & Matsumoto T (2001) Space-time turbo equalization and symbol detection in frequency selective MIMO channels. In: Proc. IEEE Veh. Technol. Conf., Rhodes, Greece, 1230–1234.
- [387] Sellathurai M & Haykin S (2002) TURBO-BLAST for wireless communications: Theory and experiments. IEEE Trans Signal Processing 50(10):2538–2546.
- [388] Tarokh V, Naguib A, Seshadri N & Calderbank AR (1999) Combined array processing and space-time coding. IEEE Trans Inform Theory 45(4):1121–1128.
- [389] Su HJ & Geraniotis E (2000) Maximum signal-to-noise ratio array processing for space-time coded system. In: Proc. IEEE Int. Symp. Pers., Indoor, Mobile Radio Commun., London, UK.
- [390] Tao M & Cheng RSK (2001) Low complexity post-ordered iterative decoding for generalized layered space-time coding systems. In: Proc. IEEE Int. Conf. Commun., Helsinki, Finland.
- [391] Jason LHC, Tao M & Cheng RS (2001) Optimal power allocation scheme on generalized layered space-time coding systems. In: Proc. IEEE Int. Conf. Commun., Helsinki, Finland.
- [392] Jason LHC & Cheng RS (2000) Low complexity turbo space-time code for system with large number of antennas. In: Proc. IEEE Global Telecommun. Conf., San Francisco.
- [393] Hassibi B & Hochwald BM (1999) High-rate codes that are linear in space and time. IEEE Trans Inform Theory submitted .
- [394] Heath RW, Bolcskei H & Paulraj AJ (2001) Space-time signaling and frame theory. In: Proc. IEEE Int. Conf. Acoust., Speech, Signal Processing, Salt Lake City, USA, 2445–2448.
- [395] Medles A & Slock DTM (2002) Multistream space-time coding by spatial spreading, scrambling and delay diversity. In: Proc. IEEE Int. Conf. Acoust., Speech, Signal Processing, vol 3, 2429–2432.
- [396] Heath RW & Paulraj A (2002) Linear dispersion codes for MIMO systems based on frame theory. IEEE Trans Signal Processing 50(10).
- [397] Sidiropoulos ND & Budampati RS (2002) Khatri-Rao space-time codes. IEEE Trans Signal Processing 50(10).
- [398] Ariyavisitakul SL (2000) Turbo space-time processing to improve wireless channel capacity. IEEE Trans Commun submitted .
- [399] McCormick AC & Thompson GJS (2002) Walsh coding across multiple antennas for high data rate wireless services. In: Proc. IEEE Int. Conf. Acoust., Speech, Signal Processing, vol 3, 2449–2452.
- [400] Gamal HE & Hammons AR (2001) A new approach to layered space-time coding and signal processing. IEEE Trans Inform Theory 47(6):2321–2334.

- [401] Caire G & Colavolpe G (2001) On space-time coding for quasi-static multiple-antenna channels. In: Proc. IEEE Global Telecommun. Conf., Texas, USA, 1078–1082.
- [402] Lu B & Wang X (2000) Space-time code design in OFDM systems. In: Proc. IEEE Global Telecommun. Conf., San Francisco, USA.
- [403] Narayanan KR (1999) Turbo decoding of concatenated space-time codes. In: Proc. Annual Allerton Conf. Commun., Control, Computing.
- [404] Cui D & Haimovich AM (2000) Design and performance of turbo space-time coded modulation. In: Proc. IEEE Global Telecommun. Conf.
- [405] Firmanto W, Chen Z, Vucetic B & Yuan J (2001) Design of space-time turbo trellis coded modulation for fading channels. In: Proc. IEEE Global Telecommun. Conf.
- [406] Stefanov A & Duman T (1999) Turbo coded modulation for wireless communications with antenna diversity. In: Proc. IEEE Veh. Technol. Conf., 1565–1569.
- [407] Liu Y, Fitz MP & Takeshita OY (2000) QPSK space-time turbo codes. In: Proc. IEEE Int. Conf. Commun., 292–296.
- [408] Su HJ & Geraniotis E (2001) Space-time turbo codes with full antenna diversity. IEEE Trans Commun 49(1):47–57.
- [409] Lin X & Blum RS (2000) Improved space-time codes using serial concatenation. IEEE Commun Lett 4(7):221–223.
- [410] Cui D & Haimovich AM (2001) Error performance analysis of turbo space-time coded modulation over fading channels. In: Proc. IEEE Int. Conf. Commun.
- [411] Cui D & Haimovich AM (2001) Error performance analysis of multilevel turbo-code with antenna diversity. In: Proc. IEEE Veh. Technol. Conf., 1299–1303.
- [412] Cui D & Haimovich AM (2001) Performance of parallel concatenated space-time codes. IEEE Commun Lett 5(6):236–238.
- [413] Firmanto W, Chen Z & Yuan BVJ (2002) Space-time turbo trellis coded modulation for wireless data communications. EURASIP Journal on Applied Signal Processing Special Issue on Space Time Coding and its Applications Part II 2002(5):459–470.
- [414] Stefanov A & Duman T (1999) Turbo coded modulation for systems with transmit and receive antenna diversity. In: Proc. IEEE Global Telecommun. Conf., 2336–2340.
- [415] Stefanov A & Duman T (2001) Turbo-coded modulation for systems with transmit and receive antenna diversity over block fading channels: System model, decoding approaches, and practical considerations. IEEE J Select Areas Commun 19(5):958–968.
- [416] Stefanov A, AlRustamani AA & Vojcic B (2001) Turbo-greedy coding for high data rate wireless communications: Principles and robustness. In: Proc. IEEE Veh. Technol. Conf., 1272–1276.
- [417] Amis KC & Pyndiah R (2000) Block turbo codes for transmit and receive diversity systems. In: Proc. Int. Symp. Turbo Cod. Related Topics, Brest, France, 379–382.
- [418] Yamashita M, Ohgane T & Ogawa Y (2001) Transmit diversity technique using space division multiplexing and turbo codes. Electron Lett 37(3):184–185.

- [419] Liu Y, Fitz MP, Takeshita OY & Han Z (2000) A rank criterion for QAM space-time codes with application to turbo coding. In: Proc. Int. Workshop Sensor, Array, Multichannel Sign. Process., 193–197.
- [420] Liu Y, Fitz MP & Takeshita OY (2001) Full rate space-time turbo codes. *IEEE J Select Areas Commun* 19(5):969–980.
- [421] Wishwanath S, Yu W, Negi R & Goldsmith A (2000) Space-time turbo codes: Decorrelation properties and performance analysis for fading channels. In: Proc. IEEE Global Telecommun. Conf.
- [422] Hiroike A, Adachi F & Nakajima N (1992) Combined effects of phase sweeping transmitter diversity and channel coding. *IEEE Trans Veh Technol* 41(2):170–176.
- [423] Shi W, Kominakis C, Wessel RD & Daneshrad B (2001) Robustness of space-time turbo codes. In: Proc. IEEE Int. Conf. Commun.
- [424] Huang E, Gatherer A, Muharemovic T & Hocevar D (2001) Improving performance of a space-time turbo code in a Rayleigh fading channel. In: Proc. IEEE Veh. Technol. Conf., 3–7.
- [425] Lin X & Blum RS (2002) Analysis of space-time codes using serial concatenation structure. *IEEE Trans Commun* submitted .
- [426] Chi Z, Wang Z & Parhi KK (2000) Iterative decoding of space-time trellis codes and related implementation issues. In: Proc. Conf. Asilomar Sign., Syst., Comp.
- [427] Kim WG, Ku BJ, Back LH, Yang IY & Kang CE (2000) Serially concatenated space-time code (SCSTC) for high rate wireless communication systems. *Electron Lett* 36(7):646–648.
- [428] Li S & Han C (2001) A flexible space-time turbo coding scheme. In: Proc. Int. Conf. Info-Tech & Info-Net.
- [429] Reial A & Wilson SG (2000) Concatenated space-time coding. In: Proc. Conf. Asilomar Sign., Syst., Comp.
- [430] Yim EJ, Kim DK & Song HY (2002) MIMO iterative decoding of serial concatenation using space-time trellis codes. *Electron Lett* 38(4):190–191.
- [431] Lin X & Blum RS (2001) Guidelines for serially concatenated space-time code design in flat Rayleigh fading channels. In: Proc. IEEE Workshop Sign. Process. Advances Wireless Commun., Taoyuan, Taiwan, 247–250.
- [432] Stefanov A & Duman T (2002) Performance bounds for turbo coded multiple antenna systems. In: Proc. IEEE Int. Symp. Inform. Theory, Lousanne, Switzerland, 302.
- [433] Nee RV, Awater G, Morikura M, Takanashi T, Webster M & Halford K (1999) High-rate wireless LAN standards. *IEEE Commun Mag* 37(12).
- [434] Cimini Jr. LJ (1985) Analysis and simulation of a digital mobile channel using orthogonal frequency division multiplexing. *IEEE Trans Commun* 33(7):665–675.
- [435] Cimini Jr. LJ, Daneshrad B & Sollenberger NR (1996) Clustered OFDM with transmitter diversity and coding. In: Proc. IEEE Global Telecommun. Conf., London, UK, vol 3, 703–707.
- [436] Kim J, Cimini Jr. LJ & Chuang JC (1998) Coding strategies for ofdm with antenna diversity high-bit-rate mobile data applications. In: Proc. IEEE Veh. Technol. Conf., vol 2, 763–767.

- [437] Lin L, Cimini Jr. LJ & Chuang JCI (2000) Comparison of convolutional and turbo codes for OFDM with antenna diversity in high-bit-rate wireless applications. *IEEE Commun Lett* 4(9):277–279.
- [438] Li Y, Chuang JC & Sollenberger NR (1999) Transmitter diversity for OFDM systems and its impact on high-rate data wireless networks. *IEEE J Select Areas Commun* 17(7):1233–1243.
- [439] Sayeed Z & Weerackody V (1999) Transmit diversity for coded OFDM systems in single frequency networks. In: *Proc. IEEE Global Telecommun. Conf.*
- [440] Kaiser S (2000) Spatial transmit diversity techniques for broadband OFDM systems. In: *Proc. IEEE Global Telecommun. Conf.*
- [441] Dammann A & Kaiser S (2001) Standard conformable antenna diversity techniques for OFDM and its application to the DVB-T system. In: *Proc. IEEE Global Telecommun. Conf.*
- [442] Lee KF & Williams DB (2000) A space-time coded transmitter technique for frequency selective fading channel. In: *Proc. Int. Workshop Sensor, Array, Multichannel Sign. Process.*, 149–152.
- [443] Mudulodu S & Paulraj A (2000) A transmit diversity scheme for frequency selective fading channels. In: *Proc. IEEE Global Telecommun. Conf.*, San Francisco, USA.
- [444] Bolcskei H & Paulraj AJ (2000) Space-frequency coded broadband OFDM systems. In: *Proc. IEEE Wireless Commun. and Networking Conf.*, 1–5.
- [445] Liu Z, Giannakis GB, Barbarossa S & Scaglione A (2001) Transmit antenna space-time block coding generalized OFDM in the presence of unknown multipath. *IEEE J Select Areas Commun* 19:1352–1364.
- [446] Liew TH, Choi BJ & Hanzo L (2001) Comparative study of concatenated turbo coded and space-time block coded as well as space-time trellis coded OFDM. In: *Proc. IEEE Veh. Technol. Conf.*, vol 2, 781–785.
- [447] Galacher RAS & Wang Z (2001) Improving performance of coherent coded OFDM systems using space time transmit diversity. *Electron Lett* 37(7):457–458.
- [448] Lu B, Wang X & Li YG (2002) Iterative receivers for space-time block coded OFDM systems in dispersive fading channels. *IEEE Wirel Commun* 1(2):213–225.
- [449] Agrawal D, Tarokh V, Naguib A & Seshadri N (1998) Space-time coded OFDM for high data-rate wireless communication over wideband channels. In: *Proc. IEEE Veh. Technol. Conf.*, vol 3, 2232–2236.
- [450] Bolcskei H & Paulraj AJ (2001) Space-frequency coded broadband OFDM systems. In: *Proc. IEEE Int. Symp. Inform. Theory*, Washington DC, USA, 1–5.
- [451] Bolcskei H & Paulraj AJ (2000) MIMO-OFDM for future broadband wireless access. In: *Proc. IEEE Veh. Technol. Conf.*, tutorial, vol 1, 687–693.
- [452] Lu B, Wang X & Narayanan KR (2002) LDPC-based space-time coded OFDM systems over correlated fading channels: Performance analysis and receiver design. *IEEE Trans Commun* 50(1):74–88.
- [453] Leveil SR & Gosse K (2002) Space-time coding options for OFDM based WLANs. In: *Proc. IEEE Veh. Technol. Conf.*, 904–908.

- [454] Canagarajah N, Fletcher P, McGeehan J, Nix A & Piechocki R (2001) Performance of space-time coding with Hiperlan/2 and IEEE 802.11a WLAN standards on real channels. In: Proc. IEEE Veh. Technol. Conf., vol 2, 848–852.
- [455] Liu Z, Xin Y & Giannakis GB (2002) Space-time frequency trellis coding for frequency-selective fading channels. In: Proc. IEEE Veh. Technol. Conf., 145–149.
- [456] Boubaker N, Letaief KB & Murch RD (2001) A layered space-time coded wideband OFDM architecture for dispersive wireless links. In: Proc. IEEE Symp. Comp. & Commun., 518–523.
- [457] Giangaspero L, Paltenghi G & Agarossi L (2001) A MIMO architecture for wireless indoor applications. In: Proc. IEEE Int. Conf. Wireless LANs & Home Network., Singapore, 317–326.
- [458] Li Y, Winters JH & Sollenberger NR (2001) Signal detection for MIMO-OFDM wireless communications. In: Proc. IEEE Int. Conf. Commun.
- [459] Blum RS, Yan Q, Li Y & Winters J (2001) Improved techniques for 4 transmit 4 receive antenna MIMO-OFDM for wireless communications. In: Proc. IEEE Veh. Technol. Conf., 1298–1302.
- [460] Blum RS, Li Y, Winters J & Yan Q (2001) Improved space-time coding for MIMO-OFDM for wireless communications. IEEE Trans Commun 49(11):1873–1878.
- [461] Zexian L, Vehkopera M, Tujkovic D, Latva-aho M & Juntti M (2002) Performance evaluation of space-frequency coded MIMO MC-CDMA system. In: Proc. IST Mobile Summit, Aveiro, Portugal, to appear.
- [462] Ng BK & Sousa E (2000) Multiple antennas and multiuser detection in high data rate CDMA systems. In: Proc. IEEE Veh. Technol. Conf., vol 1, 556–560.
- [463] Thompson JS, Grant PM & Mulgrew B (1999) Downlink transmit diversity schemes for CDMA networks. In: Proc. IEEE Veh. Technol. Conf., 1382–1386.
- [464] Papadias C (1999) On the spectral efficiency of space-time spreading schemes for multiple antenna CDMA systems. In: Proc. Conf. Asilomar Sign., Syst., Comp., vol 1, 639–643.
- [465] Hottinen A, Raitola M & Wichman R (1999) Transmission diversity in wideband CDMA. In: Proc. IEEE Veh. Technol. Conf., vol 2, 1545–1549.
- [466] Buchrer RM, Jiann T & Soni RA (1999) Open-loop transmit diversity in IS-2000 systems. In: Proc. Conf. Asilomar Sign., Syst., Comp., vol 1, 654–658.
- [467] Ko YC, Alouini MS & Simon MK (1999) Performance analysis and optimization of switched diversity systems. In: Proc. IEEE Veh. Technol. Conf., 1366–1371.
- [468] Correia A, Hottinen A & Wichman R (2000) Space-time transmitter diversity schemes for wideband CDMA. In: Proc. IEEE Veh. Technol. Conf., vol 1, 313–317.
- [469] Gray SD & Rajan D (1999) Transmit diversity schemes for CDMA-2000. In: Proc. IEEE Wireless Commun. and Networking Conf., vol 2, 669–673.
- [470] Bjerke BA, Proakis JG & Zvonar Z (2000) Antenna diversity combining schemes for WCDMA systems in fading multipath channels. In: Proc. IEEE Veh. Technol. Conf., 421–428.

- [471] Goransson B, Hedlund L, Karlsson M, Parkvall S & Samuelsson M (2000) Transmit diversity in WCDMA: Link and system level results. In: Proc. IEEE Veh. Technol. Conf., vol 2, 864–868.
- [472] Ng BK & Sousa E (2000) Space-time spreading multilayered CDMA system. In: Proc. IEEE Global Telecommun. Conf., vol 3, 1854–1858.
- [473] Cioffi J, Negi R & Tehrani AM (1999) Space-time coding over a code division multiple access system. In: Proc. IEEE Wireless Commun. and Networking Conf., vol 1, 134–138.
- [474] Wyk DV, Oppermann IJ & Linde LP (1999) Low rate coding considerations for space-time coded DS/CDMA. In: Proc. IEEE Veh. Technol. Conf., 2520–2524.
- [475] Gaspa R & Fonollosa JR (2000) Turbo trellis coded modulation for fading channels. In: Proc. IEEE Veh. Technol. Conf.
- [476] Yang H, Yuan J & Vucetic B (2002) Performance of space-time trellis codes in frequency selective WCDMA systems. In: Proc. IEEE Veh. Technol. Conf., 233–237.
- [477] Tessi R, Tujkovic D, Mucchi L & Kunnari E (2001) Space-time coded satellite diversity in S-UMTS. In: Eur. Space Agen. Int. Workshop on Dig. Sign. Process. Techn. Space Commun.
- [478] Ban K, Katayama M, Stark WE, Yamazato T & Ogawa A (1997) Convolutionally coded DS/CDMA system using multi-antenna transmission. In: Proc. IEEE Global Telecommun. Conf., Phoenix, USA, vol 1, 92–96.
- [479] Wyk DV & Linde LP (1998) Turbo-coded/multi-antenna diversity combining scheme for DS/CDMA systems. In: Proc. IEEE Int. Symp. Spread Spectrum Techniques and Applications, 18–22.
- [480] Wyk DV & Oppermann IJ (1999) Performance tradeoff among spreading, coding and multiple-antenna transmit diversity for high capacity space-time coded DS/CDMA. In: Proc. IEEE Military Commun. Conf.
- [481] Oppermann IJ (1999) CDMA space-time coding using an LMMSE receiver. In: Proc. IEEE Int. Conf. Commun., 182–187.
- [482] Kunnari E & Tujkovic D (2001) Convolutionally coded multi-antenna transmission in WCDMA over frequency-selective Rayleigh fading channel. In: Proc. IEEE Veh. Technol. Conf.
- [483] Wyk DV & Rooyen PV (2000) On the performance of super-orthogonal turbo-transmit diversity for CDMA cellular communication. In: Proc. IEEE Int. Symp. Spread Spectrum Techniques and Applications, New Jersey, USA, 127–131.
- [484] Rajan D, Erkip E & Aazhang B (1999) New spread spectrum techniques for multiple antenna transmit diversity. In: Proc. IEEE Global Telecommun. Conf.
- [485] Burr A (2000) Evaluation of space-time turbo codes for third generation systems. In: Proc. IEEE Veh. Technol. Conf., 714–718.
- [486] Caire G & Viterbo E (1998) Upper bound on the frame error probability of terminated trellis codes. *IEEE Commun Lett* 2(1):2–4.
- [487] Malkamaki E & Leib H (1999) Evaluating the performance of convolutional codes over block fading channels. *IEEE Trans Inform Theory* 45(5):1643–1646.

- [488] Divsalar D, Dolinar S & Polara F (2001) Iterative turbo decoder analysis based on density evolution. *IEEE J Select Areas Commun* 19(5):891–907.
- [489] Tuchler M, ten Brink S & Hagenauer J (2002) Measures of tracing convergence of iterative decoding algorithms. In: *Proc. Conf. ITG TUM Munich*.
- [490] Gamal HE & Hammons AR (2001) Analyzing the turbo decoder using Gaussian approximation. *IEEE Trans Commun* 47(2):2321–2334.
- [491] Jung YS & Lee JH (2001) New measure of coding gain for space-time trellis codes. In: *Proc. IEEE Int. Symp. Inform. Theory, Washington DC, USA*, 198.
- [492] Sasazaki Y & Ohtsuki T (2002) Improved design criteria and new trellis codes on space-time trellis coded modulation in fast fading channels. In: *Proc. IEEE Global Telecommun. Conf.*

List of symbols and abbreviations

N	number of transmit antennas
M	number of receive antennas
n	integer index
m	integer index
i	integer index
P_T	average total transmitted power
\mathbf{I}_M	an $M \times M$ identity matrix
α_{mn}	fading gain from transmit antenna n to receive antenna m
\mathbf{P}	covariance matrix of N transmitted signals
P_n	n th eigenvalue of the covariance matrix \mathbf{P}
\mathbf{H}	$M \times N$ channel matrix with α_{mn} in its (m, n) entry
$\lambda_{\mathbf{H},n}$	n th eigenvalue of $\mathbf{H}\mathbf{H}^H$
\mathbf{V}	unitary $N \times N$ matrix
\mathbf{U}	unitary $M \times M$ matrix
B	number of independent fading blocks per frame
T	coherence time of channel in symbols
L_M	number of resolvable multipath components
L	length of transmission frame in symbols
$c_n(l)$	signal associated to transmit antenna n in time instant l
$e_n(l)$	erroneously detected version of the transmitted signal $c_n(l)$
$\Delta_n^{ec}(l)$	arithmetical difference between $c_n(l)$ and $e_n(l)$
$r_m(l)$	received signal at antenna m at time instant l
$\eta_m(l)$	AWGN samples at antenna m in time instant l
\mathbf{D}_c	$L \times NL$ block matrix of N $L \times L$ matrices $\mathbf{D}_c(n)$
$\mathbf{D}_c(n)$	$L \times L$ diagonal matrix with $c_n(l)$ in its l th diagonal entry
\mathbf{D}_e	same as \mathbf{D}_c but for erroneously detected sequence $e_n(l)$
$\mathbf{D}_e(n)$	same as $\mathbf{D}_c(n)$ but for erroneously detected sequence $e_n(l)$

D_{ec}	codeword difference matrix
$C_{s,1}$	signal matrix of a MISO channel
$C_{s,1awgn}$	signal matrix of a MISO AWGN channel
$C_{s,1slow}$	signal matrix of a MISO slow fading channel
$\tilde{C}_{s,1slow}$	eigenvalue equivalent matrix of $C_{s,1slow}$
$C_{s,1fast}$	signal matrix of a MISO fast fading channel
C_{α_1}	covariance matrix of a MISO channel
$\Delta_H(C_{s,1})$	rank of the signal matrix $C_{s,1}$
$\lambda_i(C_{s,1})$	i th non-zero eigenvalue of the signal matrix $C_{s,1}$
$\Delta_P(C_{s,1})$	geometric mean of the non-zero eigenvalues of the signal matrix $C_{s,1}$
r	ML dimensional vector, received signals
η	ML dimensional vector of AWGN samples
α	MNL dimensional vector of fading taps
$D_{c,M}$	$L \times MNL$ block matrix of M $L \times NL$ matrices D_c
$D_{e,M}$	same as $D_{c,M}$ but for erroneously detected sequence $e_n(l)$
$C_{s,M}$	signal matrix of a MIMO channel
$H(\Delta_H, \Delta_P)$	average number of error events with given Δ_H and Δ_P
$P(\Delta_H, \Delta_P)$	pair-wise error probability for the error event with given Δ_H and Δ_P
K	number of information bits per trellis transition
Z	logarithm 2 of the modulation level
k	integer index
z	integer index
l	integer index
\mathbf{x}	LK dimensional vector, input information bits in one frame
$\mathbf{x}(l)$	K dimensional vector, input information bits in time instant l
\mathbf{c}^1	LN dimensional vector, coded frame of the first constituent code
\mathbf{c}^2	LN dimensional vector, coded frame of the second constituent code
$\mathcal{I}(l)$	union set operation defined over integers l
\mathcal{I}_O	subset of integers
\mathcal{I}_E	subset of integers
$\pi(i)$	position of the i th input bit after the information interleaver mapping
π_O	length $LK/2$ odd symbol positioned bit-wise information interleaver
π_E	length $LK/2$ even-symbol positioned bit-wise information interleaver
π_c	symbol-wise channel interleaver
Δ_{DS}	spectral product
D	set of all distinct pairs $\langle \Delta_H, \Delta_P \rangle$ in the spectrum of the code

\mathcal{P}	significant part of the code's distance spectrum
ν_k	memory order of the k th shift register
ν	memory order of the constituent code
$\mathbf{y}_n(l)$	Z dimensional vector, coded bits prior to modulation at transmit antenna n in time instant l
$y_n^z(l)$	the z th bit in $\mathbf{y}_n(l)$
$y_n^z(D)$	binary polynomial representation of $y_n^z(l)$
f_{nzk}^x	binary constant
b_{ku}^x	binary constant
$f_{nzk}(D)$	degree ν_k binary feed-forward polynomial from shift register k to the output bit z at transmit antenna n
$b_{ku}(D)$	degree $\nu_u - 1$ binary feed-backward polynomial from shift register u to the input of the shift register k
B	set of feed-backward polynomials for the given constituent code
F	set of feed-forward polynomials for the given constituent code
AOA	angle of arrival
AOD	angle of departure
AWGN	additive white Gaussian noise
BICM	bit-interleaved coded modulation
BLAST	Bell-labs space-time
BS	base station
CC	constituent code
CCI	co-channel interference
CDMA	code division multiple access
CSI	channel state information
DD	delay diversity
DS	distance spectrum
EQPA	equal power allocation
FDD	frequency division duplex
FER	frame error probability
GA	general algorithm
GU	geometrically uniform
GNU	geometrically non-uniform
GSM	Global system for mobile communications
i.i.d.	independent identically distributed
ISI	inter symbol interference
LLR	log-likelihood ratio
LST	layered space-time
OFDM	orthogonal frequency division multiplexing
MAI	multiple access interference

MAP	maximum <i>a posteriori</i>
MC	multi carrier
MIMO	multiple-input multiple-output
MISO	multiple-input single-output
MLD	maximum likelihood decoding
MS	mobile station
PEP	pair-wise error probability
PSK	phase shift keying
Rec-STTrC	recursive space-time trellis code
SC	single carrier
SINR	signal to interference plus noise ratio
SNR	signal to noise ratio
SIMO	single-input multiple-output
SISO	single-input single-output
SfISfO	soft-input soft-output
SOVA	soft output Viterbi algorithm
ST	space-time
STC	space-time code
STTuCM	space-time turbo coded modulation
STTrC	space-time trellis code
Tarokh-STTrC	Tarokh et al. space-time trellis code [254]
TDD	time division duplex
TDMA	time division multiple access
TrCM	trellis coded modulation
TuC	turbo code
TuCM	turbo coded modulation
UB	union bound
QAM	quadrature amplitude modulation
WCDMA	wide-band code division multiple access
WFPA	water filling power allocation
WLAN	wireless local area network

Errata

Location:	Now is:	Should be:
Paper IX		
p. 2, eq. 2	$\frac{Es}{2N_0}$	$\frac{SNR}{N}$
p. 3, col. 1	For the given pair-wise error event ...	For $Z = 2$ and given pair-wise error event ...
p. 4, eq. 9	$H_{1,O}^{h_{O1}, h_{O2}, h_{E1}, h_{E2}}$ $H_{2,O}^{h_{E1}, h_{E2}, h_{O1}, h_{O2}}$	$H_{1,O}^{h_{E1}, h_{E2}, h_{O1}, h_{O2}}$ $H_{2,O}^{h_{O1}, h_{O2}, h_{E1}, h_{E2}}$
p. 4, eq. 10	$\left(\frac{L}{2Z} - \lceil \frac{l_{tot}}{2} \rceil + k \right)$	$\left(\frac{L}{2} - \lceil \frac{l_{tot}}{2} \rceil + k \right)$
Paper X		
p. 80, eq. 2	$\frac{Es}{2N_0}$	$\frac{SNR}{N}$
p. 81, col. 1	For the given pair-wise error event ...	For $Z = 2$ and given pair-wise error event ...
p. 83, eq. 12	$2^k \left(\frac{L}{2Z} - \lceil \frac{l_{tot}}{2} \rceil + k \right)$	$\left(\frac{L}{2} - \lceil \frac{l_{tot}}{2} \rceil + k \right)$.
	where factor 2^k denotes the number of variations of length k for the set of two elements $\{odd, even\}$.	Factor K enumerates any combination of odd- and even-punctured single error events.
Paper XI		
Tab. 1	10.7×10^{-2}	2.5×10^{-3}