

Double-sided environmental sensor for high-efficiency particulate air filter

Pauliina Vilmi
*Optoelectronics and Measurement
Techniques unit
University of Oulu
Oulu, Finland
pauliina.vilmi@oulu.fi*

Rafal Sliz
*Optoelectronics and Measurement
Techniques unit
University of Oulu
Oulu, Finland
rafal.sliz@oulu.fi*

Tapio Fabritius
*Optoelectronics and Measurement
Techniques unit
University of Oulu
Oulu, Finland
tapio.fabritius@oulu.fi*

Abstract—A capacitive environmental sensor pair is fabricated on a High-Efficient Particulate Air (HEPA) filter. The sensors are fabricated on both sides of the filter. The front side sensor is exposed to the conditions of the dirty side of a filter while the other is used as a reference on the back side. The capacitances on both sensors are measured to analyze particulate accumulation on the filter. It is observed that the capacitance of the front side sensor changes significantly, when the filter becomes dirty, whilst the reference capacitance has a minor change. The capacitance difference between the sensors was up to 45 %. After cleaning the filter, the capacitance values returned to the initial level on both sides. The proposed sensor concept is capable for a quantitative online monitoring of air filter condition, enabling interesting possibilities in IoT based automation systems.

Keywords—capacitive sensor, HEPA, printed electronics

I. INTRODUCTION

HEPA filters are designed to purify air at very efficient rate. They are used at clean room facilities, in vacuum cleaners, breathing masks, etc. [1-3] Basically everywhere, where air needs to be cleaned. To be called HEPA, they must filter at least 99.95 % (European Standard) [4] or 99.97 % (ASME) [5] of all particles. The European Standard defines classes for HEPA filters according to their efficiency at most penetrable particle size (0.21 μm) up to 99.999995 % (HEPA class U17). There are also filters which are fabricated similarly, but do not fulfill the mentioned specification. They are usually called HEPA-type filters and are fully suitable for many applications with less critical requirements. HEPA is usually folded to a zigzag shape to get as much filtering surface area as possible. As the surface area is larger, the filter is functional for longer time. There is usually also a pre-filter placed in front of HEPA, which traps the larger particles, hair, dust, etc. and extends the time of use for the HEPA filter.

HEPA filters function differently than filters defined by their pore size, the holes between the fibers do not need to be smaller than the particles they filter. The filter is formed of randomly arranged fibers, which can be made of fiberglass or various polymers for example, with a diameter starting from smaller than 1 μm [6]. The main filtration mechanisms with the approximate particle size they are effective for, are inertial impaction (above 1 μm), diffusion (below 0.5 μm), interception (0.5 μm to 1 μm), sieving (filter opening is smaller than the particle) and electrostatic charge (0.01 μm to

2 μm) [7, 8]. The most penetrable particle size is 0.21 μm , which is covered mainly by the diffusion of the mentioned filtration mechanisms.

A need for intelligent sensors is constantly growing. For instance, IoT applications rely on sensors of various functionalities, to achieve all the required information from the surrounding environment. IoT connects devices in industry through the Internet for more efficient performance. As air filters are used in a wide range of devices, IoT can make them also more efficient. IoT is also infiltrating into peoples' everyday life and the main reason is to make the life more comfortable. This is also the purpose of our presented concept.

The dirtiness level of the HEPA filter has an influence on the filter and the whole automation system performance decreasing the air quality and energy efficiency. Due to the lack of quantitative data about filter conditions, their replacement cycles are unoptimized increasing the maintenance costs. The filter conditions can be estimated indirectly by measuring pressure drops in the system or monitoring the power consumption of the air supply unit. Those methods are not specific for the filter conditions making them unpractical. That is why sensor systems embedded directly into filters are needed. In this study, we propose a simple printed electronic sensor concept for filter condition monitoring.

Silk screen printing [9, 10] is one of the oldest and most common fabrication methods for printed electronics [11-13], and its' basic concept dates back to hundreds of years. It has a vast range of possibilities in electronics fabrication due to its simple and versatile operating principle. It uses a patterned stencil, through which a paste is pressed with a squeegee. Single layers of various thicknesses can be made. The thickness is adjusted by the thickness of the emulsion, which defines the pattern on the stencil. By repeating different patterns, multilayer structures are easy to make. In addition, screen printing is also roll-to-roll compatible [14, 15]. By changing the wire diameter and the mesh count (number of wires per inch), the stencil can be custom-made to be compatible with the used paste and the desired pattern resolution. Because of the high viscosity paste, screen printing allows the use of coarse substrates as HEPA. Screen printing has been used to fabricate environmental sensors also previously [16, 17], but those sensors were printed only on one side of the substrate and they were not dedicated for filtering applications.

The last author of this paper is partially supported by Academy of Finland's FIRI funding (grant no. 320017).

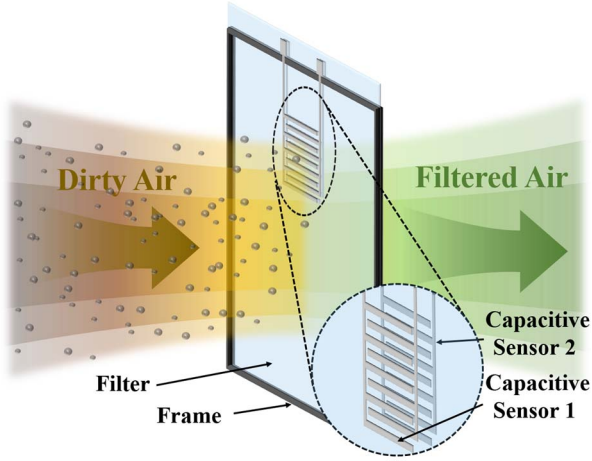

Fig. 1. A schematic presentation of a filter, with sensors added to the surface for detection of the purity level of the filter. The sensor on the dirty air side will change its capacitance when dirt accumulates onto it, while the reference sensor on the filtered air side will keep the same initial value.

II. PRINCIPLE OF THE PROPOSED SENSOR CONCEPT

The sensors printed on the HEPA surface are finger capacitors, which change their capacitance according to the environment (the change of permittivity) being thus sensitive to humidity change and the presence of physical particles.

When HEPA filters particles from the passing air, they accumulate to (mainly) one side of the filter. When two identical sensors are placed on both sides of the filter in question, the conditions around one sensor change more than the other, and this changes the capacitance of the sensor in question. By measuring the capacitances on both sides, the difference can be distinguished. The idea of the concept is presented in Fig. 1.

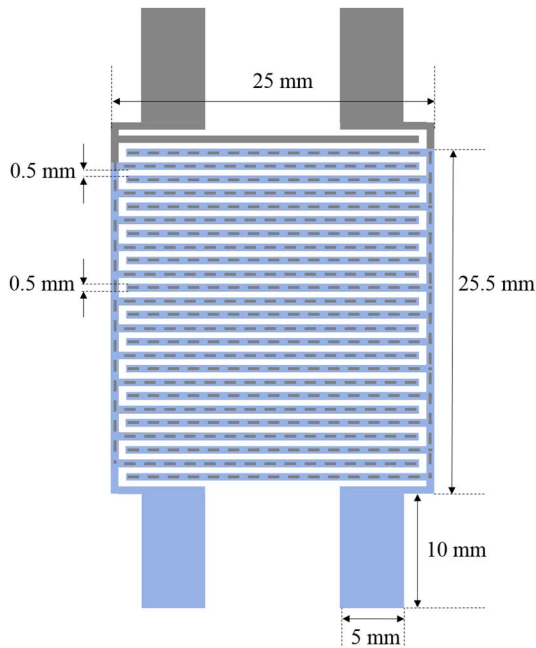

Fig. 2. The alignment of the printed sensors with sensor dimensions. The blue color presents the front side of the sensor and the gray color presents the back side of the sensor. The dashed gray areas are aligned with the front side.

If a sensor is placed only on the one side of the filter, temperature and humidity must be constant throughout the measurement process, because the sensor element reacts also to them. In our concept, the reference sensor on the back side of the filter can be assumed to react equally to the change of temperature and humidity, thus improving the selectivity of the sensor.

III. MATERIALS AND METHODS

A. Used materials and sensor fabrication

A flat HEPA filter (AX6700HS from Lydall Performance Materials), with HEPA class of U15 (efficiency of 99.9995 %), is used in this work. Capacitive finger structure is silkscreen printed on both sides of the filter with a silver paste (LS-411AW from Asahi). Without further optimization, a simple capacitive interdigitated layout was used for demonstrating the performance of the proposed concept (See Fig. 2)

The same pattern is printed on both sides, so that all the overlapping parts of the sensors are manually aligned. The contacts are placed on the opposite sides, to ease the measurement probe attachment during the characterization stage.

The pattern is screen printed on the front side of the filter and the sample is placed in an oven at 150 °C for 20 minutes for curing. Then, the same pattern is printed on the back side of the filter on top of a light table to help with the alignment. Consequently, the sample is placed in the oven at 150 °C for 20 minutes. The specifications of the used stencil were: mesh opening of 165 μm , wire diameter of 0.05 mm and emulsion thickness of 25 μm . A picture of the final sensor is shown in Fig. 3.

B. Measurement procedure

At first, the capacitance is measured from each of the samples, from both sides to get reference values. A layer of lint (approximately 1 mm) is then added on the front side of the filter. The lint is the normal residue found from a dryer filter, after drying clothes. The capacitance is then re-measured, and the observed difference is analyzed. The difference will change when lint/dirt starts to accumulate on the other side of the filter. For the measurements, Hewlett

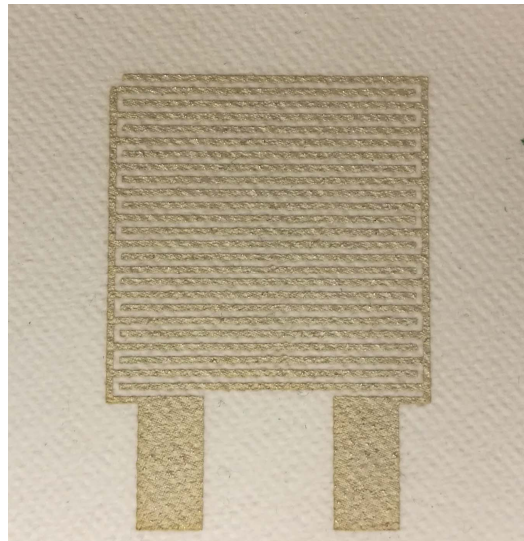

Fig. 3. A picture of the capacitive sensor (front side) screen printed on a HEPA filter with silver paste.

Packard 4285A Precision LCR-meter is used with a four-point measurement principle. The high voltage and high current were connected to one contact of the sensor, and the low voltage and low current were connected to the other contact of the sensor. The manually placed contacts are firm copper clips to ensure a good contact with the sensor. The frequency of 100 kHz and voltage of 1 V were used in these measurements.

The following measurement steps were used for each sample: 1) The sample is measured on both sides; 2) The lint is pressed flat on the front side by hand, so that it covers all of the printed area except the contacts; 3) The sample is measured on both sides; 4) The lint is removed from the sample without detaching the sample from the LCR-meter; 5) The new lint-free values for the both sides are measured. This measurement procedure is repeated for seven presumably similar sensor samples and the obtained results are shown in Table I.

IV. RESULTS

The measured and calculated values derived from them are shown in Table I, and Fig. 4 shows the graphic presentation of the results. The last column in the table reveals the significant information; when the lint is placed onto the sensor, the difference between capacitances changes considerably, and when the lint is removed the capacitance returns to the initial value. This is clearly visible in the Fig. 4; the lint causes different amount of change for each sample, from 14 % to 45 %, while the difference of the reference state (no lint) and the final state (lint off) is minimum.

The following calculations were used for the results:

The difference in farads:

$$C_F - C_B = C_D \quad (1)$$

The difference in percentage:

$$\frac{C_D * 100}{C_B} = D \quad (2)$$

The change in the difference, in farads:

$$C_{D(no\ lint)} - C_{D(no\ lint)} = C_{C(no\ lint)} \quad (3)$$

$$C_{D(no\ lint)} - C_{D(lint)} = C_{C(lint)} \quad (4)$$

$$C_{D(no\ lint)} - C_{D(lint\ off)} = C_{C(lint\ off)} \quad (5)$$

The change in the difference, in percentage:

$$\frac{C_C * 100}{C_D} = D_C \quad (6)$$

where C_F is the capacitance on the front side, C_B is the capacitance on the back side, C_D is the absolute difference between C_F and C_B , D is the difference between C_F and C_B in percentage, C_C is the change in the difference between the reference state (no lint) and the state specified in a subscript and D_C is the change in the difference in percentage. Without a specific subscript, the values in a formula are from the same state.

The difference between the capacitances at the initial stage is insignificant, because only the change in the difference between them is relevant to the work. In addition, the change in the difference shows clearly that the added lint rises the capacitance difference up to 45 %, being a clear indication that the dirtiness condition of the filter can be monitored with the proposed concept. Since the dirt accumulation occurs in an artificial way, which differs from real-life conditions, the

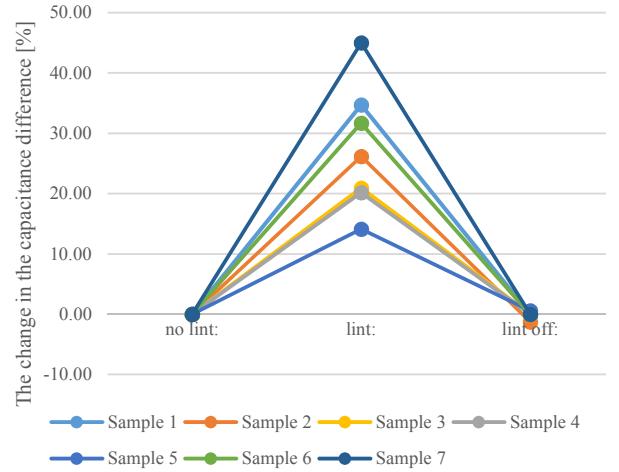

Fig. 4. A graphic presentation of the result. The reference state (no lint) and the lint off-state has a minimum difference while the influence of the added lint is up to 45 %.

magnitude of percentage value is indicative and the sensitivity evaluation of the sensor requires further investigation.

V. DISCUSSION

At the initial stage the capacitances between the front and the back side differs from each other's in spite that they are made the same way. Three possible reasons can be identified. One is the fact, that the filters' front and back sides have a different texture, which has an influence on the printing result (topology, thickness). The second reason is that the substrate surface texture is coarser on the back side, this has some affect to the surface area of the printed pattern and most likely to the permittivity between the electrodes. Among other factors these variables influence the capacitance value. However, this phenomenon is the most unlikely to explain the difference between the samples. Finally, to achieve the wanted

TABLE I. THE MEASURED AND CALCULATED RESULTS

Sample no:	State	Back (C_B) [pF]	Front (C_F) [pF]	Difference (D) [%]	Change in difference (D_C) [%]
1	no lint:	6.19	6.81	10.0	0.0
	lint:	6.25	7.20	15.2	34.7
	lint off:	6.20	6.82	10.0	0.0
2	no lint:	5.94	6.73	13.3	0.0
	lint:	5.98	7.05	17.9	26.2
	lint off:	5.95	6.73	13.1	-1.3
3	no lint:	5.66	6.68	18.0	0.0
	lint:	5.70	6.99	22.6	20.9
	lint off:	5.66	6.68	18.0	0.0
4	no lint:	5.65	6.72	18.9	0.0
	lint:	5.69	7.03	23.6	20.2
	lint off:	5.66	6.73	18.9	0.0
5	no lint:	5.01	6.71	33.9	0.0
	lint:	5.01	6.99	39.5	14.1
	lint off:	5.00	6.71	34.2	0.6
6	no lint:	6.02	6.58	9.3	0.0
	lint:	6.06	6.88	13.5	31.7
	lint off:	6.03	6.59	9.3	0.0
7	no lint:	6.13	6.46	5.4	0.0
	lint:	6.17	6.77	9.7	45.0
	lint off:	6.14	6.47	5.4	0.0

alignment, the patterns are hand printed, which might bring small variance to the uniformity of the samples. Especially the sample 5 has a significantly smaller initial capacitance on the back side sensor. A visual investigation implies that the lower initial value is due to a substrate texture, which seems coarser on the back side of the sample 5 than with other samples.

The reported dirt accumulation analysis relies on the assumption that the surrounding environment has no sudden and large changes in temperature or humidity during the measurement. The filter allows humidity and heat to pass through, but because of the density of the filter structure, the equilibrium condition over the filter structure is not obtained immediately in a case of rapid change. However, in the case of small, and/or slow changes of those environmental parameters, the effect is not significant. To determine the allowed changes in the environment, further studied should be made.

Due to the lack of a controllable system to make actual dirt accumulation during the measurement, the sensor response is not perfectly identical with the real use conditions in which the filter will trap the particles inside the filter. Due to the nature of HEPA filter, only few particles will penetrate the filter completely, but most of them will stay on or close to the front surface. Therefore, it is highly probable, that the change in the capacitance would be even greater in real life. The influence of particle trapping on the capacitive response of the sensor needs more detailed investigation, being also valuable from a sensor design optimization point of view.

It should be noted that as the capacitance is measured from one side, the measured value includes, not only the capacitance of that sensor, but also the capacitance formed between the two sensors. Therefore, the capacitance value measured from the back side rises insignificantly, as the capacitance rises on the front side due to the lint. This aspect must be considered when determining the threshold condition defining the need for the replacement of a dirty filter. The limit of a tolerable amount of dirt on the filter has not been determined in this study but should be tested in a large-scale environment suited for a specific application.

For a further study, the sensor layout shall be investigated to optimize the response and sensitivity. It might also be useful to test whether different sized sensor pairs (one pair with sensors of one size) react differently to variants in the surrounding environment. Could the influence of temperature and humidity be excluded from the measurement results? Does a sensor with different dimensions have different sensitivity to temperature for example? On the other hand, the influence of the sensing element on the airflow should be minimized to make sure that the filter is working as efficiently as possible. From that perspective, size and width of the capacitance element should be minimized.

HEPA and HEPA-type filters are commonly used in areas where clean air is needed. Today people spend most of their time indoors and therefore clean breathing air inside is important. Modern houses have mechanical ventilation, which requires regular filter replacement. The common recommendation for the replacement is twice a year, but it strongly depends on the living conditions and surrounding environment. Close to busy roads or high-pollen trees, the replacement cycle can be much shorter. The filter replacement is under the responsibility of the occupant, which means that most will follow the guidelines, but cannot tell if it is enough

for their house. Therefore, the proposed sensor concept could assist the occupant by informing the need for replacement. In Finnish households, the air filters of class F7 are the most common ones. They filter at least 80 % of the particles of the size 0.4 μm or grater. Although the concept utilized a HEPA filter, it can be applied to any filter with fine enough surface texture.

Another common household appliance with an air filter is a vacuum cleaner. The filter is used to prevent the particles from re-entering the breathing air from the vacuum. When the filter gets too dirty, it reduces the suction and without the cooling air, the vacuum heats up unnecessarily much. Robot vacuums are self-operating cleaners. They could also be self-monitoring by sensing the state of the filter. Between cleaning, they are stationed at a dock for charging. While charging the vacuum, the dock could check the state of the filter and when necessary, let the user know when it is time to change the filter. By changing the filter on time, it reduces the wearing of the electronics as it is allowed to cool down as designed. In addition, the breathing air stays cleaner, as the clean filter does not allow the particles re-enter the room and the suction is at a correct level.

VI. CONCLUSION

A double-sided capacitive sensor is fabricated on a HEPA filter. It is demonstrated to detect lint accumulation on one side of the filter. From this, it is concluded that the presented structure can help monitor the level of purity of a filter. Filter status monitoring improves the energy efficiency of the air cleaning systems and reduces the need for unnecessary maintenance. Silk screen printing is an excellent method of fabricating these sensors.

REFERENCES

- [1] APC Filtration Inc., "5 Uses for HEPA filters in healthcare and medical environments," <https://www.apcfilters.com/5-uses-for-hepa-filters-in-healthcare-and-medical-environments/>, Retrieved on Oct. 24, 2019.
- [2] Graver Technologies, "HEPA filters application," <https://www.gravertech.com/markets-applications/industrial/hepa-filters-application/>, Retrieved on Oct. 24, 2019.
- [3] Shanghai Hefil Purifying Equipment Manufacturing Co, "Wide applications of HEPA filters," <http://www.hefilter.com/Industry-News/Wide-Applications-of-HEPA-filters.shtml>, Retrieved on Oct. 24, 2019.
- [4] European Committee for Standardization, "European Standard, EN 1822-1:2009, High efficiency air filters (EPA, HEPA and ULPA)," 2009.
- [5] American Society of Mechanical Engineers, "ASME AG-1a-2004, Addenda to ASME AG-1-2003 Code on nuclear air and gas treatment," 2004.
- [6] P.C. Raynor and T.M. Peters, "Chapter 7 - Controlling Nanoparticle Exposures," in *Assessing Nanoparticle Risks to Human Health*, William Andrew, 2016, pp. 153-177.
- [7] M. Wilcox, R. Kurz and K. Brun, "Technology review of modern gas turbine inlet filtration systems," *Int. J. Rotating Mach.*, vol. 2012, 2012, ID 128134.
- [8] M.W. First, "HEPA filters," *Appl. Biosaf.*, vol. 3, 1998, pp. 33-42.
- [9] N. White, "Thick Film Processing," in *Springer Handbook of Electronic and Photonic Materials*, Spinger International Publishing AG, 2017, pp. 708-709.
- [10] L. Jian, "Screen printing," in *Printed electronics: Materials, Technologies and Applications*, Wiley, 2016, pp. 116-118.
- [11] J. Izdebska, "Printed electronics," in *Printing on Polymers*, William Andrew, 2016, pp. 382-384.
- [12] Y. Ilgu, *Printed Electronics - Current Trends and Applications*, InTech, 2016.

- [13] D. Gregor-Svetec, "Printed Electronics," in *Nanomaterials for Food Packaging*, Elsevier, 2018, pp. 217-221.
- [14] K. Keränen, P. Korhonen, J. Rekilä, O. Tapaninen, T. Happonen, P. Makkonen and K. Rönkä, "Roll-to-roll printed and assembled large area LED lighting element," *Int. J. Adv. Manuf. Technol.*, vol. 81, pp. 529-536, May 10, 2015.
- [15] R.R. Søndergaard, M. Hösel and F.C. Krebs, "Roll-to-Roll fabrication of large area functional organic materials," *J. Polym. Sci. B Polym. Phys.*, vol. 51, pp. 16-34, January 1, 2013.
- [16] J. Voutilainen, T. Happonen, J. Häkkinen and T. Fabritius, "All silk-screen printed polymer-based remotely readable temperature sensor," *IEEE Sensors J.*, vol. 15, pp. 723-733, Aug 21, 2014.
- [17] J. Voutilainen, T. Happonen, J. Häkkinen and T. Fabritius, "Screen-printed remotely readable environmental sensor pair," *J. Sen.*, vol. 16, pp. 3523-3531, 2016.