

Is individual- and school-level teacher burnout reduced by proactive strategies?

Janne Pietarinen, Kirsi Pyhältö, Kaisa Haverinen, Esko Leskinen & Tiina Soini

To cite this article: Janne Pietarinen, Kirsi Pyhältö, Kaisa Haverinen, Esko Leskinen & Tiina Soini (2021) Is individual- and school-level teacher burnout reduced by proactive strategies?, *International Journal of School & Educational Psychology*, 9:4, 340-355, DOI: [10.1080/21683603.2021.1942344](https://doi.org/10.1080/21683603.2021.1942344)

To link to this article: <https://doi.org/10.1080/21683603.2021.1942344>



© 2021 The Author(s). Published with license by Taylor & Francis Group, LLC.



Published online: 02 Jul 2021.



Submit your article to this journal [↗](#)



Article views: 1290



View related articles [↗](#)



View Crossmark data [↗](#)

Is individual- and school-level teacher burnout reduced by proactive strategies?

Janne Pietarinen^a, Kirsi Pyhältö^{b,c,d}, Kaisa Haverinen^a, Esko Leskinen^e, and Tiina Soini^f 

^aSchool of Applied Educational Science and Teacher Education, University of Eastern Finland, Joensuu, Finland; ^bFaculty of Educational Sciences, Centre for University Teaching and Learning, University of Helsinki, Helsinki, Finland; ^cFaculty of Education, University of Oulu, Oulu, Finland; ^dDepartment of Curriculum Studies, University of Stellenbosch, Stellenbosch, South Africa; ^eDepartment of Mathematics and Statistics, University of Jyväskylä, Jyväskylä, Finland; ^fFaculty of Education and Culture, Tampere University, Tampere, Finland

ABSTRACT

There is provisional evidence that burnout may be contagious within professional communities via the crossover effect, referring to an inter-individual transmission of stress or strain. However, our understanding of effective means for tackling stressors is scarce. We tested a two-level path model to explore the interrelation between teachers' proactive self- and co-regulative strategies and experienced burnout. The study sample comprised 1531 Finnish in-service teachers from 75 schools. The results showed that burnout symptoms varied both between individual teachers and between professional communities. Self- and co-regulative strategies serve partly different functions in regulating teacher burnout symptoms.

KEYWORDS

Teacher burnout; proactive strategies; self-regulation; co-regulation; multilevel modeling

Introduction

Teacher burnout has become a global epidemic. In comparison with other academic, client-related professions, teachers have been found to surpass average stress levels. In particular, they have been found to experience high levels of exhaustion while experiencing lower levels of cynicism and inadequacy, constituting the three core dimensions of burnout (Pietarinen, Pyhältö, Soini, & Salmela-Aro, 2013a, 2013b). Depending on the country of origin and grade taught, between five and 29% of teachers suggested they had suffered from burnout at some stage of their teaching career (see meta-analysis by García-Carmona et al., 2019; Schaarschmidt & Fischer, 2001). Burnout has serious consequences both for the individual teacher, such as depression, insomnia, and health issues (Shin et al., 2013), and for the school community, including early retirement, career turnover, and reduced teaching quality (Dupriez et al., 2016; Goddard & Goddard, 2006; Klusmann et al., 2008).

Previous research has identified several antecedents of teacher burnout. For instance, high workload, poor sense of community, and destructive friction in social interactions, both with pupils and with colleagues, have been found to increase teachers' risk of experiencing burnout (Aloe et al., 2014; Cano-García et al., 2005; Dorman, 2003; Gavish & Friedman, 2010; Leung & Lee, 2006). In turn, autonomy, supervisory support,

and opportunities to receive constructive feedback and professional recognition have been found to reduce the risk (e.g., Beltman et al., 2011; Kokkinos, 2007; Peeters & Rutte, 2005; Stoeber & Rennert, 2008). The pupils' socio-economic status (SES) has been shown to affect the quality and the quantity of stressors teachers are exposed to in their work (Klusmann et al., 2008). For instance, teaching at schools in low SES neighborhoods calls for more investment in creating a supportive social environment for students (e.g., behave fairly in critical situations, take time to talk about interpersonal problems, and show patience with students' misbehavior), potentially resulting in a more stressful work environment for these teachers compared to those teaching at schools in high SES neighborhoods (Bottiani et al., 2019).

Still, our understanding is limited regarding effective means that enable teachers and professional communities to manage the stressors themselves before development of full-blown burnout. Even less is known about how to proactively buffer teacher burnout. Therefore, the aim of this study is to bridge the gap in the literature by exploring proactive strategies in buffering teacher burnout both at the individual and the school community level. In addition, the impact of a neighborhood's SES and grades taught will be explored at the school level to develop proactive strategies for preventing burnout (i.e., within the professional communities).

Teacher burnout

Teacher burnout is a serious occupational hazard resulting from extensive and prolonged work stress (Foley & Murphy, 2015; Holland, 1982; see also seminal work on burnout in Freudenberger, 1974; Maslach & Jackson, 1981). It has three distinctive symptoms: *exhaustion* that is characterized by a lack of emotional energy and a feeling of being strained and tired at work; *cynicism* consisting of detachment from work, in general, and particularly from colleagues, parents or even pupils, and a sense of professional *inadequacy* consisting of a reduced sense of personal accomplishments at work, typically with regard to the teaching-learning that is at the core of a teacher's work (Brouwers & Tomic, 2000; Hakanen et al., 2006; Maslach et al., 2001; meta-analysis by Montgomery & Rupp, 2005; Schaufeli & Buunk, 2003).

Social relationships play a major role in teacher burnout (Gavish & Friedman, 2010; Milfont et al., 2008; Santavirta et al., 2007; Sharplin et al., 2011). For instance, a poor sense of community and destructive friction in social interactions, with either pupils or colleagues, increase the risk of teacher burnout (Aloe et al., 2014; Cano-García et al., 2005; Dorman, 2003; Gavish & Friedman, 2010; Leung & Lee, 2006). We recently showed that destructive friction and problematic encounters with pupils typically result in a sense of professional inadequacy among teachers, while destructive friction within the professional community often contributes to experienced cynicism (Pyhältö et al., 2011; Pietarinen et al., 2013a, 2013b). Yet, the complexity and dynamics of the social aspects of the work environments provided by the school have often been neglected in studies on burnout among teachers (Devos et al., 2012; Parker et al., 2012). Accordingly, a better understanding of teacher burnout across work environments needs to be attained in order to take effective actions in preventing burnout at schools. To be able to capture the socially embedded nature of teaching, the socio-contextual measures of teacher burnout, such as primary sources that increase feelings of inadequacy or cynicism especially in teachers' everyday work, should be used in exploring teacher burnout (Soini et al., 2010).

Variation between individual teachers and professional communities in terms of teachers' burnout experiences have been detected (Bakker & Schaufeli, 2000; Fernet et al., 2012; Klassen & Durksen, 2014; Kokkinos, 2007; Skaalvik & Skaalvik, 2009). Also, the environments in which the school is located vary, for instance, in terms of neighborhood SES, providing difference antecedents for the quantity and the quality of stressful transactions experienced by teachers. For

example, teachers are more frequently challenged by disciplinary problems in low SES areas, which further increases the risk of experiencing strain and exhaustion (Corbin et al., 2019; Geving, 2007; Klusmann et al., 2008). Among low SES school pupils, school engagement and learning outcomes are shown to be lower, while their need for supportive practices is higher (see review by Berkowitz et al., 2017; Kurdi et al., 2018; Smokowski et al., 2014), which may further add to teacher stress, and thus increase exposure to burnout. Teaching in low SES areas is likely to increase the risk of teacher burnout (Vercambre et al., 2009), while teaching in high SES areas is likely to reduce it.

However, the impact of different stressors is highly dependent on strategies individual teachers and teacher communities have developed to manage them. Such strategies are potentially effective in buffering crossover of burnout within the professional community resulting in differences between the teacher communities at risk of burnout. Crossover refers to an inter-individual transmission of stress or strain (Westman et al., 2011; Westman & Etzion, 1995). This can result from our tendency to mimic and synchronize expressions, feelings, and attitudes with those of another individual automatically and consequently, to converge emotionally (Frenzel et al., 2018, 2009; Hatfield et al., 1994; Reindl et al., 2018; Wong et al., 2017). Crossover can also result from the burned out teachers' negative inter-individual behaviors, such as co-rumination, corrupting the quality of interaction in the professional community, and inducing negative experiences among those teachers who have not been involved in the original experiences that led to burnout (see Boren, 2013; Meredith et al., 2020).

There is provisional evidence that crossover may be stronger in the professional communities characterized by high cohesion and social support, such as schools. This is because professional community members get a sense of their colleagues' stressors and corroborate their stress appraisals during frequent and intense interactions. While providing this support, teachers are exposed to the crossover (Westman et al., 2011). Moreover, while trying to understand their strained colleagues, the teachers with no burnout symptoms are likely to tune in to the negative emotions expressed by their colleagues. Yet, there have been a few studies on crossover in the professional communities of schools, and findings from those studies have been inconsistent. For instance, in their seminal study, Westman and Etzion (1999) did not find crossover between teachers and principals, while Bakker and Schaufeli (2000) showed that teachers who were frequently exposed to colleagues suffering from burnout and who talked about work-related problems, and who did not intentionally

focus on developing co-constructed means for dealing with work-related stressors, were more likely to experience burnout themselves.

This implies that crossover of burnout factors resulting in differences between teacher communities at risk of experiencing burnout could be potentially buffered by the use of self- and co-regulative strategies that allow teachers to deal with stressors proactively. Intentional and proactive inter-professional behaviors, such as providing and receiving help from colleagues in problematic situations, enables both drawing on and building collective resources and joint emotion regulation, and hence providing a route for buffering the inter-individual transmission of stress or strain. Such strategies would potentially allow identification, discussion, monitoring, and proactively protecting teachers from work-related stressors.

Proactive strategies in teacher's work

Teachers can use a variety of strategies to deal with stressors faced at work. They can adapt to or ignore the challenges posed by the situation and change the environment and/or manage the emotions caused by it (Arnold et al., 2010; Foley & Murphy, 2015; see also seminal work on coping by Lazarus & Folkman, 1984; Herman et al., 2020). Teachers can also try to deal with future stressors (Howard & Johnson, 2004). To do this, they can utilize *proactive strategies* that aim not only to cope with immediate stressors being faced, but also to buffer potential stressors in advance by building and using resources at hand (Aspinwall & Taylor, 1997; Pietarinen et al., 2013a; Schwarzer & Hallum, 2008; Straud et al., 2015). Characteristic of proactive strategies is that they are active and future-oriented; they are also typically quite generic since they do not tackle a specific stressor faced in a teacher's every-day work (Gan et al., 2007; Greenglass, 2005; Straud et al., 2015). Such strategies can focus on either regulation of one's own behaviors and thoughts, that is, *self-regulation*, or on inter-individual activities, that is, *co-regulation*, or both (Pietarinen et al., 2013a, 2013b). *Proactive self-regulation* entails regulation of one's own behavior, cognition, and emotions such as reducing work pace when needed, while *proactive co-regulation strategies* refers to building and modifying social resources intentionally, such as asking for, providing, and receiving help from colleagues in dealing with a potential stressor (Pietarinen et al., 2013a; Smith & Lev-Ari, 2005; Soini et al., 2010; Väisänen et al., 2018a, 2018b). It has been suggested that such proactive strategies are effective in reducing teacher burnout (Klassen & Durksen, 2014; Pietarinen et al., 2013a) in two ways: firstly, they enable

buffering stressors advanced by building both individual and social resources, and secondly, they enable dealing with immediate stressors more effectively.

Proactive strategies, such as being prepared, staying organized and seeking help when needed, have been shown to be related to reduced levels of stress among primary and lower secondary school teachers (Klassen & Durksen, 2014; Pietarinen et al., 2013a). Use of self- and co-regulative proactive strategies has also been associated with reduced experience of exhaustion and a better work environment fit among in-service teachers (Pietarinen et al., 2013a). In our previous study, the effects of the proactive strategies on the perceived work environment fit was mediated by reduced exhaustion and cynicism toward the teacher community. The use of co-regulative strategies was associated with reduced levels of cynicism toward the teacher community and sense of inadequacy in teacher-pupil interaction, whereas self-regulative strategies were only effective in reducing teacher exhaustion. In our recent study, we showed that proactive strategy use was also associated with reduced risk of pre-service teacher burnout during teacher education, particularly in terms of experienced exhaustion and sense of inadequacy in studying (Väisänen et al., 2018a, 2018b). In turn, a lack of reciprocity in social relationships and support at work has been found to be related to increased levels of experienced burnout among teachers (A. B. Bakker et al., 2000).

The social resources available and the extent to which the teacher community is multi-professional, may impact teachers' abilities to apply and to develop proactive strategies, and further, their experienced burnout. While moving from primary school (i.e., grades 1–6) to lower secondary school (i.e., grades 7–9) or combined primary and lower secondary school (i.e., all grades 1–9), the teacher community becomes professionally more diverse due to the multiple teacher qualifications, professional views, specified tasks and competencies that, for instance, the class-, subject- and special education teachers have adopted.

This increased diversity in terms of professional expertise in the teacher community provides both additional resources and challenges for building teachers' occupational well-being. Although, a multi-professional community potentially provides more extensive resources for proactive strategy use; it also calls for highly sophisticated skills of utilizing such a diverse network of professionals in order to apply proactive co-regulation systematically and successfully, which is not easily realized. There is also tentative evidence that the number of different classes taught is more relevant to exhaustion than the number of teaching

hours, implying that lower secondary school teachers who are typically teaching several different classes and student groups, and hence are more frequently involved in different social contexts, may require more emotional adaptiveness, which may in turn lead to the depletion of emotional resources (Klusmann et al., 2008).

It can be presumed that the more multi-professional a teacher community becomes, proactive strategy use becomes more challenging, hence the risk of experiencing burnout in such communities is greater. However, according to our best knowledge, no studies have yet explored the association between teacher proactive strategy use and burnout at both individual teacher and professional community levels.

Research context

Children in Finland start school at the age of seven after one year of pre-school, and children's guardians are highly trusting of the educational system and services provided by the local school. Students typically attend their neighborhood school. To ensure equal opportunities for all students across the country, there is no ability tracking early on in vocational and academic tracks. All the schools are publicly funded and follow a Finnish national core curriculum. Differences in students' learning outcomes between schools are among the lowest in the world (OECD, 2016). Flexible accountability structures are applied, emphasizing trust in and autonomy of teachers and schools (Aho et al., 2006). This sets high requirements for teacher qualifications. Primary and lower secondary school teachers must have a master's degree in either educational science or another domain, such as mathematics or biology, with compulsory minor studies (35 credits) in educational science. The class teachers hold a master's degree in educational science with a focus on applied educational science or educational psychology. Subject teachers usually have a master's degree in a certain subject with an additional compulsory year of study in educational science. Special education teachers have a master's in educational science, with their main subject being special education (Pietarinen et al., 2013a).

In the Finnish educational system, teachers within a school form a professional community that is encouraged and expected to develop school practices collaboratively based on the core curriculum. However, professional communities and a teacher's work in primary schools and lower secondary schools differ to some extent from those in combined schools, due to the different age groups of students to be taught, and how diverse the professional community is. Subject teachers teach several student groups per day compared with the

class teachers who have most of the lessons per week with the same student group. Also, the proportion of class-, subject-, special education teachers and student counselors differs across the school types and levels. These partly differentiated ways of organizing a teacher's everyday work in the professional community may also produce specific stressors for each school type (e.g., García-Carmona et al., 2019).

Aim of the study

The aim of the study was to gain a better understanding of how to reduce teacher burnout both at the individual and the professional community level. We tested a two-level path model to explore the interrelation between the teachers' proactive strategies (i.e., self- and co-regulation) and the socio-contextual burnout (i.e., exhaustion, cynicism toward the teacher community, and sense of inadequacy in teacher-pupil interaction) they experienced. Drawing on our previous findings suggesting that proactive strategies might provide a way to reduce both pre- and in-service teachers' burnout risk (Pietarinen et al., 2013a; Väisänen et al., 2018a, 2018b), and tentative evidence on the epidemic nature of the teachers' burnout within the professional community (Bakker & Schaufeli, 2000), we tested the following three hypotheses (see Figure 1):

H1: The proactive strategies, including both self-regulative (SELF-REG) and co-regulative (CO-REG) strategies adopted by teachers and shared by professional communities, are related to reduced levels of experienced burnout in terms of exhaustion (EXH), cynicism toward the teacher community (CYN), and sense of inadequacy in teacher-pupil interaction (INAD) both at the individual level (within-level) and the school level (between-level). While the use of self-regulative strategies is expected to relate negatively to the perceived exhaustion, co-regulative strategies are expected to relate negatively to the experienced cynicism toward the teacher community both at the individual and school levels (Fernet et al., 2012; Klassen & Durksen, 2014; Kokkinos, 2007; Pyhältö et al., 2011; Skaalvik & Skaalvik, 2009).

H2: The SES of the school district is negatively related to teachers' reported use of the proactive self-regulative (SELF-REG) and co-regulative (CO-REG) strategies at the school level. That is, the lower SES of the school district increases the demand for developing and utilizing proactive strategies within the professional community in order to cope with stressors set by low SES (Bottiani et al., 2019; Vercambre et al., 2009). Low SES is related to more frequent use of proactive strategies and through this, reduced levels of experienced burnout symptoms EXH,

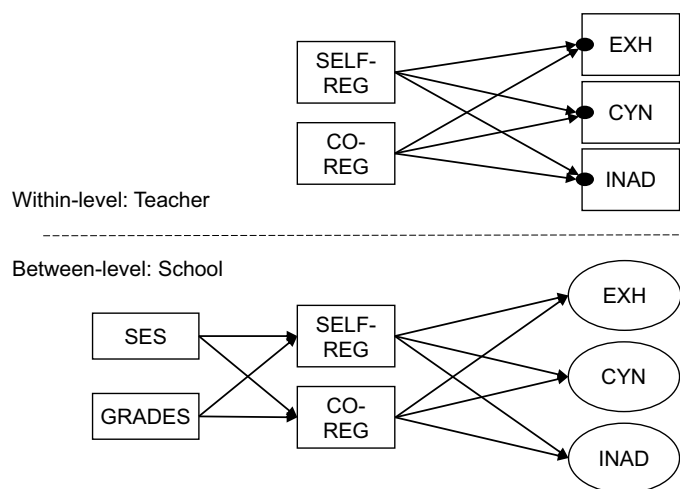

Figure 1. Hypothetical model of teacher burnout and regulative strategies at the teacher and school levels.

CYN, and INAD at the school level (Berkowitz et al., 2017; Kurdi et al., 2018; Smokowski et al., 2014).

H3: The academic level of the school, that is, the grades taught at the school (GRADES), is negatively related to the use of the proactive self-regulative (SELF-REG) and co-regulative (CO-REG) strategies, and positively related with perceived burnout symptoms (EXH, CYN and INAD) at the school level due to the increased complexity of the professional community. That is, proactive regulation is more challenging in multi-professional teacher communities (García-Carmona et al., 2019; Klusmann et al., 2008).

Method

Sampling strategy and participants

We created a two-level research design in order to explore teachers within their professional communities. In addition to studying the individual teacher's experience, the design enabled exploring whether the professional communities (i.e., schools) differed from each other in terms of the reported use of proactive self- and co-regulative strategies regulating burnout symptoms, including the experienced exhaustion, cynicism toward the teacher community and sense of inadequacy in teacher-pupil interactions.

The selection of the schools proceeded in three nested phases. Firstly, six school districts were selected for the sample, presenting variation in terms of the geographical location (both urban/rural) and the size of the network in which the most recent curriculum reform work was carried out (see also Pyhältö et al., 2018). Secondly, based on the

national SES indicator data, requested from Statistics Finland (see also Statistics Finland, 2013), a profile was established for all schools in the districts ($N = 303$) in terms of the SES of the living area. More specifically, we formed the school's SES index based on six socio-economic indicators: *the proportion of adults with a higher education degree, the proportion of adults with pure basic education (i.e., having completed only compulsory education including primary and lower secondary school), the median income of the residents, the median income of the households, the unemployed–employed ratio, and the unemployment per cent in the living area surrounding each school.*

Thirdly, based on the combination of these six SES indicators, a general SES index was calculated for each school. The school's SES index was the average of these SES indicators. Based on this, three-quarters of the schools (>50 students) posited in the upper and lower quarters in terms of the SES index were included in the final sample ($n = 122$). Based on district- and city-level permissions, those schools in the area were contacted and invited to participate in the study. Accordingly, 101 out of 122 schools responded to the initial invitation for whether they were interested in participating in the study. All in all, 75 out of the 122 schools accepted the invitation and participated in the study (i.e., school-level response rate was 61%). The schools in the sample represented the demographic variation of the schools in Finland, that is, they were situated throughout the country and varied in size, location (rural/urban) and school SES (low/high).

The study sample comprised 1531 in-service teachers from 74¹ schools (The academic level of the schools: 49 primary, 9 lower secondary, and 16 combined primary and

¹The teachers' responses to the scales were received from the 74 out of the 75 schools due to a technical paper print survey error (one page was not copied in one school's printed paper surveys).

lower secondary schools). The average size of the teacher community was 20.7 teachers per school (range 3–58 teachers).

The data were collected during field work by the researchers at a common meeting of the teachers on school premises during autumn 2016. Teachers were informed about the study before data collection, and they were given the opportunity to opt out of the study or to fill in the survey anonymously. However, the school was still identified in cases where teachers answered anonymously in order to correctly assign teachers to professional community clusters. The teachers who were absent at the time of the research visit, but willing to participate, were given survey forms to fill in and return envelopes. The ethical principles of the study were discussed with the research participants and detailed information related to data management, data storage and reporting was provided.

The response rates in schools varied between 50 and 100%, with an average of 81%. All respondents had master's degrees, and they were at various stages of their careers (i.e., work experience in the teaching profession: mean 15.5 years, SD = 9.6, range 0–46 years). Most of the respondents were women ($n = 1103$, 76%) and the minority were men ($n = 342$, 24%). The gender distribution corresponds with the national statistics for teachers at Finnish schools: females 77% and males 23% (National Board of Education, 2017).

Measures

We utilized two scales for measuring teachers' a) *proactive strategies* (8 items) and b) *socio-contextual burnout* (9 items) (Pietarinen et al., 2013a, 2013b). The final versions of the scales are shown in Appendix A. The *Proactive Strategy* scale consists of eight items measuring two factors of proactive strategies: a) *self-regulation* (4 items) and b) *co-regulation* (4 items).

The *Socio-contextual Teacher Burnout* scale (drawing on seminal work by Maslach and Jackson's burnout scale (Maslach & Jackson, 1981) and Elo, Leppänen, and Jahkola's single item stress scale (Elo et al., 2003) was utilized in exploring teacher burnout (Pietarinen et al., 2013a, 2013b; Pyhältö et al., 2021). The Socio-contextual teacher burnout scale measured three factors: a) *exhaustion* (3 items), b) *cynicism toward the teacher community* (3 items), and c) *sense of inadequacy in teacher-pupil interaction* (3 items). All items were rated on a 7-point Likert scale ranging from 1 (completely disagree) to 7 (completely agree), excluding the stress item that was rated on a 10-point scale.

Two school-level variables were utilized. *Grades* indicated the school type and academic level of the school,

i.e., the grades that were taught in that school: 1 = primary school (grades 1–6; $n = 49$), 2 = lower secondary school (grades 7–9, $n = 9$), 3 = combined primary and lower secondary school ($n = 16$). The school's SES indicated the socio-economic characteristics of the living area surrounding each school (see sampling strategy): 0 = low ($n = 36$), 1 = high ($n = 38$). The SES and GRADES variables have variance, especially at the school level as the values in these variables are the same for all individual teachers within a certain school.

Statistical analysis

We first conducted a *missing data analysis* using Little's MCAR test (Little, 1988). Altogether, 1516 teachers (97% of the total sample size 1556) had responded to all the items included in the Proactive Strategy and Socio-contextual Teacher Burnout scales used in this study. The proportion of missing values was small: the univariate percentage ranged from 1.7 to 2.5. Little's MCAR test showed that data were missing completely at random ($\chi^2(13) = 21.55$, $p = .06$). We utilized the full-information maximum likelihood procedure in further analyses.

Due to the two-level research design and the nested structure of the data, the *Intraclass correlation coefficient* (ICC) and the *design effect* (Deff) were calculated in order to make the decision about appropriate statistical analysis for the clustered data. ICC describes the proportion of variance on the between-level (i.e., school-level), and design effect approximates the effect of clustered design by weighting the variance proportions with the average cluster size (see e.g., Snijders & Bosker, 2012, pp. 17–23). Because the study focuses especially on analyzing between-level effects (Huang, 2018), the following cutoff criteria were used for determining the effect of clustered design: ICC above 5% (Heck & Thomas, 2008) and Deff over 2 (see Lai & Kwok, 2015, for a lower threshold of Deff = 1.1). Based on the ICC (range 2–15%) and Deff (range 1.29–3.91) statistics, two-level structural equation modeling (SEM) was applied to account for the clustered structure of the data. The school-level variation was notable in the adopted co-regulative strategies and perceived cynicism in the professional community (see Table 1).

Evaluating model fit

The model fit was evaluated by several model fit indices: Chi-squared test of model fit, Root Mean Squared Error of Approximation (RMSEA), Comparative Fit Index (CFI), Tucker-Lewis Index (TLI) and Standardized Root Mean Squared Residual (SRMR). The model fit was evaluated against the following cutoff criteria:

Table 1. Descriptive statistics of the scales on teacher burnout and proactive strategies, and correlations on within-school and between-school levels.

Scale	N	1. EXH	2. CYN	3. INAD	4. SELF-REG	5. CO-REG
1. Exhaustion	1530		.312	.458	-.470	-.333
2. Cynicism	1517	.239		.331	-.173	-.474
3. Inadequacy	1519	.651	.481		-.316	-.172
4. Self-regulation	1521	-.900	-.081	-.652		.350
5. Co-regulation	1520	-.206	-.880	-.571	.044	
No of items		3	3	3	4	4
Min-Max		1.00–8.00	1.00–6.67	1.00–7.00	1.00–7.00	1.00–7.00
Mean		3.74	2.83	2.68	4.99	4.17
SD		1.82	1.18	1.17	1.14	1.25
Alpha		.83	.71	.71	.85	.88
ICC		.051	.150	.018 ^a	.015 ^a	.087
Design effect		1.77	3.91	1.35	1.29	2.66

Correlations at the within-level (individual teachers) are above diagonal, correlations at the between-level (schools) are under diagonal. Alpha = Cronbach's alpha coefficient for scale reliability, ICC = intraclass correlation coefficient.

^aNon-significant value at the $p < .05$ level.

a non-significant chi-squared test value, CFI and TLI both above .95, RMSEA below .05 and SRMR below .05 would indicate a good model fit (Hu & Bentler, 1999).

Model building strategy

The hypothesized two-level path model (see Figure 1) was initially estimated by testing the within-level covariance structures between the observed variables, and by forming random intercepts according to the within-level observed variables and similar covariance structures at the between-level. Firstly, the hypothesized model without the school-level covariates (i.e., Grades and SES) was tested. The between-level predictors SELF-REG and CO-REG were grand mean centered. Secondly, the two school-level covariates were included in the model as predictors of each between-level variable (proactive strategies and burnout symptoms). Thirdly, the SEM model was modified in order to achieve a better fit with the data: Residual covariances between burnout symptoms were allowed at the within level but removed from the between level as they, along with other non-significant paths, were deemed unnecessary. Finally, the indirect effects from school-level covariates (Grades and SES) on burnout symptoms were tested.

Descriptive and missing values analyses were conducted using *IBM SPSS Statistics* software (version 25). SEM analysis was performed using the *Mplus* program (version 8.2; Muthén & Muthén, 1998–2017). We used the robust maximum likelihood (MLR) estimator (that produces robust standard errors and chi-square statistics) to handle the slightly non-normally distributed data.

Methodological considerations

The two-level, cross-sectional and self-report study design combined with the two school-level covariates, i.e., SES

indicator and academic level of the school, were used for studying teacher burnout in a novel way. This was done by assuming that the proactive self- and co-regulative strategies enable both drawing on and building collective resources, as well as joint emotion regulation. Together, these provide a route for buffering the inter-individual transmission of stress or strain at the individual and professional community levels (Pietarinen et al., 2013a; Pyhältö et al., 2021; Westman et al., 2011; Westman & Etzion, 1995). The study design was originally developed for analyzing the clustered nature of the data.

The response rate in the study was satisfactory at both the school and individual levels. The nested strategy for selecting a) enough schools around the country and b) all teachers within each school, contributed to the acceptable representativeness of the sample. Based on national statistics (e.g., National Board of Education, 2017), the variation between schools in terms of the location (urban/rural), school type (primary-, lower secondary- or combined school) and composition of the teacher communities (class-, subject- and special education teachers) was acceptable. Also the representativeness of the Finnish teacher population in terms of gender, teacher groups and work experience in the teaching profession was moderately achieved.

The printed paper survey was introduced, described, and collected at each school by a member of the research group. The specified information related to the purpose of the research project, data collection, using 7-point Likert-scales, and accounting for research ethics issues, increased the number of the respondents and raised the quality of the numerical data by decreasing the risk of receiving unfinished questionnaires (i.e., proportion of missing values) and by reducing self-report biases.

The validity and reliability of the scales used in this study and the tested two-level path model were acceptable (Bollen, 1989; Hu & Bentler, 1999). As previous studies

have shown (Pietarinen et al., 2013a; Pyhältö et al., 2021; Väisänen et al., 2018a, 2018b), the developed proactive strategy (SELF-REG $\alpha = .84$; CO-REG $\alpha = .62$) and burnout scales (EXH $\alpha = .81$; CYN $\alpha = .77$; INAD $\alpha = .74$) sufficiently specified the social contexts of experienced cynicism and sense of inadequacy in teachers' work at the individual teacher level. This study, in turn, showed that the burnout scale (EXH $\alpha = .83$; CYN $\alpha = .71$; INAD $\alpha = .71$) and the further developed proactive strategy scale, in terms of co-regulative strategy measurement (SELF-REG $\alpha = .85$; CO-REG $\alpha = .88$), can be used for identifying school-level differences related to proactive regulation of the burnout symptoms in the professional community.

However, even though the construct validity of the scales used is acceptable (Pietarinen et al., 2013a, 2013b; Pyhältö et al., 2021; Väisänen et al., 2018a, 2018b), those have thus far not been validated in other school systems aiming to identify possible school-level variance. The cross-sectional two-level approach does not allow causal assumptions to be made and does not reveal school-level trajectories.

Results

The results showed that the teachers ($N = 1531$) utilized both self- and co-regulative proactive strategies for buffering burnout symptoms in their everyday work (see Table 1). The teachers reported frequent use of *self-regulative strategies*, such as setting limits on their own work [Mean = 4.99]. The use of *co-regulative strategies*, such as sharing and intentionally solving problems causing stress with colleagues, was experienced less often [Mean = 4.17]. Overall, teachers experienced relatively moderate levels of exhaustion [Mean = 3.74], cynicism toward the teacher community [Mean = 2.83], and sense of inadequacy in teacher-pupil interaction [Mean = 2.68]. All the bivariate correlations among the study variables were statistically significant in the expected directions both at the individual and school levels (see Table 1).

The intra-class correlations [$n = 74$; $ICC^{(\min-\max)} = .018-.15$; $Deff^{(\min-\max)} = 1.29-3.91$] indicated that there was slight school-level variation in the exhaustion experienced. Most of the variation in terms of the reported use of the proactive strategies and perceived burnout symptoms were at the individual teacher level. However, more extensive variation between the schools was detected in the use of co-regulative strategies and the cynicism toward the professional community that was experienced (see Table 1). The professional communities' abilities to develop the means to identify, discuss, monitor and proactively buffer the work-related

stressors varied statistically significantly between the schools. This particularly related to the sense of cynicism toward colleagues and co-constructed proactive means for dealing with the stressors that differentiated the professional communities ($n = 74$) (see Table 1).

A two-level path model (see Figure 1) was tested in order to explore interrelations between self- and co-regulated strategies and experienced burnout symptoms both at the individual and school level. The results showed that the specified two-level path model fitted the clustered data well: $\chi^2(15) = 4.23$, $p = 1.00$, CFI = 1.00, TLI = 1.01, RMSEA = .00, SRMR_W = .002, SRMR_B = .075 (see Hu & Bentler, 1999).

The two-level approach to the teachers' proactive strategies and burnout

The results confirmed that the reported use of self-regulative strategies, e.g., adjusting your own work pace, was negatively related to experienced exhaustion ($\beta_W = -.40$) and sense of inadequacy in teacher-pupil interaction ($\beta_W = -.29$) at the individual teacher level, but was a much stronger determinant for regulating exhaustion ($\beta_B = -.88$) and sense of inadequacy in teacher-pupil interaction ($\beta_B = -.66$) at the school level. However, the reported use of self-regulative strategies was not related to reduced levels of experienced cynicism toward the teacher community at the individual teacher or the school level (see Figure 2). The reported use of co-regulative strategy, such as anticipating potentially burdening episodes with colleagues, was negatively related to the cynicism experienced toward the teacher community ($\beta_W = -.48$; $\beta_B = -.87$), and the sense of inadequacy in teacher-pupil interaction ($\beta_W = -.07$; $\beta_B = -.46$) at the individual teacher level, but was particularly negatively related at the school level.

The reported use of co-regulative strategies was negatively related to the exhaustion experienced at the teacher level ($\beta_W = -.19$), but not at the professional community level. The findings showed that the self- and co-regulative strategies adopted in the professional communities played a central role in regulating teacher burnout within them (see Figure 2). The results confirmed H1 by showing that the proactive self-regulative and co-regulative strategies adopted by teachers within the professional community contributed to regulating experienced burnout symptoms. The use of self-regulative strategies seemed to especially block perceived exhaustion, whereas the use of co-regulative strategy was primarily functional in buffering the cynicism experienced toward the teacher community, both at the individual and school levels.

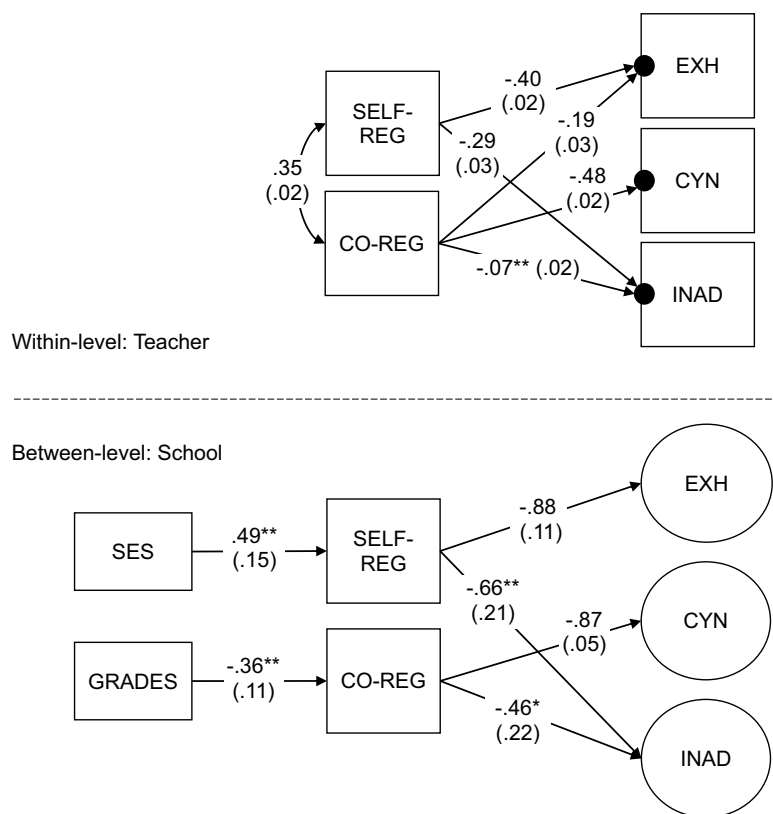

Figure 2. The two-level path model of used proactive strategies and perceived burnout symptoms among Finnish teachers ($N = 1531$) in 74 schools. The model fit: $\chi^2(15) = 4.23$, $p = 1.00$, CFI = 1.00, TLI = 1.01, RMSEA = .00, SRMR_W = .002, SRMR_B = .075. Standardized estimates (standard errors in parentheses) are significant at the $p < .001$ level if not indicated otherwise. ** $p < .01$, * $p < .05$.

School-level covariates: academic level of the school and SES of the school district

The results showed that the SES of the school district (SES) positively explained ($\beta_B = .48$) teachers' perceived use of self-regulative strategies at the school level (see Figure 2). Self-regulation strategies were reported to be applied less frequently in the professional communities situated in the low SES school districts. The SES of the school district did not explain the experienced use of co-regulative strategies or the experienced burnout symptoms (EXH, CYN and INAD) at the school level. However, the indirect paths detected showed that low SES explained the risk of experiencing exhaustion ($\beta_B = -.42$, $p < .01$) and the sense of inadequacy in teacher-pupil interaction ($\beta_B = -.32$, $p < .05$) through the lesser use of self-regulative strategies in the professional community. Accordingly, H2 was not confirmed. Even though the low SES school district probably challenges teachers in terms of applying an intensive, holistic social support for their students, it did not seem to promote the development and more frequent use of co-regulative strategies in

their professional community nor directly trigger the experienced burnout symptoms in the school community.

The school grade, i.e., the school type and grades that were taught at the school (Grades), negatively explained ($\beta_B = -.36$) the reported use of co-regulative strategies. The higher the grade level, that is, the more multi-professional the community, the less frequent use of co-regulative strategies was reported in the professional community. The school grade did not explain the reported use of self-regulative strategies or the burnout symptoms experienced (EXH, CYN, and INAD) at the school level. However, the extended multi-professionalism in the teacher community² had an indirect augmenting relation to the experienced cynicism toward the professional community ($\beta_B = .32$, $p < .01$) through the reduced use of co-regulative strategies. Accordingly, H3 was partly confirmed. The finding may indicate that the more multi-professional the teacher community is, the more challenging it is to use co-regulative strategies as a resource for buffering burnout. Still, the proactive strategies seemed to be significant mediators for regulating the impact of the challenging

²Refers to the combined primary and lower secondary schools that have the largest variation of the class-, subject-, special education teachers and student counselors, and hence, have multiple professional views/competencies as resources in the professional community.

school environment, such as a low SES living area, on the perceived burnout symptoms in the professional community.

Discussion

Findings in light of previous research

The results showed that burnout symptoms varied both between the individual teachers, and between the professional communities (e.g., Fernet et al., 2012; Kokkinos, 2007; Skaalvik & Skaalvik, 2009). Particularly, the perceived cynicism toward colleagues differentiated professional communities. This implies that cynicism may be more easily transmitted within the professional community compared to other burnout symptoms. Since cynicism is characterized by detachment from work and colleagues, it easily corrupts the sense of professional community when other teachers mimic such attitudes. Cynicism transmission is likely to take place via inter-professional behaviors such as co-rumination, thus providing a cognitive route for its spread within the community. Also, a modest difference between the professional communities was detected in the experienced level of exhaustion, indicating the occurrence of inter-individual contagion through emotional toning within the professional community related to exhaustion (e.g., Westman et al., 2011; Westman & Etzion, 1995). The results implied that inter-individual contagion of both cynicism and exhaustion can occur, resulting in differences between the professional communities.

Our results also showed variation between schools in the ability of professional communities to proactively buffer burnout symptoms. The reported use of co-regulative strategies, such as anticipating burdening episodes with colleagues, reduced the cynicism that was experienced toward the teacher community, and the sense of inadequacy in teacher-pupil interaction among individual teachers, but also at the school level. The inadequacy experienced in teacher-pupil interaction varied mainly between individual teachers. However, intentionally building and modifying social resources within the professional community (such as asking for, providing and receiving help from colleagues, i.e., co-regulative strategies), specifically for dealing with problem situations or failures faced when dealing with pupils, seemed to buffer perceived inadequacy at the school level. The reported use of self-regulative strategies, such as adjusting your own work pace, were effective in reducing exhaustion and sense of inadequacy in teacher-pupil interaction, especially at the school level. The findings imply that self- and co-regulative strategies serve partly different functions in reducing teacher burnout symptoms, yet they do provide a potential means for buffering the burnout

at either the individual or the school community level. The self- and co-constructed proactive means for dealing with the stressors partly differentiate the professional communities. This implies that the professional communities had learned how to utilize and build both individual and social resources to regulate future stressors to a different extent. It also implies that such strategies can be learned in the professional community (A. B. Bakker et al., 2000). Thus, proactive strategies may provide a means for buffering the crossover of burnout within the professional community both via shared emotion and behavior regulation. At its best, it may contribute to the spreading of positive emotions and work engagement within the professional community.

The results of this study also suggest that the perceived capacity to adopt proactive self- and co-regulative strategies in the professional community is partly regulated by the SES of the area where the school is located. The results showed that self-regulation strategies were reported to be applied less frequently in the professional communities situated in the low SES school districts. This finding implies that the increased need for social support by the students [and families] in the lower SES school districts may exceed teachers' limits concerning their ability to reduce stress via self-regulative strategies. However, the SES of the school district did not explain the reported use of co-regulative strategies or directly explain the burnout symptoms experienced at the school level (Geving, 2007; Klusmann et al., 2008). The findings suggest that the low SES area schools do not directly contribute to the quantity and the quality of stress experienced by the professional communities. However, the teachers in low SES area schools may have the experience that their professional boundaries have been overextended due to pupils' immediate needs or coping with the stressors faced. This can result in a lack of opportunities to cultivate and utilize proactive strategies in order to be prepared to deal with potential future stressors and therefore reduce burnout.

The extent to which the teacher community is multi-professional, that is, teachers having similar or different disciplinary backgrounds, contributed to the reported use of co-regulative strategies. The social resources available, and especially the structure and diversity of the teacher community, seem to have an impact on the professional communities' abilities to apply and develop the proactive co-regulative strategies. Yet, it was not associated directly with the reported use of self-regulative strategies or experienced burnout. The finding indicates that the more multi-professional the teacher community is, the more challenging it is to apply co-regulative strategies for buffering burnout. This implies that although the multi-professional community provides more extensive resources for proactive strategy

use, it also calls for highly sophisticated skills to utilize such a diverse network of professionals in order to apply proactive co-regulation systematically and successfully, which is highly challenging.

Practical implications

The results of this study have some implications for burnout prevention at schools. They confirmed the previous findings by showing that the reported use of proactive self-regulative and co-regulative strategies buffer the individual teacher's perceived stressors and those strategies have partly differentiated functions for preventing gradually proceeding burnout symptoms (Pyhältö et al., 2011; Pietarinen et al., 2013a). Developing self-regulative strategies seems to be functional, especially in terms of buffering exhaustion and the sense of inadequacy experienced in teacher-pupil interaction. In turn, learning to use co-regulative strategies seems to buffer all burnout symptoms, but especially the perceived cynicism toward the teacher community. Facilitating an individual teacher's capacity to use proactive strategies is necessary, but not enough in terms of preventing the stressors perceived in the professional communities in different neighborhoods (SES) or different schools' academic levels. The novel results further suggest that burnout, especially cynicism, may also be a feature or quality of the community and it may emerge as a product of teacher communities' practices and everyday routines. Results imply a crossover effect; burnout symptoms, especially cynicism may be transmitted in the teacher community. Simultaneously, more frequent use of proactive strategies in terms of regulating teacher burnout can be facilitated and learned, and they too may crossover into the professional community. Dealing with problematic situations with students may act as spaces for either inter-individual transmission of stress or strain, or creating a more proactive collaborative culture. For instance, emotional exhaustion may crossover from teachers to their pupils through emotional contagion due to the affective component of the exhaustion. More specifically, pupils' perceptions of their teachers' emotional states affects their own emotions. This, in turn, seems to be negatively related to pupil's engagement and motivation (e.g., Frenzel et al., 2018, 2009; Wong et al., 2017). However, identifying, creating, and developing practices that facilitate shared planning and collective reflection is a functional means for regulating burnout at the school level. For example, collaborative teaching could offer a means for both pedagogical development to manage the conflicts teachers experience with students (e.g., Corbin et al., 2019) as well as for buffering burnout by encouraging teachers to

take a real interest in others' work and to utilize each other's expertise.

Pupils in more challenging socio-economic areas may have more crucial needs and unpredictable life events affecting schoolwork that lead teachers to reactive work orientation. Teachers and teacher communities in these areas might need support in adopting and maintaining a more proactive orientation in their work. To be able to proactively self-regulate one's work in challenging contexts, teachers need scaffolding and support from the community and encouragement to take time and make efforts to build and use resources of the school's social environment. Buffering burnout with proactive co-regulation, especially in more diverse teacher communities, seems to be a challenge and calls for deliberate building of collaboration skills in the community and recognizing the value of variation in the community as a resource for individual teachers. For example, this means highly intentional acts of leadership that create opportunities for learning to work together.

In summary, proactive strategies are significant mediators for regulating and mastering the school environment. They provide potential tool for enhancing teacher resilience in the professional community, developing contextual support and protective factors in the school district, and buffering teacher burnout (e.g., Beltman et al., 2011). However, the interconnected nature of self- and co-regulation, at both the school and individual levels, should be acknowledged. More precisely, the dynamics of crossover in burnout, as well as in work engagement (A. Bakker et al., 2006), should be better identified in the teacher community. Supporting schools in identifying and regulating the crossover of burnout symptoms provides a novel area for research on teacher burnout. This calls for longitudinal multi-level designs that focus on identifying the stability and/or change of the proactive strategies used and the burnout symptoms collectively experienced in the school community (i.e., among teachers and pupils). A further research aim would be to identify the key determinants that may predict the different developmental paths observed between schools.

Acknowledgments

This work was supported by the Ministry of Education and Culture under Grant [6600567] and the Academy of Finland under Grant [295022].

Data availability statement

The data from this study are not available due to ethical restrictions. Also due to the nature of this empirical research, as well as

participant's individual consent for using data only for scientific purposes within the research group, the gathered survey data cannot be shared publicly and supporting data are not available. Once the research has been completed, the anonymized data will be stored and made available through The Finnish Social Science Data Archive.

Disclosure statement

No potential conflict of interest was reported by the author(s).

Funding

This work was supported by the Academy of Finland under Grant [[295022]]; Ministry of Education and Culture under Grant [[6600567]].

Notes on contributors

Janne Pietarinen *Current Themes of Research*: educational transitions, pupil and teacher learning, and well-being in the context of sustainable school development.

Most Relevant Publications in the field of Psychology of Education: Pietarinen, J., Pyhältö, K., Soini, T. & Salmela-Aro, K. (2013) Reducing teacher burnout: A socio-contextual approach. *Teaching and Teacher Education*, 35, 62–72.

Kirsi Pyhältö *Current Themes of Research*: school development, teachers' professional agency, and teacher well-being.

Most Relevant Publications in the field of Psychology of Education: Pyhältö, K., Pietarinen, J., Haverinen, K., Tikkanen, L. & Soini, T. (in press). Teacher burnout profiles and proactive strategies. *European Journal of Psychology of Education*.

Kaisa Haverinen *Current Themes of Research*: pupils' and teachers' well-being and learning by applying Structural Equation Modeling (SEM) in longitudinal and multilevel designs.

Most Relevant Publications in the field of Psychology of Education: Soini, T., Pietarinen, J., Pyhältö, K., Haverinen, K., Jindal-Snape, D. & Kontu, E. (2019). Special education teachers' experienced burnout and perceived fit with the professional community: A 5-year follow-up study. *British Educational Research Journal*.

Esko Leskinen *Current Themes of Research*: Longitudinal Data Analysis (LDA) and Structural Equation Models (SEM)

Most Relevant Publications in the field of Psychology of Education: Kiuru, N., Nurmi, J.-E., Leskinen, E., Torppa, M., Poikkeus, A.-M., Lerkkanen, M.-K., & Niemi, P. (2015). Elementary school teachers adapt their instructional support according to students' academic skills: A variable and person-oriented approach. *International Journal of Behavioral Development*, 39 (5), 391-401.

Tiina Soini *Current Themes of Research*: educational reforms, school development, teachers' professional agency and well-being, and pupils learning agency.

Most Relevant Publications in the field of Psychology of Education: Soini, T., Pietarinen, J. & Pyhältö, K. (2016). What if teachers learn in the classroom? *Teacher Development*, 20(3).

ORCID

Tiina Soini  <http://orcid.org/0000-0002-0637-8931>

References

- Aho, E., Pitkänen, K., & Sahlberg, P. (2006). *Policy development and reform principles of basic and secondary education in Finland since 1968*. Education Working Paper Series. Number 2. http://siteresources.worldbank.org/EDUCATION/Resources/278200-1099079877269/547664-1099079967208/Education_in_Finland_May06.pdf
- Aloe, A., Shisler, S., Norris, B., Nickerson, A., & Rinker, T. (2014). A multivariate meta-analysis of student misbehavior and teacher burnout. *Educational Research Review*, 12, 30–44. <https://doi.org/10.1016/j.edurev.2014.05.003>
- Arnold, J., Randall, R., Patterson, F., Silvester, J., Robertson, I., Cooper, C., Burnes, B., Swailes, S., Harris, D., Axtell, C., & Den Hartog, D. (2010). *Work psychology: Understanding human behaviour in the workplace* (5th ed.). Pearson.
- Aspinwall, L. G., & Taylor, S. E. (1997). A stitch in time: Self-regulation and proactive coping. *Psychological Bulletin*, 121(3), 417–436. <https://doi.org/10.1037/0033-2909.121.3.417>
- Bakker, A., Emmerik, H. V., & Euwema, M. (2006). Crossover of burnout and engagement in work teams. *Work and Occupations*, 33(4), 464–489. <https://doi.org/10.1177/0730888406291310>
- Bakker, A. B., & Schaufeli, W. B. (2000). Burnout contagion processes among teachers. *Journal of Applied Social Psychology*, 30(11), 2289–2308. <https://doi.org/10.1111/j.1559-1816.2000.tb02437.x>
- Bakker, A. B., Schaufeli, W. B., Demerouti, E., Janssen, P. P. M., Van Der Hulst, R., & Brouwer, J. (2000). Using equity theory to examine the difference between burnout and depression. *Anxiety, Stress & Coping*, 13(3), 247–268. <https://doi.org/10.1080/10615800008549265>
- Beltman, S., Mansfield, C., & Price, A. (2011). Thriving not just surviving: A review of research on teacher resilience. *Educational Research Review*, 6(3), 185–207. <https://doi.org/10.1016/j.edurev.2011.09.001>
- Berkowitz, R., Moore, H., Astor, R. A., & Benbenishty, R. (2017). A research synthesis of the associations between socioeconomic background, inequality, school climate, and academic achievement. *Review of Educational Research*, 87(2), 425–469. <https://doi.org/10.3102/0034654316669821>
- Bollen, K. A. (1989). *Structural Equation with latent variables*. Wiley.
- Boren, J. P. (2013). Co-rumination partially mediates the relationship between social support and emotional exhaustion among graduate students. *Communication Quarterly*, 61(3), 253–267. <https://doi.org/10.1080/01463373.2012.751436>
- Bottiani, J. H., Duran, C. A. K., Pas, E. T., & Bradshaw, C. P. (2019). Teacher stress and burnout in urban middle schools: Associations with job demands, resources, and effective classroom practices. *Journal of School Psychology*, 77, 36–51. <https://doi.org/10.1016/j.jsp.2019.10.002>
- Brouwers, A., & Tomic, W. (2000). A longitudinal study of teacher burnout and perceived self-efficacy in classroom

- management. *Teaching and Teacher Education*, 16(2), 239–253. [https://doi.org/10.1016/S0742-051X\(99\)00057-8](https://doi.org/10.1016/S0742-051X(99)00057-8)
- Cano-García, F. J., Padilla-Muñoz, E. M., & Carrasco-Ortiz, M. Á. (2005). Personality and contextual variables in teacher burnout. *Personality and Individual Differences*, 38(4), 929–940. <https://doi.org/10.1016/j.paid.2004.06.018>
- Corbin, C. M., Alamos, P., Lowenstein, A. E., Downer, J. T., & Brown, J. L. (2019). The role of teacher-student relationships in predicting teachers' personal accomplishment and emotional exhaustion. *Journal of School Psychology*, 77, 1–12. <https://doi.org/10.1016/j.jsp.2019.10.001>
- Devos, C., Dupriez, V., & Paquay, L. (2012). Does the social working environment predict beginning teachers' self-efficacy and feelings of depression? *Teaching and Teacher Education*, 28(2), 206–217. <https://doi.org/10.1016/j.tate.2011.09.008>
- Dorman, J. P. (2003). Cross-national validation of the *What is happening in this class?* (WIHIC) Questionnaire using confirmatory factor analysis. *Learning Environments Research*, 6(3), 231–245. <https://doi.org/10.1023/A:1027355123577>
- Dupriez, V., Delvaux, B., & Lothaire, S. (2016). Teacher shortage and attrition: Why do they leave? *British Educational Research Journal*, 42(1), 21–39. <https://doi.org/10.1002/berj.3193>
- Elo, A.-L., Leppänen, A., & Jahkola, A. (2003). Validity of a single-item measure of stress symptoms. *Scandinavian Journal of Work Environment & Health*, 29(6), 444–451. <https://doi.org/10.5271/sjweh.752>
- Fernet, C., Guay, F., Senécal, C., & Austin, S. (2012). Predicting intra individual changes in teacher burnout: The role of perceived school environment and motivational factors. *Teaching and Teacher Education*, 28(4), 514–525. <https://doi.org/10.1016/j.tate.2011.11.013>
- Foley, C., & Murphy, M. (2015). Burnout in Irish teachers: Investigating the role of individual differences, work environment and coping factors. *Teaching and Teacher Education*, 50, 46–55. <https://doi.org/10.1016/j.tate.2015.05.001>
- Frenzel, A. C., Becker-Kurz, B., Pekrun, R., Goetz, T., & Lüdtke, O. (2018). Transmission in the classroom revisited: A reciprocal effects model of teacher and student enjoyment. *Journal of Educational Psychology*, 110(5), 628–639. <https://doi.org/10.1037/edu0000228>
- Frenzel, A. C., Goetz, T., Lüdtke, O., Pekrun, R., & Sutton, R. E. (2009). Emotional transmission in the classroom: Exploring the relationship between teacher and student enjoyment. *Journal of Educational Psychology*, 101(3), 705–716. <https://doi.org/10.1037/a0014695>
- Freudenberger, H. (1974). Staff burnout. *Journal of Social Issues*, 30(1), 159–165. <https://doi.org/10.1111/j.1540-4560.1974.tb00706.x>
- Gan, Y., Yang, M., Zhou, Y., & Zhang, Y. (2007). The two-factor structure of future-oriented coping and its' mediating role in student engagement. *Personality and Individual Differences*, 43(4), 851–863. <https://doi.org/10.1016/j.paid.2007.02.009>
- García-Carmona, M., Marín, M. D., & Aguayo, R. (2019). Burnout syndrome in secondary school teachers: A systematic review and meta-analysis. *Social Psychology of Education*, 22(1), 189–208. <https://doi.org/10.1007/s11218-018-9471-9>
- Gavish, B., & Friedman, I. (2010). Novice teachers' experience of teaching: A dynamic aspect of burnout. *Social Psychology of Education*, 13(2), 141–167. <https://doi.org/10.1007/s11218-009-9108-0>
- Geving, A. M. (2007). Identifying the types of student and teacher behaviours associated with teacher stress. *Teaching and Teacher Education*, 23(5), 624–640. <https://doi.org/10.1016/j.tate.2007.02.006>
- Goddard, R., & Goddard, M. (2006). Beginning teacher burnout in Queensland schools: Associations with serious intentions to leave. *The Australian Educational Researcher*, 33(2), 61–76. <https://doi.org/10.1007/BF03216834>
- Greenglass, E. R. (2005). Proactive coping, resources and burnout: Implications for occupational stress. In A.-S. G. Antoniou & C. L. Cooper (Eds.), *New horizons in management. Research companion to organizational health psychology* (pp. 503–515). Edward Elgar Publishing.
- Hakanen, J. J., Bakker, A. B., & Schaufeli, W. B. (2006). Burnout and work engagement among teachers. *Journal of School Psychology*, 43(6), 495–513. <https://doi.org/10.1016/j.jsp.2005.11.001>
- Hatfield, E., Cacioppo, J., & Rapson, R. L. (1994). *Emotional contagion*. Cambridge University Press.
- Heck, R. H., & Thomas, S. L. (2008). *An introduction to multi-level modeling techniques* (2nd ed.). Routledge.
- Herman, K. C., Prewett, S. L., Eddy, C. L., Savala, A., & Reinke, W. M. (2020). Profiles of middle school teacher stress and coping: Concurrent and prospective correlates. *Journal of School Psychology*, 78, 54–68. <https://doi.org/10.1016/j.jsp.2019.11.003>
- Holland, R. P. (1982). Special educator burnout. *Educational Horizons*, 60(2), 58–64. <https://www.jstor.org/stable/42924477>
- Howard, S., & Johnson, B. (2004). Resilient teachers: Resisting stress and burnout. *Social Psychology of Education*, 7(4), 399–420. <https://doi.org/10.1007/s11218-004-0975-0>
- Hu, L.-T., & Bentler, P. M. (1999). Cutoff criteria for fit indexes in covariance structure analysis: Conventional criteria versus new alternatives. *Structural Equation Modeling*, 6(1), 1–55. <https://doi.org/10.1080/10705519909540118>
- Huang, F. L. (2018). Multilevel modeling myths. *School Psychology Quarterly*, 33(3), 492–499. <https://doi.org/10.1037/spq0000272>
- Klassen, R., & Durksen, T. (2014). Weekly self-efficacy and work stress of pre-service teachers during the final teaching practicum: A mixed methods study. *Learning and Instruction*, 33, 158–169. <https://doi.org/10.1016/j.learninstruc.2014.05.003>
- Klusmann, U., Kunter, M., Trautwein, U., Lüdtke, O., & Baumert, J. (2008). Teachers' occupational well-being and quality of instruction: The important role of self-regulatory patterns. *Journal of Educational Psychology*, 100(3), 702–715. <https://doi.org/10.1037/0022-0663.100.3.702>
- Kokkinos, C. M. (2007). Job stressors, personality and burnout in primary school teachers. *British Journal of Educational Psychology*, 77(1), 229–243. <https://doi.org/10.1348/000709905X90344>
- Kurdi, V., Archambault, I., Brière, F. N., & Turgeon, L. (2018). Need-supportive teaching practices and student-perceived need fulfillment in low socioeconomic status elementary schools: The moderating effect of anxiety and academic achievement. *Learning and Individual Differences*, 65, 218–229. <https://doi.org/10.1016/j.lindif.2018.06.002>
- Lai, M. H. C., & Kwok, O. (2015). Examining the rule of thumb of not using multilevel modeling: The “design effect smaller than two” rule. *The Journal of Experimental*

- Education*, 83(3), 423–438. <https://doi.org/10.1080/00220973.2014.907229>
- Lazarus, R., & Folkman, S. (1984). *Stress, appraisal, and coping*. Springer.
- Leung, D. Y. P., & Lee, W. W. S. (2006). Predicting intention to quit among Chinese teachers: Differential predictability of the component of burnout. *Anxiety, Stress, & Coping*, 19(2), 129–141. <https://doi.org/10.1080/10615800600565476>
- Little, R. J. A. (1988). A test of missingness completely at random for multivariate data with missing values. *Journal of the American Statistical Association*, 83(404), 1198–1202. <https://doi.org/10.1080/01621459.1988.10478722>
- Maslach, C., & Jackson, S. (1981). The measurement of experienced burnout. *Journal of Organizational Behavior*, 2(2), 99–113. <https://doi.org/10.1002/job.4030020205>
- Maslach, C., Schaufeli, W. B., & Leiter, M. P. (2001). Job burnout. *Annual Review of Psychology*, 52(1), 397–422. <https://doi.org/10.1146/annurev.psych.52.1.397>
- Meredith, C., Schaufeli, W., Struyve, C., Vandecandelaere, M., Gielen, S., & Kyndt, E. (2020). ‘Burnout contagion’ among teachers: A social network approach. *Journal of Occupational and Organizational Psychology* 93, 328–352. <https://doi.org/10.1111/joop.12296>
- Milfont, T. L., Denny, S., Ameratunga, S., Robinson, E., & Merry, S. (2008). Burnout and wellbeing: Testing the Copenhagen burnout inventory in New Zealand teachers. *Social Indicators Research*, 89(1), 169–177. <https://doi.org/10.1007/s11205-007-9229-9>
- Montgomery, C., & Rupp, A. A. (2005). A meta-analysis for exploring the diverse causes and effects of stress in teachers. *Canadian Journal of Education/Revue Canadienne De L’éducation*, 28(3), 458–486. <https://doi.org/10.2307/4126479>
- Muthén, L. K., & Muthén, B. O. (1998–2017). *Mplus user’s guide* (8th ed.). Muthén & Muthén.
- National Board of Education. (2017). *Opettajat Suomessa [Teachers and principals in Finland 2016]*. Retrieved May 28, 2018 from https://www.oph.fi/julkaisut/2017/opettajat_ja_rehtorit-suomessa_2016
- OECD. (2016). *PISA 2015 results (volume I). Excellence and equity in education*.
- Parker, P. D., Martin, A. J., Colmar, S., & Liem, G. A. D. (2012). Teachers’ workplace well-being: Exploring a process model of goal orientation, coping behavior, engagement, and burnout. *Teaching and Teacher Education*, 28(4), 503–513. <https://doi.org/10.1016/j.tate.2012.01.001>
- Peeters, M. A. G., & Rutte, C. (2005). Time management behavior as a moderator for the job demand-control interaction. *Journal of Occupational Health Psychology*, 10(1), 64–75. <https://doi.org/10.1037/1076-8998.10.1.64>
- Pietarinen, J., Pyhältö, K., Soini, T., & Salmela-Aro, K. (2013a). Reducing teacher burnout: A socio-contextual approach. *Teaching and Teacher Education*, 35, 62–72. <https://doi.org/10.1016/j.tate.2013.05.003>
- Pietarinen, J., Pyhältö, K., Soini, T., & Salmela-Aro, K. (2013b). Validity and reliability of the Socio-contextual Teacher Burnout Inventory (STBI). *Psychology*, 4(1), 73–82. <https://doi.org/10.4236/psych.2013.41010>
- Pyhältö, K., Pietarinen, J., Haverinen, K., Tikkanen, L., & Soini, T. (2021). Teacher burnout profiles and proactive strategies. *European Journal of Psychology of Education*, 36(1), 219–242. <https://doi.org/10.1007/s10212-020-00465-6>
- Pyhältö, K., Pietarinen, J., & Salmela-Aro, K. (2011). Teacher - working environment fit as a framework for burnout experienced by Finnish teachers. *Teaching and Teacher Education*, 27(7), 1101–1110. <https://doi.org/10.1016/j.tate.2011.05.006>
- Pyhältö, K., Pietarinen, J., & Soini, T. (2018). Dynamic and shared sense-making in large-scale curriculum reform in school districts. *The Curriculum Journal*, 29(2), 181–200. <https://doi.org/10.1080/09585176.2018.1447306>
- Reindl, V., Gerloff, C., Scharke, W., & Konrad, K. (2018). Brain-to-brain synchrony in parent-child dyads and the relationship with emotion regulation revealed by fNIRS-based hyperscanning. *NeuroImage*, 178, 493–502. <https://doi.org/10.1016/j.neuroimage.2018.05.060>
- Santavirta, N., Solovieva, S., & Theorell, T. (2007). The association between job strain and emotional exhaustion in a cohort of 1,028 Finnish teachers. *British Journal of Educational Psychology*, 77(1), 213–228. <https://doi.org/10.1348/000709905X92045>
- Schaarschmidt, U., & Fischer, W. A. (2001). *Bewältigungsmuster im Beruf: Persönlichkeitsunterschiede in der Auseinandersetzung mit der Arbeitsbelastung*. Vandenhoeck & Ruprecht.
- Schaufeli, W. B., & Buunk, B. P. (2003). Burnout: An overview of 25 years of research in theorizing. In M. J. Winnubst & C. L. Cooper (Eds.), *The handbook of work and health psychology* (pp. 383–425). Wiley.
- Schwarzer, R., & Hallum, S. (2008). Perceived teacher self-efficacy as a predictor of job stress and burnout: Mediation analyses. *Applied Psychology*, 57(s1), 152–171. <https://doi.org/10.1111/j.1464-0597.2008.00359.x>
- Sharplin, E., O’Neill, M., & Chapman, A. (2011). Coping strategies for adaptation to new teacher appointments: Intervention for retention. *Teaching and Teacher Education*, 27(1), 136–146. <https://doi.org/10.1016/j.tate.2010.07.010>
- Shin, H., Noh, H., Jang, Y., Park, Y. M., & Lee, S. M. (2013). A longitudinal examination of the relationship between teacher burnout and depression. *Journal of Employment Counseling*, 50(3), 124–137. <https://doi.org/10.1002/j.2161-1920.2013.00031.x>
- Skaalvik, E. M., & Skaalvik, S. (2009). Does school context matter? Relations with teacher burnout and job satisfaction. *Teaching and Teacher Education*, 25(3), 518–524. <https://doi.org/10.1016/j.tate.2008.12.006>
- Smith, K., & Lev-Ari, L. (2005). The place of the practicum in pre-service teacher education: The voice of the students. *Asia-Pacific Journal of Teacher Education*, 33(3), 289–302. <https://doi.org/10.1080/13598660500286333>
- Smokowski, P. R., Guo, S., Rose, R., Evans, C. B., Cotter, K. L., & Bacallao, M. (2014). Multilevel risk factors and developmental assets for internalizing symptoms and self-esteem in disadvantaged adolescents: Modeling longitudinal trajectories from the rural adaptation project. *Development and Psychopathology*, 26(4), 1495–1513. <https://doi.org/10.1017/S0954579414001163>
- Snijders, T. A. B., & Bosker, R. J. (2012). *Multilevel analysis. An introduction to basic and advanced multilevel modeling* (2nd ed.). Sage Publications.
- Soini, T., Pyhältö, K., & Pietarinen, J. (2010). Pedagogical well-being: Reflecting learning and well-being in teachers’ work. *Teaching and Teachers: Theory and*

- Practice*, 16(6), 735–751. <https://doi.org/10.1080/13540602.2010.517690>
- Statistics Finland. (2013). *Municipalities and regional divisions based on municipalities, handbooks 28*.
- Stoeber, J., & Rennert, D. (2008). Perfectionism in school teachers: Relations with stress appraisals, coping styles, and burnout. *Anxiety, Stress, & Coping*, 21(1), 37–53. <https://doi.org/10.1080/10615800701742461>
- Straud, C., McNaughton-Cassill, M., & Fuhrman, R. (2015). The role of the Five Factor Model of personality with proactive coping and preventative coping among college students. *Personality and Individual Differences*, 83, 60–64. <https://doi.org/10.1016/j.paid.2015.03.055>
- Väisänen, S., Pietarinen, J., Pyhältö, K., Toom, A., & Soini, T. (2018a). Student teachers' proactive strategies for avoiding study-related burnout during teacher education. *European Journal of Teacher Education*, 41(3), 301–317. <https://doi.org/10.1080/02619768.2018.1448777>
- Väisänen, S., Pietarinen, J., Pyhältö, K., Toom, A., & Soini, T. (2018b). Student teachers' proactive strategies and experienced learning environment for reducing study-related burnout. *Journal of Education and Learning*, 7(1), 208–222. <https://doi.org/10.5539/jel.v7n1p208>
- Vercambre, M. N., Brosselin, P., Gilbert, F., Nèrière, E., & Kovess-Masfety, V. (2009). Individual and contextual covariates of burnout: A cross-sectional nationwide study of French teachers. *BMC Public Health*, 9(1), 333. <https://doi.org/10.1186/1471-2458-9-333>
- Westman, M., Bakker, A. B., Roziner, I., & Sonnentag, S. (2011). Crossover of job demands and emotional exhaustion within teams: A longitudinal multilevel study. *Anxiety, Stress & Coping*, 24(5), 561–577. <https://doi.org/10.1080/10615806.2011.558191>
- Westman, M., & Etzion, D. (1995). Crossover of stress, strain and resources from one spouse to another. *Journal of Organizational Behavior*, 16(2), 169–181. <https://doi.org/10.1002/job.4030160207>
- Westman, M., & Etzion, D. (1999). The crossover of strain from school principals to teachers and vice versa. *Journal of Occupational Health Psychology*, 4(3), 269–278. <https://doi.org/10.1037/1076-8998.4.3.269>
- Wong, V. W., Ruble, L. A., Yu, Y., & McGrew, J. H. (2017). Too stressed to teach? Teaching quality, student engagement, and IEP outcomes. *Exceptional Children*, 83(4), 412–427. <https://doi.org/10.1177/0014402917690729>

Appendix A. The scales and items of teacher burnout and proactive strategies (translated from Finnish)

Scales and items*

Socio-contextual burnout inventory (STBI)

Exhaustion (EXH) (3 items)

Exh11: Stress means a situation in which a person feels tense, restless, nervous or anxious or is unable to sleep at night because his/her mind is troubled all the time. Do you feel this kind of work-related stress?¹

Exh12: I feel burnt out.

Exh13: With this work pace I don't think I'll make it to the retiring age.

Cynicism toward the teacher community (CYN) (3 items)

Cyn21: I'm disappointed in our teacher community's ways of handling our shared affairs.

Cyn22: In spite of several efforts to develop the working habits of our teacher community, they haven't really changed.

Cyn23: I often feel like an outsider in my work community.

Inadequacy in teacher-pupil interaction (INAD) (3 items)

Inad31: The challenging pupils make me question my abilities as a teacher.

Inad32: I often feel I have failed in my work with pupils.

Inad33: Dealing with problem situations considering my pupils often upsets me.

Proactive strategy scale

Self-regulation (SELF-REG) (4 items)

Stra11: I'm able to control my work pace in the busy school work schedule.

Stra12: I can set limits to my work assignments.

Stra13: I know when it's time for me to adjust my work pace.

Stra14: It's possible to learn to adjust the way you manage your work strain.

Co-regulation (CO-REG) (4 items)

Stra21: We openly discuss matters relating to stress and workload in my professional community.

Stra22: We consider a teacher's ability to cope when planning our work.

Stra23: If it appears that a way of working is burdensome, we stop to think about alternatives.

Stra24: We all work together to find solutions to overly demanding situations.

Note. * The item scale: *completely disagree* – 1 2 3 4 5 6 7 – *completely agree*. ¹Except for the item Exh11 that was measured on a 10-point scale from 1 = *not at all* to 10 = *very much*.